



Town of Mesilla, New Mexico

THE BOARD OF TRUSTEES (BOT) OF THE TOWN OF MESILLA WILL HOLD A REGULAR MEETING AT THE MESILLA TOWN HALL, 2231 AVENIDA DE MESILLA.

MONDAY, JUNE 13, 2022 – 6:00 PM

AGENDA

1. PLEDGE OF ALLEGIANCE
2. ROLL CALL & DETERMINATION OF A QUORUM
3. CHANGES TO THE AGENDA & APPROVAL
4. PUBLIC INPUT – The public is invited to address the Board for up to 3 minutes.
5. APPROVAL OF CONSENT AGENDA: (The Board will be asked to approve by one motion the following items of recurring or routine business. The Consent Agenda is marked with an asterisk *)
 - a) ***BOT MINUTES** - Minutes of Budget Work Session, May 18, 2022
 - b) ***BOT MINUTES** - Minutes of Regular Meeting, May 23, 2022
 - c) ***BOT MINUTES** - Minutes of Special Meeting, May 31, 2022
 - d) * **PZHAC Case #061376**– Pappas Williamson seeking for a summary subdivision a Replat of U.S.R.S. Tract 11A-199 & 11A – 198A within the Town of Mesilla, Dona Ana County, N.M. in Section 25, T.23S R.IE of U.S.R.S. Surveys (2532 Calle De Norte), Zoned: **Historical Residential (HR)**.
 - e) ***PZHAC Case #061384** – 2260 Calle de Santiago submitted by Bill & Janice Cook to install rooftop solar system not visible from the street and AC combine panel and data monitoring unit, production meter and customer generation fusible AC disconnect. Zoned: **Historical Residential (HR)**
 - f) ***PZHAC Case #061385** – 2872 Calle San Albino submitted by Jeffry & Amanda Buras to repaint house exterior a different color current color is white. Zoned: **Historical Residential (HR)**
 - g) ***PZHAC Case #061387** – 2060 Calle de Parian Submitted by Julienne Hadfield to patch, repair and repaint windows and door, no color change. Zoned: **Historical Residential (HR)**
 - h) ***BL #0986** – 1395 Snow Rd. submitted by Eric Madrid of Highcienda Growers for a business license. Zoned: **Rural Farm (RF)**
 - i) ***BL #0987** – 1395 Snow Rd. submitted by Eric Madrid of Highcienda Growers for a Cannabis license. Zoned: **Rural Farm (RF)**
 - j) ***BL #0990** – 2710 Boldt St. submitted by Charles McMahon of Chuck McMahon Consulting LLC for a business license. Zoned: **Historical Residential (HR)**
 - k) ***Sign Permit #061391** – 2101 Calle de Parian submitted by Valerie Segovia for Nambe sale sign, Zoned: **Historical Commercial (HC)**
 - l) ***Sign Permit #061390** – 2011 Avenida de Mesilla submitted by Mickey Balderas of The Bean to update Logo sign design attached in packet. Zoned: **Historical Commercial (HC)**
6. STAFF REPORTS
 - a) Local Government Road Fund Program – Rod McGillivray
 - b) NM Tourism Department Cooperative Agreement – Dorothy Sellers
7. NEW BUSINESS
 - a) **For Approval:** Resolution 2022-05 Local Government Road Fund Program # HW2 L100525 Calle de Cura

- b) **For Approval:** Resolution 2022-06 Match Waiver Local Government Road Fund Program # HW2 L100525 Calle de Cura
- c) **For Approval:** NM Tourism Department Cooperative Agreement
- d) **For Approval:** The hiring of three (3) part-time temporary employees for the Summer Recreation Program
- e) **For Approval:** Renew Cooperative Service Field Agreement for Wildlife/Predator Damage Control

8. BOARD OF TRUSTEE COMMITTEE REPORTS

9. BOARD OF TRUSTEE/STAFF COMMENTS

(Written staff reports included in packet)

10. ADJOURNMENT

NOTICE

If you need an accommodation for a disability to enable you to fully participate in the hearing or meeting, please contact us at 524-3262 at least one week prior to the meeting. The Mayor and Trustees request that all cell phones be turned off or set to vibrate. Members of the audience are requested to step outside the Board Room to respond to or to conduct a phone conversation. A copy of the agenda packet can be found online at www.mesillanm.gov.

Posted 6.10.2022 online and at the following locations: Town Clerk's Office 2231 Avenida de Mesilla, Public Safety Building 2670 Calle de Parian, Mesilla Community Center 2251 Calle de Santiago, Shorty's Food Mart 2290 Avenida de Mesilla, Ristramn Chile Co., 2531 Avenida de Mesilla and the U.S. Post Office 2253 Calle de Parian.



Town of Mesilla, New Mexico

BOARD OF TRUSTEES (BOT)

TOWN OF MESILLA

SPECIAL MEETING

WEDNESDAY, MAY 18, 2022

MINUTES

TRUSTEES: Nora Barraza, Mayor
Stephanie Johnson-Burick, Mayor Pro Tem
Biviana Cadena, Trustee
Veronica Garcia, Trustee
Adrianna Merrick, Trustee

STAFF: Rani Bush, Town Clerk/Treasurer
Kevin Hoban, Fire Chief
Enrique Salas, Marshal
Gloria Maya, Recorder

PUBLIC:

1. PLEDGE OF ALLEGIANCE

Mayor Barraza led the Pledge of Allegiance.

2. ROLL CALL & DETERMINATION OF A QUORUM

Roll Call.

Present: Mayor Barraza, Mayor Pro Tem Johnson-Burick, Trustee Cadena, Trustee Garcia, Trustee Merrick.

3. CHANGES TO THE AGENDA & APPROVAL

Motion: To approve agenda, Moved by Mayor Pro Tem Johnson-Burick, Seconded by Trustee Garcia.

Roll Call Vote: Motion passed (**summary:** Yes =4).

Mayor Pro Tem Johnson-Burick Yes

Trustee Cadena Yes

Trustee Garcia Yes

Trustee Merrick Yes

4. PUBLIC INPUT – The public is invited to address the Board for up to 3 minutes.

No Public Input

5. WORK SESSION

a) Fiscal Year 2022-2023 Preliminary Budget

Mayor Barraza: reviewed the process that will be followed.

1 Ms. Bush: reviewed the 2022-2023 Preliminary Budget. Any changes will be done before submitting the
2 final budget.
3
4 Mayor Barraza: there will be changes will be in personnel salaries, operating expenses will remain the same as
5 2021-2022. Projected revenue for 2022-2023 is \$2.67 million, an increase of 8% based on GRT numbers;
6 projected expenditures is \$1.9 million. Once final adjustments are done left over monies will be given to the
7 departments to plug it in where it is needed.
8
9 Ms. Bush: the numbers will be reduced since there is still payroll and bills to pay through the end of June.
10
11 Mayor Barraza: there is plenty of money to cover expenses through the end of June.
12
13 Ms. Bush: reviewed the different funds and the projections for 2022-23.
14
15 Mayor Barraza: asked Ms. Bush to show the numbers reflecting a 3% and a 5% COLA increase. We have
16 exceeded what was projected for this fiscal year, so she feels comfortable giving a 5% COLA and the
17 projections since there are two more months of GRT.
18
19 Mayor Pro Tem Johnson-Burick: YTD reflects a 42% increase in local taxes.
20
21 Mayor Barraza: reiterated there are two more months of GRT coming in for this fiscal year. She continues to
22 be conservative in the projections and look at the trend.
23
24 Trustee Cadena: asked for clarification of administrative fees.
25
26 Mayor Barraza: administrative fees are for film permits, boring permits, community center, park, animal
27 registration fees and plaza rentals, etc. Some salaries are paid from those fees.
28
29 Ms. Bush: reviewed the expense line items.
30
31 Mayor Barraza: line items are self-explanatory. Changes to the salary line items are due to tax or benefit
32 increases. She will meet with Judge Toomey to review his budget; it will be at his discretion to give his clerk
33 the 5% increase.
34
35 Trustee Garcia: asked about a line item for the alternative judge.
36
37 Ms. Maya: Alternative Judge Lerma asked that he not be compensated.
38
39 Ms. Bush: budget is work in progress.
40
41 Mayor Barraza: town is charged for every day someone is jail at \$162.00
42
43 Mayor Pro Tem Johnson-Burick: why was only \$32,000 budgeted.
44
45 Mayor Barraza: that has been the history of what was being paid in prior years. Fees are imposed by the state
46 statute and sent to the state monthly.
47
48 Trustee Cadena: revenues do not even come close to the expenditures.
49
50 Mayor Barraza: those fees are at the Judge's discretion.
51
52 Trustee Cadena: expenditures need to be applicable to revenue.
53
54 Mayor Barraza: feels the concern is with prisoner care line item. Some of the funds are restricted.

1 Ms. Bush: we will need to speak to the judge and do some research. There is a lot of work to be done.
2
3 Trustee Cadena: past years it was consistent at around \$32,000; this year it is at \$92,000. She feels this is a
4 good budget.
5
6 Mayor Barraza: asked if the board is okay with giving the employees a 5% raise.
7
8 Trustee Merrick: asked on what is the 5% based on.
9
10 Mayor Barraza: it is based on their yearly salary. This is based on our revenue for the fiscal year. We also
11 need to be cautious as fuel cost are increasing.
12
13 Trustee Merrick: asked about the 5% increase received by Fire Chief Hoban.
14
15 Mayor Barraza: the Town of Mesilla Personnel Rules and Regulations reads that an employee will receive a
16 5% longevity increase every five years on their anniversary date. This will be in addition to the COLA.
17
18 Trustee Merrick: that is in the handbook for review.
19
20 Ms. Bush: the budget reflects the hourly and annual information.
21
22 Mayor Barraza: Ms. Bush and Mr. Padilla will get \$1,000 after their probation period which is included in the
23 proposed budget. Ms. Maya and Marshal Salas will be receiving the longevity increase which is also included
24 in the proposed budget, if approved by the board.
25
26 Mayor Pro Tem Johnson-Burick: needs to be done on the employee's anniversary date and not sooner.
27
28 Mayor Barraza: Ms. Maya and Marshal Salas's anniversary date was prior to the handbook being approved in
29 December, so do they not want to give the increase to them.
30
31 Mayor Pro Tem Johnson-Burick: she thought the increase was being given early but now she understands they
32 are getting it later. She agrees they should receive the increase.
33
34 Trustee Garcia: the longevity increases, and COLA increases are two separate things.
35
36 Mayor Barraza: the longevity increase can not be retroactive.
37
38 Trustee Garcia: the 5% is not even a \$1.00 for some employees. She would like to give them a little more.
39
40 Mayor Barraza: we need to consider operating expenses as fuel and supplies have doubled from last year.
41
42 Trustee Garcia: asked if this can be revisited in mid-year. New employees are coming in at same or higher
43 salaries than the existing employees.
44
45 Mayor Barraza: our goal is to bring the employees up or exceed the \$15.00 an hour.
46
47 Trustee Merrick: we need to look at the employee's performance level, what they do and what they need to
48 do.
49
50 Mayor Pro Tem Johnson-Burick: we are being generous by giving a 5% increase; other government entities
51 are not doing that.
52
53 Mayor Barraza and Trustee Cadena left to the Ride of Silence at 6:14 p.m.
54

1 Trustee Merrick: funds collected in the court are allocated.
2
3 Ms. Bush: correct they are restricted.
4
5 Trustee Garcia: Fire Chief Hoban's 5% longevity increase was not in the budget.
6
7 Trustee Merrick: there is a larger picture to the budget.
8
9 Ms. Bush: there is the day-to-day operation, and the board is a finance board. The process is you look at
10 policies and how they affect the budget; then make necessary adjustments.
11
12 Mayor Pro Tem Johnson-Burick: she thought Department Heads were between \$50,000 and \$55,000 how did
13 the fire chief get where he is at.
14
15 Ms. Bush: some of the numbers did not add up when she looked at the previous budget. She used the numbers
16 from the report created through Incode. She will do a lot of cleaning up.
17
18 Mayor Pro Tem Johnson-Burick: pay adjustments were being done without going through the board.
19
20 Trustee Merrick: agreed those adjustments should go through the board as a finance board.
21
22 Ms. Bush: her concern is the number of funds and line items currently in place.
23
24 Mayor Pro Tem Johnson-Burick: feels things were done without informing the board; not transparent. She
25 wants to get her facts straight to see if there was differential treatment that was not brought to the board.
26
27 Ms. Bush: the budget has not been managed well but going forward she wants to ensure things are transparent
28 and keep the board informed. She will be cleaning it up as it goes along.
29
30 Trustee Merrick: inaudible
31
32 Mayor Pro Tem Johnson-Burick: the money for the film project is not in the budget.
33
34 Trustee Merrick: they asked for \$20,000 which we cannot do so we recommended \$10,000.
35
36 Ms. Bush: looking at our budget \$20,000 is not a lot.
37
38 Trustee Garcia: would rather give the \$20,000 to the staff.
39
40 Mayor Pro Tem Johnson-Burick: would rather put that money back into the community.
41
42 Ms. Bush: any budget concerns should be brought to her attention prior to the worksession on Monday.
43
44 Trustee Cadena: asked if Ms. Bush has seen any major changes.
45
46 Ms. Bush: this is the year for cleanup. The COLA is not a raise.
47
48 Trustee Merrick: there are a lot of variables to increases.
49
50 Mayor Barraza and Trustee Cadena returned to worksession 6:38 p.m.
51
52 Mayor Barraza: only 50% of the COVID monies has been received. They will be looking at creating a salary
53 schedule.
54

1 Trustee Merrick: people want to be able to retire from Mesilla. She looks at it as a money thing. There is a
2 bigger picture to the budget.

3
4 Mayor Barraza: Mesilla cannot complete with the surrounding entities. She would like to keep our staff and
5 ensure there would not be a furlough as it happened in the past.

6
7 Trustee Cadena: asked if Mesilla has a grant writer.

8
9 Mayor Barraza: she will contact the A.J. for assistance.

10
11 Trustee Cadena: there is currently money for outdoor recreation.

12
13 Mayor Barraza: she forwarded that information to Ms. Sellers. Unfortunately, we do not have the staff to
14 manage those grants or the funds to hire someone.

15
16
17 Worksession ended at 7:08 p.m.

18
19
20
21 **6. ADJOURNMENT**

22 **The Town of Mesilla Trustees unanimously agreed to adjourn the meeting. (Summary: Yes-4).**

23
24 **MEETING ADJOURNED AT 7:08 P.M.**

25
26 **APPROVED THIS 13th DAY OF JUNE, 2022.**

27
28
29
30 _____
31 **Nora L. Barraza**
32 **Mayor**

33
34 **ATTEST:**

35
36
37 _____
38 **Rani Bush**
39 **Town Clerk/Treasurer**
40
41
42



1
2
3
4
5
6
7
8
9
10
11
12
13
14
15
16
17
18
19
20
21
22
23
24
25
26
27
28
29
30
31
32
33
34
35
36
37
38
39
40
41
42
43
44
45
46
47

BOARD OF TRUSTEES (BOT)
TOWN OF MESILLA
REGULAR MEETING
MONDAY, MAY 23, 2022 AGENDA

WORK SESSION – 5:00 P.M.

TRUSTEES: Nora Barraza, Mayor
Stephanie Johnson-Burick, Mayor Pro Tem
Biviana Cadena, Trustee
Veronica Garcia, Trustee
Adrianna Merrick, Trustee

STAFF: Rani Bush, Town Clerk/Treasurer
Kevin Hoban, Fire Chief
Rod McGillivray, Public Works Director
Enrique Salas, Marshal
Gloria Maya, Recorder

PUBLIC: Susan Krueger
Anthony Lucero

1. Fiscal Year 2022-2023 Budget

Mayor Barraza: Ms. Bush needed to make corrections to line items and do some clean ups. There are changes that will be done during the year that need to be reflected in the budget. We are at a 32% increase in GRTs compared to last year. Current minimum wage is at \$11.50 and will go up January 1, 2023. The 5% increase will put the employees at \$12.00 an hour.

Ms. Bush: reviewed the preliminary Fiscal Year 2022-2023 Budget.

Trustee Merrick: asked which employees are salaried.

Mayor Barraza: Department Heads are salaried.

Trustee Merrick: asked about the Enterprise Fund line items; salaries and utility rates.

Mayor Barraza: solid waste expenditures and revenues are not balancing.

Ms. Bush: salaries are being charged to that line item.

Mayor Pro Tem Johnson-Burick: based the rates.....

1 Mayor Barraza: at one time there was not enough money in the General Fund to pay some of the Public Works
2 employees' salaries, so they were moved to the Enterprise Fund.
3
4 Trustee Merrick: concerned with being able to meet the \$15.00 an hour minimum wage rate.
5
6 Trustee Garcia: other places are giving a .50 increase (annually) until the \$15.00 is met.
7
8 Trustee Merrick: asked if they can help break the budget down and help them get a better understanding.
9
10 Ms. Bush: broke it down by department for a better understanding.
11
12 Mayor Barraza: in the past there was a power point presentation which helped the board understand the
13 budget.
14
15 Trustee Merrick: trying to understand why salaries are being charged to solid waste as fund is in the red.
16
17 Mayor Barraza: expenses are high so it may not be because of salaries; that was not anticipated in last year's
18 budget.
19
20 Trustee Merrick: she wants to be able to know what we get and what we are spending when she goes to Santa
21 Fe to ask for money.
22
23 Mayor Barraza: legislators look at Capital Outlay monies. We are fortunate that there is money in the budget
24 to cover the unexpected increase in expenditures.
25
26 Fire Chief Hoban: we have been able to avoid furloughs as we had to do in the past.
27
28 Mayor Barraza: Solid waste RFT is not until next year.
29
30 Ms. Bush: Southwest Disposal bought out Mesilla Valley Disposal.
31
32 Mayor Barraza: CPI will go up in July so utility rates will increase.
33
34 Ms. Bush: she understands it is around 2%.
35
36 Mayor Barraza: we will be looking at increasing our utility rates as Mesilla's rates are not even close to rates
37 around the area. Those increases will be done gradually and according to the CPI. Also, there is a need to
38 increase property taxes.
39
40 Trustee Cadena: some fund line items are in the negative.
41
42 Mayor Barraza: Department Heads can transfer money from one line item to another in operating expenses to
43 cover deficits; cannot touch salary line item. Transfers submitted to the state must come to the board for
44 approval.
45
46 Trustee Cadena: budgeting higher than what was actually spent according to the printout.

1
2
3
4
5
6
7
8
9
10
11
12
13
14
15
16
17
18
19
20
21
22
23
24
25
26
27
28
29
30
31
32
33
34
35
36
37
38
39
40
41
42
43
44
45
46
47
48

Mayor Barraza: some of the expenses that were budgeted are not paid until the end of the fiscal year which makes the budget look like there is a balance. Also, someone made have dropped benefits, etc. which changes what was budgeted. Department Heads know they must stay within their budget. Unexpected emergencies need to come out of the budget.

Trustee Cadena: asked if the court comes to the board to hire personnel.

Mayor Barraza: court is judicial and is separate from executive legislative and administration. Judge can do what he wishes as long as he stays within his budget.

Trustee Garcia: asked about the Court Bailiff.

Mayor Barraza: the bailiff is paid through the other expenses line item. She was not aware of the hiring at the time it was done. Planning to meet with the judge once he comes back to see what he wants to do.

Trustee Merrick: asked about a creating a pay ladder.

Mayor Barraza: we will be looking at a pay chart for salaries.

Worksession ended at 5:56 p.m.

1 **MEETING – 6:00 P.M.**

2
3
4 **TRUSTEES:** Nora Barraza, Mayor
5 Stephanie Johnson-Burick, Mayor Pro Tem
6 Biviana Cadena, Trustee
7 Veronica Garcia, Trustee
8 Adrianna Merrick, Trustee
9

10 **STAFF:** Rani Bush, Town Clerk/Treasurer
11 Kevin Hoban, Fire Chief
12 Rod McGillivray, Public Works Director
13 Enrique Salas, Marshal
14 Gloria Maya, Recorder
15

16 **PUBLIC:** Susan Krueger Anthony Lucero
17 Natalie Ogas S. McBoney
18 Crystal Davis-Whited Greg Whited
19
20

21 **1. PLEDGE OF ALLEGIANCE**

22 Mayor Barraza led the Pledge of Allegiance.
23

24 **2. ROLL CALL & DETERMINATION OF A QUORUM**

25 **Roll Call.**

26 **Present:** Mayor Barraza, Mayor Pro Tem Johnson-Burick, Trustee Cadena, Trustee Garcia, Trustee Merrick.
27

28 **3. CHANGES TO THE AGENDA & APPROVAL**

29 Trustee Cadena requested removing New Business item a and to be placed on the May 31, 2022, Special
30 Meeting on agenda.
31

32 **Motion: To approve agenda as amended, Moved by Trustee Garcia, Seconded by Trustee Merrick.**
33

34 **Roll Call Vote:** Motion passed (summary: Yes =4).

35 Mayor Pro Tem Johnson-Burick Yes
36 Trustee Cadena Yes
37 Trustee Garcia Yes
38 Trustee Merrick Yes
39

40 **4. PUBLIC INPUT – The public is invited to address the Board for up to 3 minutes.**

41 Ms. Krueger inaudible
42

43 Mr. Lucero stated there was a good article in Sunday’s paper. His concern is being treated fairly.
44

45 **5. APPROVAL OF CONSENT AGENDA: (The Board will be asked to approve by one motion the**
46 **following items of recurring or routine business. The Consent Agenda is marked with an asterisk *)**

47 **Motion: To approve agenda, Moved by Mayor Pro Tem Johnson-Burick, Seconded by Trustee Garcia.**
48

49 **Roll Call Vote:** Motion passed (summary: Yes =4).

50 Mayor Pro Tem Johnson-Burick Yes
51 Trustee Cadena Yes
52 Trustee Garcia Yes
53 Trustee Merrick Yes
54

55 a) ***BOT MINUTES - Minutes of Regular Meeting, May 9, 2022. *Approved by consent***
56 ***agenda***

1 **6. PUBLIC HEARING**

2 **a) Fiscal Year 2022-2023 Budget**

3
4 **Motion: To close Regular Meeting and open Public Hearing, Moved by Mayor Pro Tem Johnson-**
5 **Burick, Seconded by Trustee Garcia.**

6
7 **Roll Call Vote:** Motion passed (**summary:** Yes =4).
8 Mayor Pro Tem Johnson-Burick Yes
9 Trustee Cadena Yes
10 Trustee Garcia Yes
11 Trustee Merrick Yes

12
13 **Opened Public Hearing at 6:08 p.m.**

14
15 Mayor Barraza reviewed the proposed budget.

16
17 **Motion: To close Public Hearing and open Regular Meeting, Moved by Mayor Pro Tem Johnson-**
18 **Burick, Seconded by Trustee Garcia.**

19
20 **Roll Call Vote:** Motion passed (**summary:** Yes =4).
21 Mayor Pro Tem Johnson-Burick Yes
22 Trustee Cadena Yes
23 Trustee Garcia Yes
24 Trustee Merrick Yes

25
26 **Opened Regular Meeting at 6:10 p.m.**

27
28
29 **7. NEW BUSINESS**

30
31 **a) For Approval:** Submission of Interim Fiscal Year 2022-2023 Budget *Removed from*
32 *agenda*

33 **b) Discussion:** Process after an Appeal Denial

34 Mayor Barraza stated there still are questions regarding the appeal process. The process must be followed;
35 starting with the PZHAC and if the applicant wants to take it further the final step is going to District Court.
36 The Board of Trustees decision is final and conclusive. The applicant has the right to choose what he would
37 like to do. The board must follow the ordinances when deciding on cases.

38
39 Trustee Garcia asked how long the wait is to reapply.

40
41 Mayor Barraza responded Mr. Cervantes was going to do research on the timeframe.

42
43 Trustee Garcia stated we do not have a timeline.

44
45 Mayor Barraza stated we will get clarification from Mr. Cervantes.

46
47 Trustee Garcia stated Mr. Cervantes had indicated that the board can waive a one year waiting period.

48
49 Mayor Barraza stated she is confused since the ordinance reads the Board of Trustees decision is final and
50 conclusive.

51
52 Trustee Garcia asked when they will be able to get clarification.

53
54 Mayor Barraza stated she will reach out to Mr. Cervantes.
55

1 **8. BOARD OF TRUSTEE COMMITTEE REPORTS**

2 Trustee Merrick: Policy Board meeting Wednesday a.m.

3
4 Mayor Pro Tem Johnson-Burick: MPO meeting Wednesday, June 8th

5
6 Trustee Garcia: Architectural Style Meeting Tuesday, May 24th.

7
8 Mayor Barraza: MPO meeting, Ride of Silence, Judge Investment Ceremony

9
10 **9. BOARD OF TRUSTEE/STAFF COMMENTS**

11 Fire Chief Hoban stated Firefighter Javier Sanchez graduated. There are some restrictions around the state
12 regarding fireworks, he will keep the board informed.

13
14 Mayor Pro Tem Johnson-Burick stated as work continues on the budget, she wants them to keep in mind that
15 they had discussed putting aside \$10,000.00 for the film industry.

16
17 Trustee Cadena stated she attended MOLI training. She appreciates hearing public comments.

18
19 Trustee Merrick stated the board has different ideas, but their primary goal is to preserve the history of Mesilla.
20 She is available to help with the budget if needed. Feels they are doing a good job in following the
21 ordinances. We need to move forward in seeing how we can help our residents.

22
23 Mayor Barraza stated she was not sure what the amount was for the film industry.

24
25 Trustee Merrick responded the board wanted to see the budget before deciding on the amount.

26
27 Mayor Barraza stated we will look at that closer.

28
29 Mayor Pro Tem Johnson-Burick stated the board was not comfortable with the \$20,000.00.

30
31 Mayor Barraza stated the board received an email from Ms. Krueger regarding the zoning of a property. That
32 property was zoned commercial in 1996; signed of by Mayor Aranda. We will be updating the information
33 with the county. MOLI training was well attended. Offices will be closed on Monday in observance of
34 Memorial Day. There is a Special Meeting regarding the budget scheduled for Tuesday, May 31st. Municipal
35 League Board of Director’s Meeting on Saturday, June 4th. Next meeting will June 13th. The article in
36 Sunday’s paper was well written. Agrees with Trustee Cadena that the board welcomes public comments.

37
38 **10. ADJOURNMENT**

39 **The Town of Mesilla Trustees unanimously agreed to adjourn the meeting. (Summary: Yes-4).**

40
41 **MEETING ADJOURNED AT 6:39 P.M.**

42
43 **APPROVED THIS 13th DAY OF JUNE, 2022.**

44
45
46
47 _____
48 **Nora L. Barraza**
49 **Mayor**

50 **ATTEST:**

51
52
53 _____
54 **Rani Bush**
55 **Town Clerk/Treasurer**



1
2
3
4
5
6
7
8
9
10
11
12
13
14
15
16
17
18
19
20
21
22
23
24
25
26
27
28
29
30
31
32
33
34
35
36
37
38
39
40
41
42
43
44
45
46
47
48
49
50
51
52
53

BOARD OF TRUSTEES (BOT)

TOWN OF MESILLA

SPECIAL MEETING

TUESDAY, MAY 31, 2022

MINUTES

TRUSTEES: Nora Barraza, Mayor
Stephanie Johnson-Burick, Mayor Pro Tem
Biviana Cadena, Trustee
Veronica Garcia, Trustee (2:21 p.m.)
Adrianna Merrick, Trustee

STAFF: Rani Bush, Town Clerk/Treasurer
Kevin Hoban, Fire Chief
Enrique Salas, Marshal
Gloria Maya, Recorder

PUBLIC: Algernon D’Ammassa

Mayor Barraza held a Moment of Silence for the children and families from Uvalde, Texas.

1. PLEDGE OF ALLEGIANCE

Mayor Barraza led the Pledge of Allegiance.

2. ROLL CALL & DETERMINATION OF A QUORUM

Roll Call.

Present: Mayor Barraza, Mayor Pro Tem Johnson-Burick, Trustee Cadena, Trustee Garcia (2:21 p.m.), Trustee Merrick.

3. CHANGES TO THE AGENDA & APPROVAL

Motion: To approve agenda, Moved by Mayor Pro Tem Johnson-Burick, Seconded by Trustee Merrick.

Roll Call Vote: Motion passed (**summary:** Yes =3).

Mayor Pro Tem Johnson-Burick Yes
Trustee Cadena Yes
Trustee Merrick Yes

4. PUBLIC INPUT – The public is invited to address the Board for up to 3 minutes.

No Public Input

5. EXECUTIVE SESSION

- a) Pursuant to NMSA 1978 Chapter 10-15-1(H)(2): Discussion limited to the hiring of someone in the Utility Clerk-Receptionist Position

54 **Motion: To close Regular Meeting and enter into Executive Session Pursuant to NMSA 1978 Chapter**
55 **10-15-1(H)(2): Discussion limited to the hiring of someone in the Utility Clerk-Receptionist Position,**
56 **Moved by Mayor Pro Tem Johnson-Burick, Seconded by Trustee Merrick.**

57
58 **Roll Call Vote:** Motion passed (summary: Yes =3).
59 Mayor Pro Tem Johnson-Burick Yes
60 Trustee Cadena Yes
61 Trustee Merrick Yes

62
63 **Entered Executive Session at 2:09 p.m.**

64
65 **Motion: To enter Regular Meeting after limited discussion to the hiring of someone in the Utility Cler-**
66 **Receptionist position, Pursuant NMSA 1978 Chapter 10-15-1(H)(2); no action taken, Moved by Mayor**
67 **Pro Tem Johnson-Burick, Seconded by Trustee Merrick.**

68
69 **Roll Call Vote:** Motion passed (summary: Yes =3).
70 Mayor Pro Tem Johnson-Burick Yes
71 Trustee Cadena Yes
72 Trustee Merrick Yes

73
74 **Entered Regular Meeting at 2:15 p.m.**

75
76 **6. NEW BUSINESS**

77 **a) Approval: Hiring of the Utility Clerk-Receptionist**

78 Mayor Barraza recommended hiring Ms. Betty Clark as Utility Clerk-Receptionist.

79
80 **Motion: To approve the hiring of a Utility Clerk-Receptionist, Moved by Mayor Pro Tem Johnson-**
81 **Burick, Seconded by Trustee Merrick.**

82
83 **Roll Call Vote:** Motion passed (summary: Yes =3).
84 Mayor Pro Tem Johnson-Burick Yes
85 Trustee Cadena Yes
86 Trustee Merrick Yes

87
88 **b) Approval: Service Agreement between the Las Cruces Public School District and the Town of**
89 **Mesilla for School Resource Officer Services**

90 Mayor Barraza stated Mesilla this agreement is with the Las Cruces Public Schools for an SRO, July, 2022
91 thru June, 2023. The amount of the agreement is \$106,469.00 which does include the 5% COLA and benefits.

92
93 **Motion: To approve Service Agreement between the Las Cruces Public School District and the Town of**
94 **Mesilla for School Resource Officer Services, Moved by Mayor Pro Tem Johnson-Burick, Seconded by**
95 **Trustee Merrick.**

96
97 **Roll Call Vote:** Motion passed (summary: Yes =3).
98 Mayor Pro Tem Johnson-Burick Yes
99 Trustee Cadena Yes
100 Trustee Merrick Yes

101
102 Mayor Barraza stated she will be meeting with Marshal Salas regarding safety concerns and to ensure we are
103 prepared for emergencies.

106 **7. UNFINISHED BUSINESS**

107

108 **a) Presentation: Fiscal Year 2022-2023 Budget**

109 Ms. Bush reviewed the proposed budget by department and line item. The budget must be submitted to the
110 state by 12:00 p.m. on Tuesday, May 31st.

111

112 Trustee Merrick asked if the budget includes people we need to hire.

113

114 Ms. Bush responded yes.

115

116 Mayor Barraza stated she calculated pay according to date when an increase will go into effect.

117

118 Trustee Merrick stated stipends are not included in the totals.

119

120 Mayor Barraza stated those will be reviewed and corrected.

121

122 Trustee Garcia asked about the vacant position listed as Accounts Payable; isn't Ms. Maya Accounts Payable.

123

124 Mayor Barraza responded that position has been kept in the budget just in case there is a need to hire someone.

125 Ms. Bush has indicated there is a need for an Admin Assistant and/or file clerk. That will be listed as a
126 vacancy.

127

128 Ms. Bush responded there is a need for a file clerk who will be helping all the departments.

129

130 Trustee Garcia asked about a stipend for Mr. Rodriguez.

131

132 Mayor Barraza stated she would like to look at the salaries for our Public Works employees. The Dona Ana
133 County summer interns will be making more than our Public Work employees.

134

135 Mayor Pro Tem Johnson-Burick stated those interns are paid through grant funding which allows them to be
136 paid \$15.00 an hour. Last year the person overseeing the program was making \$50.00 an hour.

137

138 Mayor Barraza stated they are looking at putting \$800,000.00 into operating expenses.

139

140 Mayor Pro Tem Johnson-Burick asked if there are any funds that can be used for the reserve.

141

142 Mayor Barraza responded that would be carryover money. Once current fiscal year is closed, we will know
143 how much will be put into the reserve fund.

144

145 Ms. Bush reviewed the accounts, reserve, and investments.

146

147 Mayor Pro Tem Johnson-Burick stated she feels comfortable with the 5% COLA, the fact that we are being
148 cautious. She asked if they had allocated the \$10,000.00 for the film project.

149

150 Mayor Barraza responded no; we are currently working on operating expenses. We will look at budget
151 adjustments once the preliminary budget is submitted to the state.

152

153 **b) Approval:** Interim Fiscal Year 2022-2023 Budget

154 **Original Motion: To approve Interim Fiscal Year 2022-2023 Budget, Moved by Mayor Pro Tem**
155 **Johnson-Burick, Seconded by Trustee Garcia.**

156

157 **Roll Call Vote:** Motion passed (summary: Yes =4).

158 Mayor Pro Tem Johnson-Burick Yes

159 Trustee Garcia Yes

160 Trustee Cadena Yes

161 Trustee Merrick Yes

162

163 **Amended Motion: To approve Interim Fiscal Year 2022-2023 Budget; ensuring the stipends are**
164 **included in final totals, Moved by Mayor Pro Tem Johnson-Burick, Seconded by Trustee Garcia.**

165

166 **Roll Call Vote:** Motion passed (summary: Yes =4).

167 Mayor Pro Tem Johnson-Burick Yes

168 Trustee Garcia Yes

169 Trustee Cadena Yes

170 Trustee Merrick Yes

171

172 Ms. Bush will provide information to the board.

173

174 Trustee Garcia stated there will be an appreciation breakfast at Andele's on June 9th

175

176 **8. ADJOURNMENT**

177 **The Town of Mesilla Trustees unanimously agreed to adjourn the meeting. (Summary: Yes-4).**

178

179 **MEETING ADJOURNED AT 2:40 P.M.**

180

181 **APPROVED THIS 13th DAY OF JUNE, 2022.**

182

183

184

185

186

187

188

189

ATTEST:

190

191

192

Rani Bush
Town Clerk/Treasurer

193

194

195

196

197

Nora L. Barraza
Mayor

BOARD ACTION FORM

AGENDA DATE

PZHAC: June 6, 2022,

BOT:

ITEM: PZHAC Case #061376– Pappas Williamson seeking for a summary subdivision a Replat of U.S.R.S Tract 11A-199 & 11A – 198A within the Town of Mesilla, Dona Ana County, N.M. in section 25, T.23S R.1E of U.S.R.S. Surveys (2532 Calle De Norte), **Zoned: Historical Residential (HR)**

BACKGROUND AND ANALYSIS: Pappas Williamson Trust replat of 2532 Calle de Norte back section of the property to be split will be off Calle de Oeste this is the Preliminary Plat Procedure per Town Code 17.10.020

IMPACT:

- The PZHAC has jurisdiction to recommend approval of the applicant's request for approval of this request to the BOT.
- The applicant has the authority to make an application request to the PZHAC and BOT.
- Due process was provided to the applicant.

Specific findings of fact:

- The proposed work is on applicant's property and not in Town of Mesilla right-of-way.

ALTERNATIVES:

The Planning, Zoning and Historical Appropriateness Commission (PZHAC) may:

1. Recommend approval of this case with findings stated above.
2. Recommend approval of this case with findings stated above and conditions.
3. Deny the application.

DEPARTMENT RECOMMENDATIONS:

SUPPORTING INFORMATION:

- Application
- Plans

SUBDIVISION APPLICATION

OFFICIAL USE ONLY:

Case # 061376

Fee \$ 150.00

CASE NO. _____ ZONE: HR CODE: _____ APPLICATION DATE: _____

Preliminary Plat Summary Subdivision Final Plat Vacation of Lot Line

Name of Applicant: Sylvia Williamson (Trustee) Applicant's Telephone/Cell Number: 505-660-3321

Mailing Address: 1329 Cordova Ave. NW City: Albuquerque State: NM Zip Code: 87107

Owner of Record: Address: Helen Williamson Revocable Living Trust City: Albuquerque State: NM Zip Code: 87107

Name of Engineer: _____ License # of Engineer: _____ Address: _____ Telephone/Cell Number: _____

Name of Architect: GILBERT CURRIE License # of Architect: AMP 6832 Address: PO BOX 882, MESILLA NM 88046 Telephone/Cell Number: 575-649-7605

Subdivision Name: Pappas-Williamson Subdivision Location: 2537 Calle del Norte

Total Acreage: _____ Number of Lots: _____

Acreage of Largest Lot: _____ Acreage of Smallest Lot: _____

Legal Description: _____

Tax Map Property Code (s) R-0400177 Jacob's Map # 4.006-137-040-495

A ZONE CHANGE, VARIANCE, EXEMPTION, OR SPECIAL PERMIT IS ALSO BEING REQUESTED WITH THIS PROPERTY.

EXPLAIN: _____

By signing this application, you hereby acknowledge that ALL the information submitted on and with this application is true and correct to the best of your knowledge and that all provisions of the Town of Mesilla shall be met. No application will be accepted without the original signature of the owner(s) of record of the described property. If more than one owner, ALL owners must sign the application. (Attached an additional sheet if necessary).

Owner(s): Sylvia Williamson (Formerly H. Williamson) Trustee of the Helen Williamson Revocable Living Trust Date: 3-31-2022

Applicant(s) (if different than owner): _____ Date: _____

FOR OFFICIAL USE ONLY

PZHAC Administrative Approval BOT Approved Date: _____
 Approved Date: _____ Disapproved Date: _____
 Disapproved Date: _____ Approved with Conditions
 Approved with conditions

CONDITIONS: _____

Layer Visibility:

- Roads
- City Limits
- MLS Zones
- Address Labels
- 2014 Aerial Photo
- Parcels

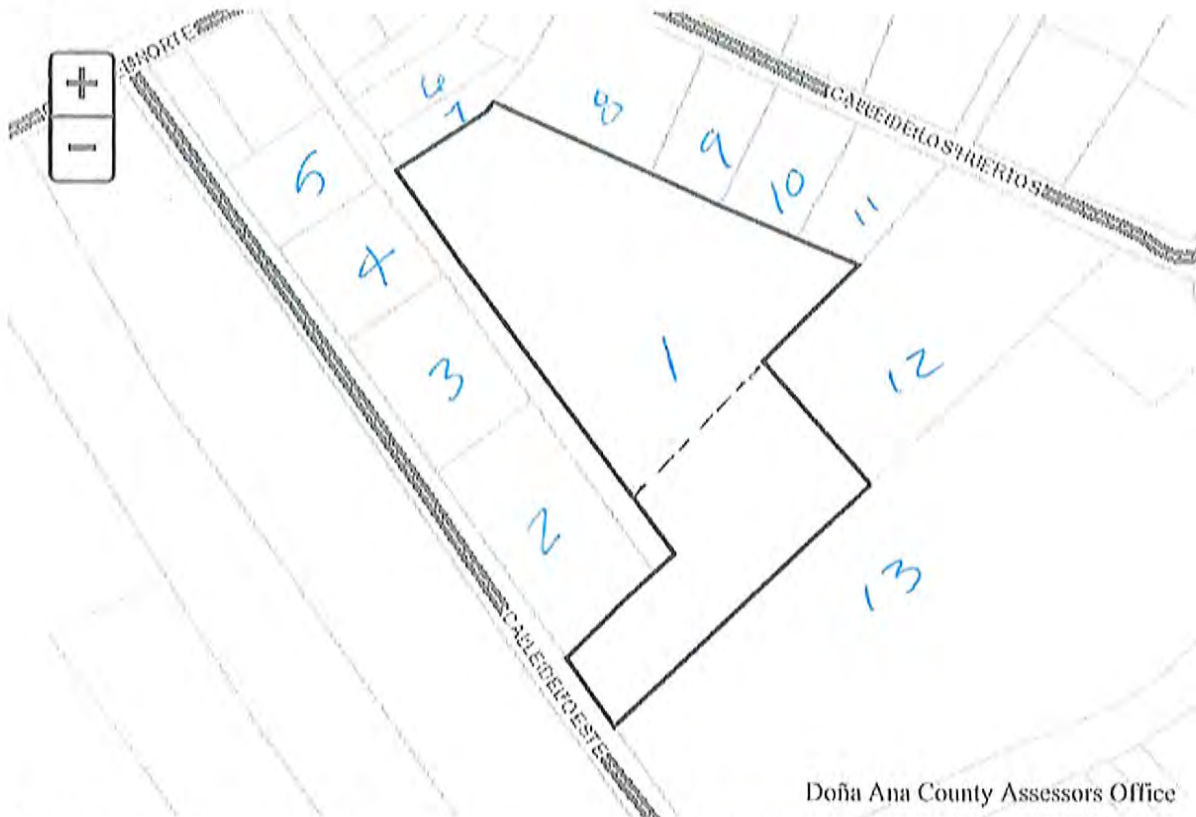

Doña Ana County Assessors Office

ACCOUNTNUMBER:	R0400177	PARCELNUMBER:	4006137040495
OWNERNAME:	WILLIAMSON HELEN PAPPAS	MAILADDR1:	PO BOX 613
CITY:	MESILLA	STATE:	NM
ZIP:	88046-0613	LOT:	
BLOCK:		SUBNAME:	
TRS:	23S 1E 25	SITUSADDRS:	2532 CALLE DEL NORTE
TOTALACRES:	3.45		

PLAT OF SURVEY OF
 A 3.75 ACRE TRACT
 U. S. R. S. TRACT 11A-199
 PROPERTY OF ERNEST PAPPAS
 MESILLA, DONA ANA COUNTY, N. M.

JULY 24, 1963
 REVISED Sept. 17,

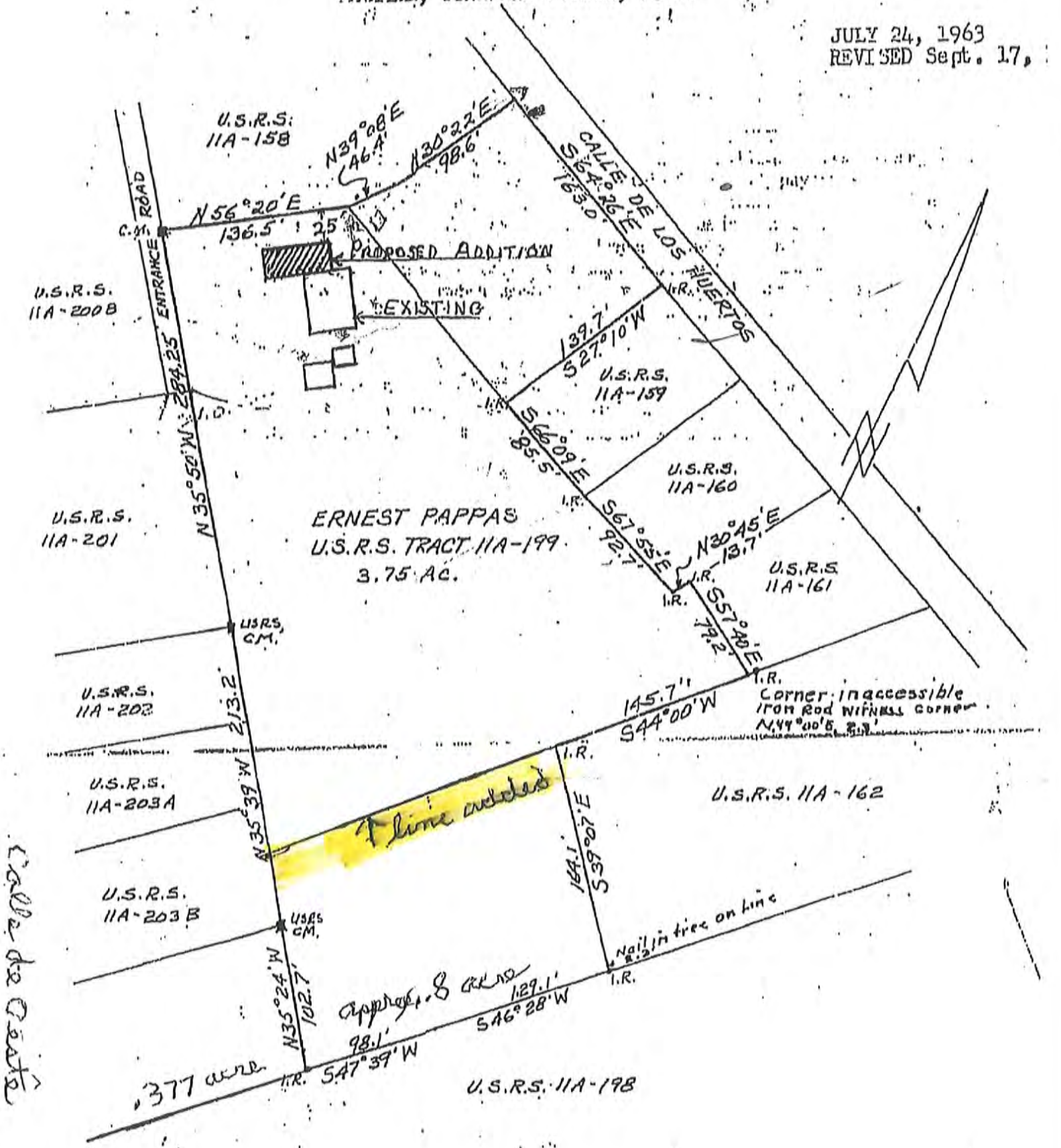

CALLE DE CRISTO

BOARD ACTION FORM

AGENDA DATE

PZHAC: June 6, 2022,

BOT:

ITEM: PZHAC Case #061384 – 2260 Calle de Santiago, submitted by Bill & Janice Cook to install rooftop solar system not visible from the street. **Zoned: Historical (HR)**

BACKGROUND AND ANALYSIS: This case was reviewed by the Architectural Styles Committee (ASC) proposed work involves installation of six roof mounted modules with bay & module clips, AC combine panel & data monitoring unit, production meter and customer generation fusible AC disconnect .

IMPACT:

- The PZHAC has jurisdiction to recommend approval of the applicant's request for approval of this request to the BOT.
- The applicant has the authority to make an application request to the PZHAC and BOT.
- Due process was provided to the applicant.

Specific findings of fact:

- The proposed work is on applicant's property and not in Town of Mesilla right-of-way.

ALTERNATIVES:

The Planning, Zoning and Historical Appropriateness Commission (PZHAC) may:

1. Recommend approval of this case with findings stated above.
2. Recommend approval of this case with findings stated above and conditions.
3. Deny the application.

DEPARTMENT RECOMMENDATIONS:

SUPPORTING INFORMATION:

- Application
- Plans

TOWN OF MESILLA
ZONING APPROVAL

OFFICIAL USE ONLY:

Case # 061384

Fee \$ 175.00

*Fee \$150.00
Remainder \$25.00*

PERMISSION TO CONDUCT WORK
OR
OBTAIN A COMMERCIAL/RESIDENTIAL BUILDING PERMIT FROM CID

2231 Avenida de Mesilla, P.O. Box 10, Mesilla, NM 88046 (575) 524-3262 ext. 104

CASE NO. 061384 ZONE: HRL CODE: AC APPLICATION DATE: 5/6/22



Bill and Janice Cook		575-202-8794	
Name of Property Owner		Property Owner's Telephone Number	
2260 Calle De Santiago	Mesilla	NM	88046
Property Owner's Mailing Address	City	State	Zip Code
thepotteriesmesilla@gmail.com			
Property Owner's E-mail Address			
Organ Mountain Solar & Electric			
Contractor's Name & Address (If none, indicate Self)			
575-202-9268	03-401215-00-0	394801	
Contractor's Telephone Number	Contractor's Tax ID Number	Contractor's License Number	

Address of Proposed Work: 2260 Calle De Santiago Mesilla, NM 88046

Description of Proposed Work: Residential Rooftop Solar Installation with ZERO visibility from street.

\$ <u>9,430</u>	<u>Scott Burns</u>	<u>5/5/22</u>
Estimated Cost	Signature of Applicant	Date

DocuSigned by:
 Signature of property owner: [Signature]

With the exception of administrative approvals, all permit requests must undergo a review process from staff, PZHAC and/or BOT before issuance of a zoning permit. Plan sheets are to be no larger than 11 x 17 inches or shall be submitted electronically.

FOR OFFICIAL USE ONLY

PZHAC	<input type="checkbox"/> Administrative Approval	BOT	<input type="checkbox"/> Approved Date: _____
	<input type="checkbox"/> Approved Date: _____		<input type="checkbox"/> Disapproved Date: _____
	<input type="checkbox"/> Disapproved Date: _____		<input type="checkbox"/> Approved with Conditions
	<input type="checkbox"/> Approved with conditions		

PZHAC APPROVAL REQUIRED: YES ___ NO BOT APPROVAL REQUIRED: YES ___ NO

CID PERMIT/INSPECTION REQUIRED: YES ___ NO ___ SEE CONDITIONS

CONDITIONS: _____

PERMISSION ISSUED/DENIED BY: _____ ISSUE DATE: _____

THIS APPLICATION SHALL INCLUDE ALL OF THE FOLLOWING:

1. Plot plan with legal description to show existing structures, adjoining streets, driveway(s), improvements & setbacks. Verification shall show that the lot was LEGALLY subdivided through the Town of Mesilla or that the lot has been in existence prior to February 1972.
2. Site Plan with dimensions and details.
3. Foundation plan with details.
4. Floor plan showing rooms, their uses and dimensions.
5. Cross section of walls
6. Roof and floor framing plan
8. Proof of legal access to the property.
9. Drainage plan.
10. Details of architectural style and color scheme (checklist included for Historical zones) – diagrams and elevations.
11. Proof of sewer service or a copy of septic tank permit; proof of water service (well permit or statement from the Public Utility providing water services).
12. Proof of legal access to the property.
13. Other information as necessary or required by the City Code or Community Development Department (See other side.)

The following are requirements to be included with all building permit applications for new structures or additions to existing structures, as well as other construction or fixtures that will be permanent in nature and affect the appearance or use of the property. (This includes fences, well houses, storage units, metal sheds, photo-voltaic panels that can be seen from the ground, etc.)

BUILDING PERMIT REQUIREMENTS

A. Completed application, including:

1. Applicant's name
2. Applicant/property owners contact information
3. Physical address of property
4. Description of work to be done, including dimensions of any construction or repairs
5. Value of work to be done
6. Property owner's signature on the application

B. Include all information required in the checklist at the bottom of the application.

C. Additional information required:

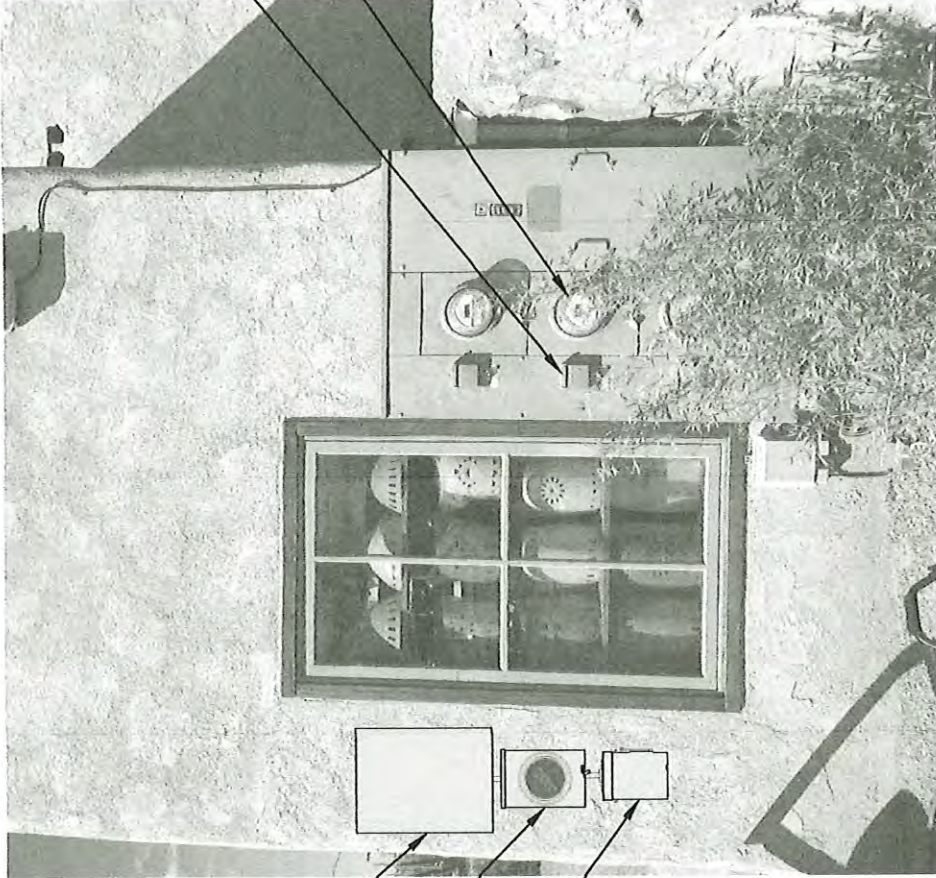

AC Combiner Panel
& Data Monitoring Unit

Production Meter

Customer Generation
Fusible AC Disconnect

Existing Main Service
Disconnect

Existing Utility Meter

Existing Service Panel
(Inside)

1 Partial Elevation
Scale: CUSTOM

REV	DESCRIPTION	DATE
0	Initial Release	5/2/22

DESIGNER: Polizois Dallis



Organ Mountain Solar
400 South Compress Road, Suite D
Las Cruces, NM 88005
(575) 288-1792

NM Electrical Contractor's License # 394801

Owner

The Potteries

Utility-Interactive Photovoltaic System
System Size = 2.22 kWdc
2260 Calle de Santiago B
Mesilla, NM 88046

PV-1.2



Organ Mountain Solar
 400 South Compress Road
 Suite D
 Las Cruces, NM 88005
 (575) 288-1792
 NM Electrical Contractor's
 License # 394801

Owner
 The Potteries
 Utility-Interactive Photovoltaic System
 System Size = 2.22 kWdc
 2260 Calle de Santiago B
 Mesilla, NM 88046

DESIGNER:
 Polizois Dallis

REV	DESCRIPTION	DATE
0	Initial Release	5/2/22

DESIGN SUMMARY

Number of Modules	6
Module Tilt Angle	10°
Module Azimuth	140°
Average Annual Shading	3.00%
Year 1 Production Estimate	4033 kWh

SITE PLAN
PV-1.0



2 **Vicinity Map**
 Scale: CUSTOM

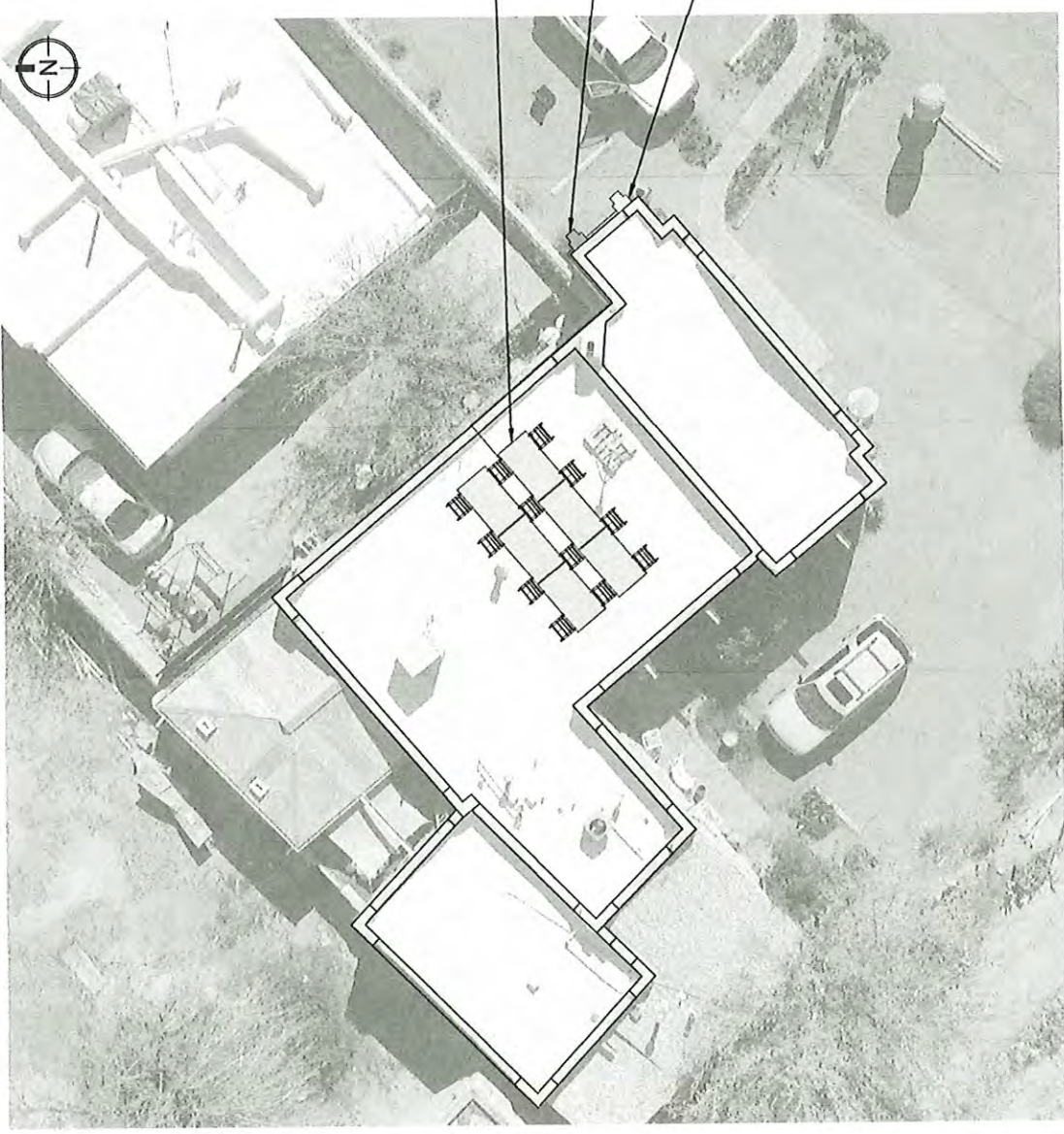

1 **Site Plan**
 Scale: 3/32" = 1'-0"

Note:
 -Special Access Instructions: None.

- Roof Mounted Array
 6 x Panasonic EverVolt Modules
 with Enphase Microinverters
- Existing Utility Meter /
 Main Service Disconnect (Outside)
- Customer Generation Fusible
 AC Disconnect / Production Meter
 AC Combiner Panel / Data Monitoring Unit
 (Outside)

SHEET NOTES

- 1 Exact location of equipment and conduit is subject to minor variations during installation.
- 2 Estimated annual energy production is based on existing site conditions and this array layout. Annual variations in weather and module degradation will affect production.

Design Approval
 I approve of this design showing all equipment and locations, and estimated production. Any change to this design may result in delays and additional costs.

Approved By: _____
 Date: _____



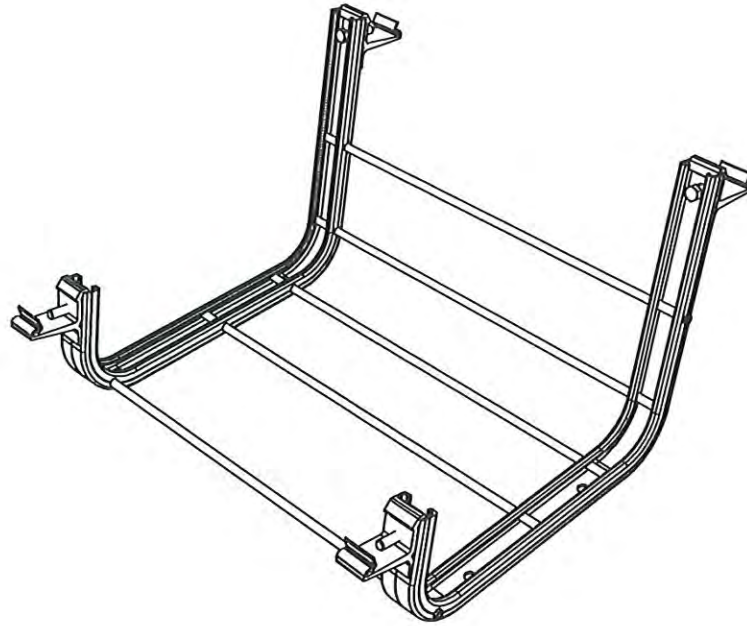

FRONT VIEW

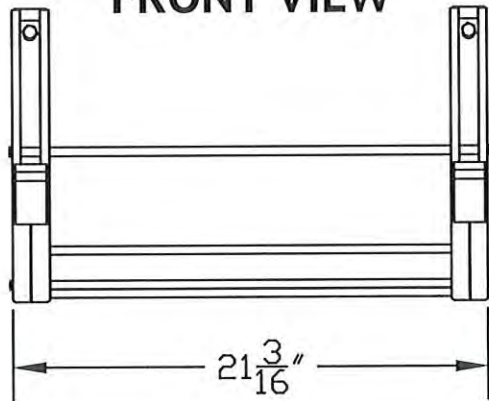

SIDE VIEW

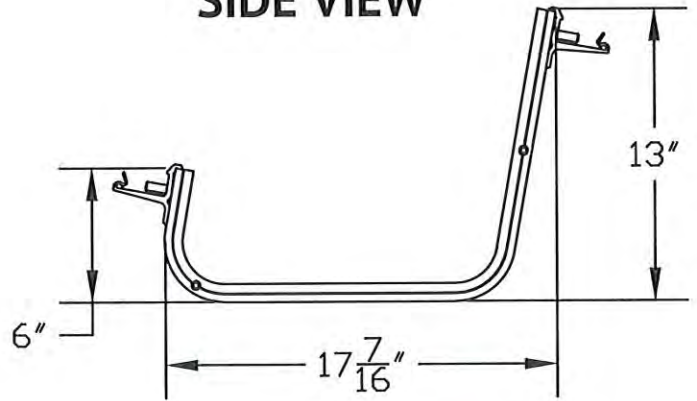

1411 BROADWAY BLVD NE
ALBUQUERQUE, NM 87102 USA

WWW.UNIRAC.COM

PRODUCT LINE:	RM
DRAWING TYPE:	COMPONENT ASSEMBLY
DESCRIPTION:	BAY & MODULE CLIPS
REVISION DATE:	APRIL - 2016

DRAWING NOT TO SCALE
ALL DIMENSIONS ARE NOMINAL

PRODUCT PROTECTED BY ONE
OR MORE US PATENTS

LEGAL NOTICE

RM-A01

SHEET

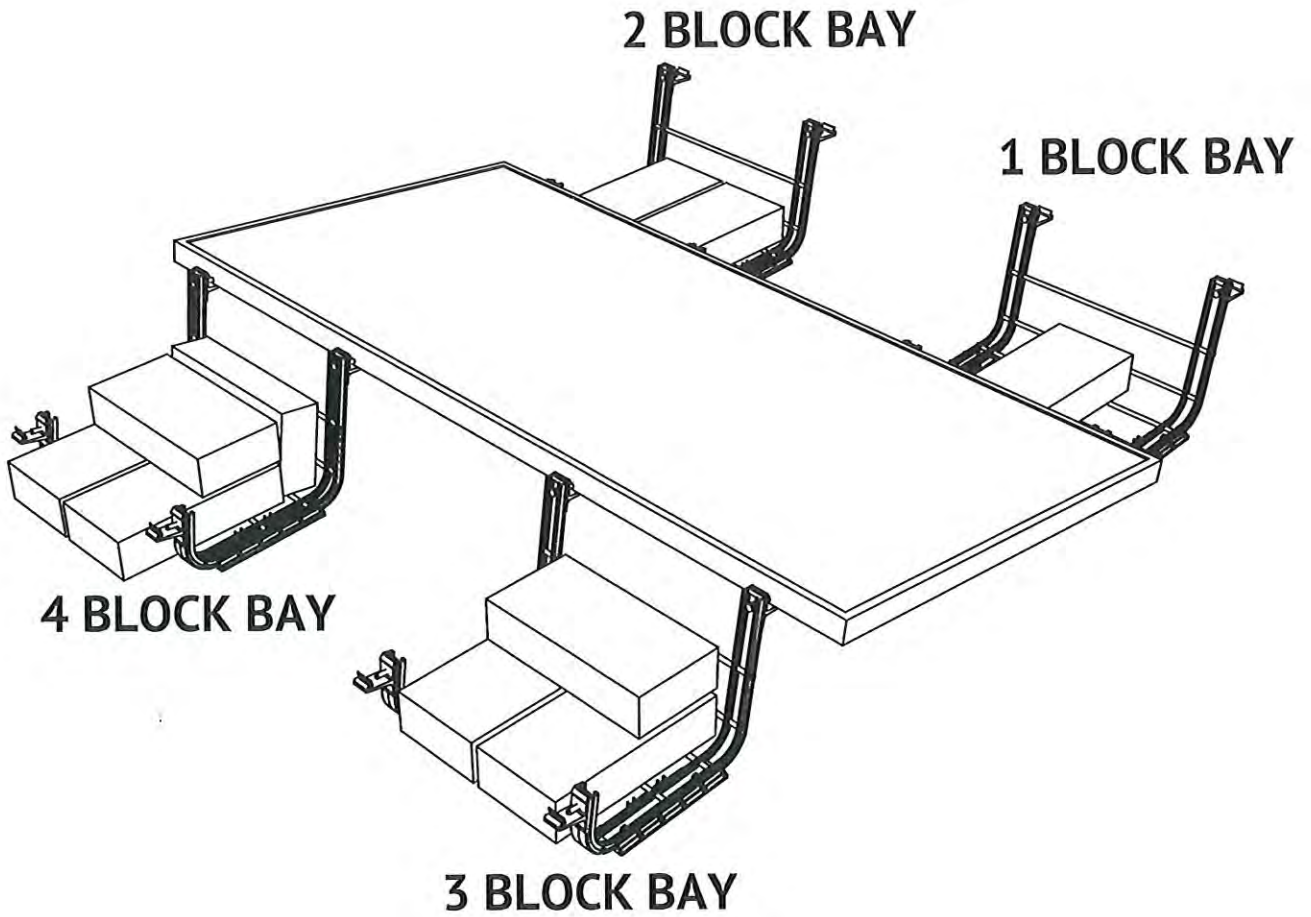

1411 BROADWAY BLVD NE
ALBUQUERQUE, NM 87102 USA

WWW.UNIRAC.COM

PRODUCT LINE:

RM

DRAWING TYPE:

ASSEMBLY

DESCRIPTION:

1-2-3-4 BLOCK RM
BAYS

REVISION DATE:

APRIL - 2016

DRAWING NOT TO SCALE
ALL DIMENSIONS ARE NOMINAL

PRODUCT PROTECTED BY ONE
OR MORE US PATENTS

LEGAL NOTICE

RM-A02

SHEET

NOTE: ARRAY DIMENSIONS WILL VARY BASED ON
MODULE WIDTH, LENGTH AND RETURN FLANGE



TOP VIEW

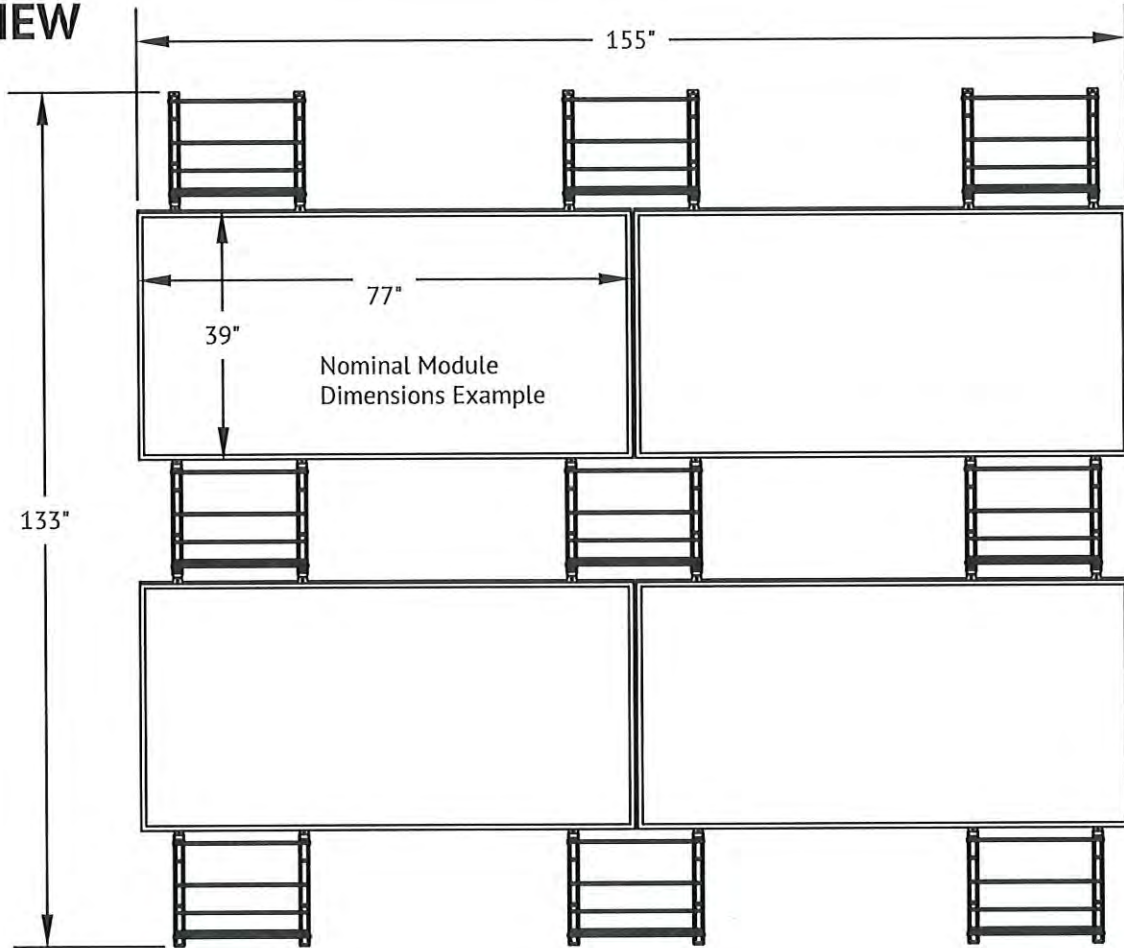

SIDE VIEW

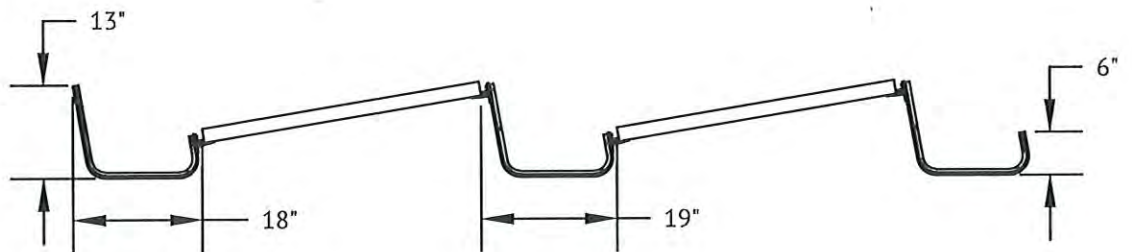

1411 BROADWAY BLVD NE
ALBUQUERQUE, NM 87102 USA

WWW.UNIRAC.COM

PRODUCT LINE:

RM

DRAWING TYPE:

ASSEMBLY

DESCRIPTION:

4 MODULE RM
LAYOUT

REVISION DATE:

APRIL - 2016

DRAWING NOT TO SCALE
ALL DIMENSIONS ARE NOMINAL

PRODUCT PROTECTED BY ONE
OR MORE US PATENTS

LEGAL NOTICE

RM-A03

SHEET

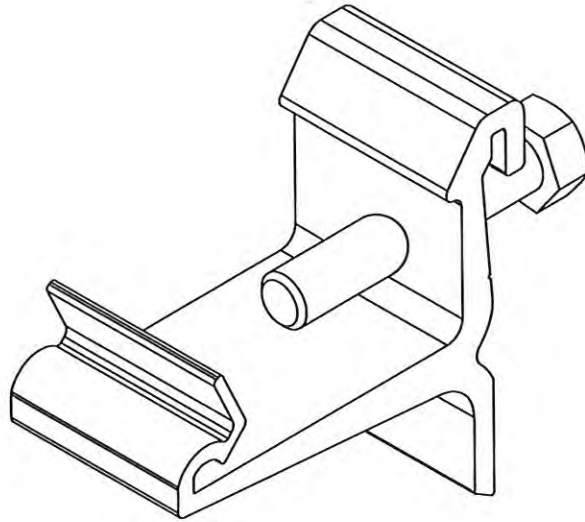

FRONT VIEW

SIDE VIEW

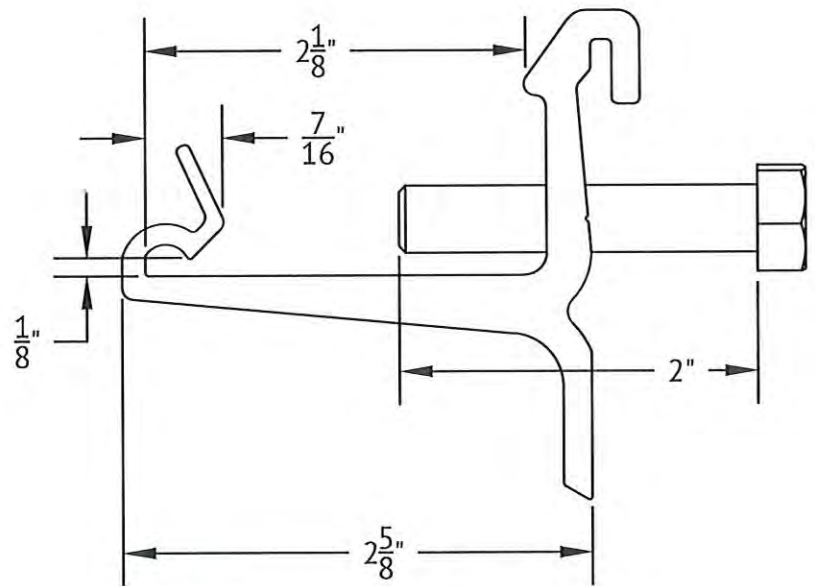
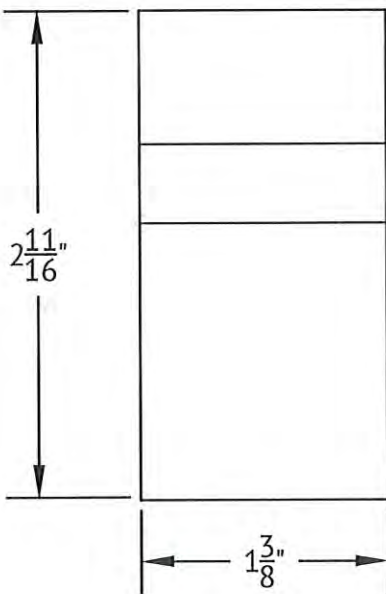

1411 BROADWAY BLVD NE
ALBUQUERQUE, NM 87102 USA

WWW.UNIRAC.COM

PRODUCT LINE:

RM

DRAWING TYPE:

PART

DESCRIPTION:

RM CLIP & BOLT

REVISION DATE:

APRIL - 2016

DRAWING NOT TO SCALE
ALL DIMENSIONS ARE NOMINAL

PRODUCT PROTECTED BY ONE
OR MORE US PATENTS

LEGAL NOTICE

RM-P01

SHEET



**EL PASO ELECTRIC COMPANY
RESIDENTIAL REQUEST FOR SERVICE FORM**

Name: The Potteries Home Phone: (575) 202-8794 Work Phone: _____
 Name: William D. Cook Home Phone: _____ Work Phone: _____

(Name and phone number of person to contact if other than customer.)

Service address: 2260 Calle De Santiago, Mesilla, NM, 88046

Mailing address: 2260 Calle De Santiago, Mesilla, NM, 88046 Box 64

New service classification:

- () Mobile Home () Multiplex/Duplex () Single Family (Sq. Ft.)
 () Permanent () Temporary Date required: _____
 () Overhead () Underground*

MINIMUM REQUIREMENTS FOR UNDERGROUND SERVICE WILL REQUIRE THE INSTALLATION OF A 200 AMP METER CAN AND 2½" CONDUIT. FOR INFORMATION REGARDING O.H./U.G. SERVICE, CONTACT YOUR PLANNER.

THE FOLLOWING INFORMATION MUST BE MADE AVAILABLE TO YOUR EL PASO ELECTRIC COMPANY PLANNER IN ORDER TO INITIATE ENGINEERING DESIGN FOR AN ELECTRIC LINE EXTENSION:

400 S Compress Rd Suite

A) Builder: Organ Mountain Solar & Ele Mailing Add.: Las Cruces, NM, 88005 Phone No. (575) 288-1792

B) Electrician: _____ Mailing Add.: _____ Phone No. _____

C) Legal description:

(A plot or site plan with dimensions that include the legal description must be provided. No action will be taken by El Paso Electric Company Design Engineers until after this information has been provided. Please indicate the desired meter location. El Paso Electric Company reserves the right to designate the meter location. Please refer to the attached checklist.)

D) Electrical load information (check applicable items).

- | | | |
|--|---|--|
| <input type="checkbox"/> Refrigerator | <input type="checkbox"/> Elec. Oven | <input type="checkbox"/> Elec. Clothes Dryer |
| <input type="checkbox"/> Freezer | <input type="checkbox"/> Microwave | <input type="checkbox"/> Gas Furnace Blower |
| <input type="checkbox"/> Elec. Range | <input type="checkbox"/> Dishwasher | <input type="checkbox"/> Waterbed Heater |
| <input type="checkbox"/> Elec. Cooktop | <input type="checkbox"/> Elec. Clothes Washer | <input type="checkbox"/> Attic Fan |

Please check the following and indicate number of units and size.

- | | |
|---|----------------|
| <input type="checkbox"/> Electric Water Heater | _____ NO./SIZE |
| <input type="checkbox"/> Heat Pumps | _____ KW |
| <input type="checkbox"/> Electric Heat | _____ KW |
| <input type="checkbox"/> Evap. Cooler | _____ KW |
| <input type="checkbox"/> Refrigerated Air | _____ HP |
| <input type="checkbox"/> Swimming Pool | _____ Tons |
| <input type="checkbox"/> Jacuzzi | _____ HP |
| <input type="checkbox"/> Domestic Well | _____ HP |
| <input checked="" type="checkbox"/> Solar | _____ KW |
| <input type="checkbox"/> Other (Hand Tools, Welders, Etc.) Please indicate no. and size of equipment. | |

Conductors Per Phase _____ Main Size _____ Wire Size _____

- E) A New Mexico Building Permit will be required if residence is located in Dona Ana County (525-6637).
 F) THE COMPANY'S REPRESENTATIVES SHALL HAVE FREE AND EASY ACCESS AT ANY TIME TO EPE EQUIPMENT LOCATED ON THE PREMISES OF THE CUSTOMER AND RESERVE THE RIGHT TO REMOVE EPE METERS AND EQUIPMENT FOR PROPER CAUSE.

Signature: William D. Cook Date: 3.10.22



Organ Mountain Solar & Electric
400 S Compress Rd, Suite D, Las Cruces, NM 88005
(575) 288-1792
License #: 394801

BUILDING IMPROVEMENT AGREEMENT (Solution A)

Contract Date: Mar 18, 2022

PARTIES This Building Improvement Agreement (“**Contract**”) is by and between the parties listed below. Contractor and Buyer are occasionally referred to herein individually as a “**Party**” and collectively as the “**Parties**.”

BUYER (Owner on Title/Deed):

The Potteries
Bill and Janice Cook
2260 Calle De Santiago
Mesilla, NM 88046
(575) 202-8794

CONTRACTOR (Seller):

Organ Mountain Solar & Electric
400 S Compress Rd Suite D
Las Cruces, NM 88005
(575) 288-1792
pmlc@omsande.com
License: 394801

SALES CONSULTANT:

Phillip Samuel
(575) 496-9169
phillip@omsande.com

EFFECTIVE DATE. Contract is effective as of the latest date referenced on the signature lines below (“**Effective Date**”)

WORK SITE. The following is a legal description of the location (the“**Premises**”) where the work by Contractor to be performed as described herein will occur:

2260 Calle De Santiago, Mesilla, NM 88046

ATTACHMENTS:

1. ATTACHMENT A: WARRANTY
2. ATTACHMENT B: DISTRIBUTED GENERATION DISCLOSURE STATEMENT
3. UTILITY INTERCONNECTION APPLICATION & DATA USAGE AUTHORIZATION

Initial Here: PS JL



The parties to this Contract agree as follows:

1. Scope of Work. Description of the Project and Description of the Significant Materials to be Used and Equipment to be Installed:

1. Residential Roof Mount PV System

Contractor will provide materials and labor to supply and interconnect a roof mounted, grid-tied solar electric (PV) system at your premises. The "Solar PV System" has a rated capacity of 2.220 DC kW (STC) and includes the following major items:

- PV Modules: (6) Panasonic EVPV370K
370W, 120 half-cut cell monocrystalline HJT module, Black backsheet, 1000V max system Vdc
- Microinverters - grid-tie: (6) Enphase Energy IQ7PLUS-72-2-US (240V)

The Contractor shall furnish all the necessary design documents, permitting and utility interconnection agreements, and all materials, equipment, and labor to complete the defined scope of work. Commissioning & testing of the equipment will occur after the installation to ensure proper system functionality.

2. Time of Completion. The work to be performed under this contract is dependent on a variety of variables, including, but not limited to, completion of design site survey, customer design approval, financing, jurisdiction and utility permitting approval, project-related work outside the scope of work for the Contractor (e.g. roof work, electrical work, etc.)

3. Price and Payment Schedule. The Customer shall pay the Contractor for the work to be performed under this agreement in accordance with the following:

CONTRACT PRICE: \$9,430.00

Payment Method: cash

SCHEDULE OF PROGRESS PAYMENTS. Total Price will be paid according to the schedule defined below:

#	Event	Description	Portion	Amount
1	Project Closing	Engineering payment due at contract signing	\$2,000.00	\$2,000.00
2	Equipment Acquisition	Invoice sent 45 days prior to scheduled installation Date	32.21 % of Balance	\$2,715.00
3	Installation Date	Invoice sent on installation date	32.21 % of Balance	\$2,715.00
4	System Activation	Invoice sent for outstanding balance upon system activation	Balance	\$2,000.00
Contract Cost			Initial Here: <i>PK</i> <i>JL</i>	\$9,430.00

Deposit (if any) is due at time of contract signing. Payment to Contractor may be made by cash, check or wire transfer.

NOTES:

- The pricing in this Contract is valid for 10 days after the date that Contractor first presents it to you for execution. If you do not sign and return this Contract to Contractor within this 10-day period, Contractor reserves the right to reject this Contract unless you agree to Contractor's then current Contract Price.
- The Contract Price is inclusive of any and all taxes and/or standard fees due as a result of the Work, which shall in all cases be the sole responsibility of the Contractor to pay to the appropriate government entity.

4. Final Invoice. The Customer shall pay the remainder of the Contract Price within 15 business days after receiving the final invoice (final invoice is defined by the payment schedule in section 3).

5. Customer's Warranties & Responsibilities.

- a. Customer warrants and represents that he/she is not only the owner of the location where the System will be installed, including work performed, but also assumes responsibility, and is thus responsible for any future potential conflicts, of property lines, restrictive covenants, and rights of easement owner(s).
- b. The Customer will provide the Contractor any and all required surveys, legal descriptions, etc. that may be necessary for designing and permitting the Work.

6. General Provisions and Change Orders. Any alterations or deviation to the above specifications, including, but not limited to, any such alteration or deviation involving changes in materials and/or labor costs, will be executed only upon a written order for same, signed by the Customer and the Contractor. If there is any change in price for such alteration or deviation, initiated by either the Customer or Contractor, a change order will be issued, for which the change in price must be mutually agreed in writing, signed by both parties, and added to, or subtracted from, the contract price of this contract.

7. Work Quality. All work shall be completed in compliance with all building and electrical codes, all other applicable laws, and all applicable utility requirements, including appropriate utility interconnection obligations.

8. Project Approval. The Contractor shall furnish to the Customer the following documents for approval, which will need to be signed and dated by the Customer prior to procurement of materials.

- a. **Site Map 1** Top-down overview of the project site illustrating module layout and equipment placement.
- b. **Site Map 2** Rendering of the Balance of System (BOS) equipment next to the Utility equipment. (BOS is defined in this context to mean the solar meter, combiner enclosure, and required electrical switch gear.)

9. Licensing. To the extent required by the law, all work shall be performed by individuals duly licensed and authorized by law to perform said work.

10. Subcontractors. Contractor may at its discretion engage subcontractors to perform work hereunder, provided Contractor shall fully pay said subcontractor and in all instances remain responsible for the proper completion of this Contract.

11. Insurance. Contractor warrants that it has and will maintain insurance coverage adequate for the work being performed, including general liability insurance and Workers Compensation insurance as required by law.

12. Permits. Contractor shall obtain all permits necessary for the work to be performed.

13. Site Maintenance. Contractor agrees to remove all debris and leave premises in same condition as when work commenced.

14. Warranty. Contractor warrants all work for a period of (120) one-hundred and twenty months following completion.

15. Data Monitoring. Real-time monitoring requires access to the Customer's internet, which must be provided by the Customer.

a. Failure of data monitoring system due to the failure of communications equipment may result in a service call fee upon Customer request.

16. Conflict of Interest. Contractor represents that it has no conflicts of interest that might interfere with its performance under this Contract. Contractor further represents that it will immediately inform the Customer of any conflicts which arise or may arise during the term of this Contract by written notice to the Customer. The Customer and Contractor shall immediately address any such conflicts or potential conflicts as they may arise. If Contractor presently has any obligations or affiliations from which such a conflict might in the future arise, Contractor will provide written notice to this effect to the Customer on or before execution of this contract.

17. Termination of Contract. Termination by Either Party: This Contract may be terminated by either party due to conditions or occurrences that increase the cost of the Work by more than 5%. In such an instance, the Customer shall pay Contractor for all parts of the Work done and shall pay Contractor an amount equal to all non-refundable deposits and payments made by the Contractor prior to the date of termination, including materials provided. Additionally, the Customer shall pay to the Contractor an amount equal to Contractor's substantiated, reasonable direct costs necessarily incurred by the Contractor (a) in procuring materials and equipment, (b) in preparation for the parts of the Work not yet performed and (c) in demobilizing and stopping work hereunder, provided that the total sum payable to Contractor upon termination shall not exceed the unpaid balance of the Contract Price. Contractor shall be entitled to its overhead & profit in the proportion that its costs to be reimbursed bear to the Contract Sum. Contractor shall not be entitled to any other costs or damages whatsoever arising out of Contractor's performance of the Work.

18. Billable Work. Billable work begins upon our Design Site Survey and any cancellation thereafter will result in Customer being billed for all time and material costs accrued on and after that date. The billable amount will be deducted from any refund due.

19. Indemnification and Limitation of Liability. Each Party will indemnify and defend the other Party and its directors, officers, employees, agents, representatives, and affiliates and hold them harmless from and against any and all losses, liabilities, damages, claims, suits, actions, judgments, assessments, costs and expenses, including without limitation interest, penalties, attorney fees, any and all expenses incurred in investigating, preparing, or defending against any litigation, commenced or threatened, or any claim whatsoever, and any and all amounts paid in settlement of any claim or litigation asserted against, imposed on, or incurred or suffered by any of them, directly or indirectly, as a result of or arising from the negligent or wrongful acts or omissions of the other Party, from any breach of this Agreement by the other Party, or from any finding, judgment or other determination or settlement whereby the Customer is deemed or considered to be the employer of Contractor or of Contractor's Personnel.

20. Arbitration. Any disputes which may arise under this Agreement and which cannot be resolved by the Parties through good faith negotiation will be submitted to arbitration. In the event of a dispute that cannot be resolved among the parties, either party may: for disputes valued at or below \$25,000, submit the dispute to binding mediation; or for disputes valued above \$25,000, submit the dispute to binding arbitration. During the pendency of the dispute resolution, all Work shall cease unless the parties agree otherwise.

21. Legal Fees. In event legal action is instituted by either party hereto, the prevailing party shall be entitled to reasonable attorney's fees and costs incurred in prosecuting or defending such action.

22. Force Majeure. Notwithstanding anything contained in this Agreement to the contrary, neither Party will be deemed liable or to be in default for any delay or failure in performance under this Agreement deemed to result, directly or indirectly, from acts of God, acts of civil or military authority, acts of public enemy, war, or any like cause beyond its reasonable control unless such delay or failure in performance is expressly addressed elsewhere in this Agreement.

Initial Here: _____

pd

jc

23. Governing Law and Venue. This Agreement will be interpreted and enforced according to the laws of the state of New Mexico. Any proceeding to compel arbitration or to enforce an arbitration award is to be brought against any of the Parties in Dona Ana County Circuit Court of the State of New Mexico and each of the Parties consents to the jurisdiction of such court (and of the appropriate appellate court) in any such action or proceeding and waives any objection to such venue.

24. Financials.

- a. We highly recommend working with a tax professional to see how the federal tax credit applies to your tax situation. Some income and tax situations are ineligible for the tax credit.
- b. You and your financial advisor are solely responsible for determining your actual ROI. Utility rates, utility REC rates (if offered by utility), and tax credits may change, which are outside of our control and liability.
- c. The federal tax credit is currently set to expire on January 1st, 2024 and carryforward may not be allowed thereafter.

25. Entire Agreement This agreement, with exhibits, is the entire agreement between the Parties and supersedes any and all previous agreements that existed or may have existed between the Parties. No term sheet, feasibility report, spreadsheet, pamphlet, or any other document is an agreement between the Parties or a part of this agreement. This agreement may be modified only in writing signed by both Parties.

Signatures: The individuals signing below hereby represent that they are authorized to enter into this Agreement on behalf of the Party for whom they sign.

Buyer(s)

Signature William D. Cook Sr.
Printed William D. Cook Sr.
Date March 18, 2022

Signature Janice Cook
Printed JANICE COOK
Date 3/18/2022

Contractor: Organ Mountain Solar & Electric, Lic: 394801

Signature [Signature]
Printed Phillip Samuel
Date 3/18/2022



ATTACHMENT A

Organ Mountain Solar & Electric, LLC 10 Year WORKMANSHIP LIMITED WARRANTY

1(a). LIMITED WARRANTY. Subject to the limitations and exclusions set forth in Section 1(e) below, Organ Mountain Solar & Electric, hereinafter referred to as the "Company" warrants to Client for a period of ten (10) years following the Substantial Completion Date (the "Warranty Period") that the System: (A) was installed (i) in compliance with all applicable codes and regulations in effect at the time of installation; (ii) in accordance with the reasonable industry practices at the time of installation and installed in accordance with the specifications of the Original Equipment Manufacturers ("OEM") specifications of the instruction manuals of the components of the System (each such manufacturer an OEM); and (iii) in a good and workmanlike manner; and (B) will be free from material defects in assembly and installation techniques that would result in the System failing to perform in accordance with the specifications.

1(b). TELEPHONE SUPPORT. Client will be entitled to reasonable telephone assistance from the Company.

1(c). CLAIMS. Client shall make all warranty claims in writing to the Company prior to the expiration of the Warranty Period. If the Client has a valid warranty claim, subject to the limitations and exclusions set forth in Section 1(e) below, the Company, at its sole discretion, will either: (A) repair, correct or otherwise cure, or subcontract or otherwise arrange for a third party to repair, correct or otherwise cure, the defect in assembly or installation; or (B) pay to Client the reasonable cost of repairing, correcting or curing the defect in assembly or installation; or (C) Pay Client prorated portion of the system that is not performing.

1(d). WARRANTY EXCLUSIONS. Notwithstanding anything to the contrary set forth herein, the Company specifically excludes from the limited warranty set forth in Section 1(a) above any defects caused by or resulting from any of the following: (A) If the System is installed on the ground, defects caused by soil movement or erosion; (B) defects for which compensation is provided by State or Federal statutes or mandate or is covered by other insurance; (C) Defects caused or made worse by: (i) materials, equipment or work supplied by any third party, including any OEM; (ii) misuse, abuse, negligence, accident, vandalism, theft, terrorism or unauthorized tampering with the System by any party other than the Company; (iii) negligence, improper maintenance or improper operation of the System by anyone other than the Company; or (iv) normal wear and tear or deterioration. (D) Loss or damage to the System that results from acts of God or acts of force majeure, including without limitation, fire, explosion, smoke, water escape, changes which are not reasonably foreseeable in the level of underground water table, wind, hail, lightning, falling trees, animals, vehicles, flood, earthquake and climate change. (E) Damage to structure of any building or any personal property located on the Site caused by snow runoff over the panels. (F) Damage to the System resulting from animals. (G) Damage to structure of any building or any personal property located on the Site caused by roof leaks. Client hereby acknowledges and agrees that installation of the System may involve penetration of the roof and the Company specifically disclaims any liability related thereto unless the same results directly and completely from the Company's defective installation of the System within 1 year of the penetration. (H) Failure of data monitoring system due to the failure of communications equipment connected to the client's internet. It is the client's responsibility to monitor their output and notify the Company in writing about output losses that might give rise to a warranty claim. Production estimates are estimates only and may vary due to weather, excessive snow or soiling, increased shading from foliage, etc. Initial (Year 1) production will be accurate to within 10% of the estimated production, except where weather, excessive shading or other natural phenomena outside of Company's control impacts the production.

1(e). THIS WARRANTY IS A LIMITED WARRANTY AND IS GIVEN IN LIEU OF AND INCLUDES ANY

AND ALL EXPRESS AND IMPLIED WARRANTIES THAT MAY APPLY TO THE INSTALLATION OF THE SYSTEM. THE COMPANY MAKES NO OTHER REPRESENTATIONS OR WARRANTIES OF ANY KIND, WHETHER EXPRESS OR IMPLIED, REGARDING ANY ASPECT OF INSTALLATION OR OTHERWISE COVERING THE SYSTEM OR ANY COMPONENT OR ELEMENT THEREOF, INCLUDING WITHOUT LIMITATION, THE MERCHANTABILITY, SUITABILITY, ORIGINALITY, FITNESS FOR A PARTICULAR USE OR PURPOSE OR RESULTS TO BE DERIVED FROM THE USE OF THE SAME, AND THE COMPANY SPECIFICALLY DISCLAIMS ALL SUCH IMPLIED WARRANTIES.

2 THIRD PARTY WARRANTIES. (A) the Company hereby assigns to Client all warranties made by third parties, including any applicable OEM and/or subcontractor, with respect to all System Components, module mounting systems and subcontractor services, if any, (collectively, the "Third Party Warranties"). Client acknowledges that: (i) the Company will have no liability or responsibility for honoring any such Third Party Warranties; and (ii) Client will be solely responsible for knowing the terms and conditions of any such Third Party Warranties and enforcing the same. (B) Upon Client's reasonable request, the Company will use commercially reasonable efforts to assist Client in connection with enforcing all Third-Party Warranties. (C) In some cases, OEM warranty may not include labor or travel and the client would be responsible for those costs.

Initial Here: bc jc



Organ Mountain Solar & Electric
 400 S Compress Rd Suite D, Las Cruces, NM 88005
 (575) 288-1792
 License # 394801

ATTACHMENT B: Distributed Generation Disclosure Statement

I. Party Information				
<p><u>Purchaser</u> Name: The Potteries Bill and Janice Cook Address: 2260 Calle De Santiago Mesilla, NM 88046 Telephone: (575) 202-8794</p>	<p><u>Seller, Installer and Maintenance Provider</u> Name: Organ Mountain Solar & Electric Address: 400 S Compress Rd Suite D Las Cruces, NM 88005 Telephone: (575) 288-1792 Email: pmle@omsande.com License No: 394801 Organ Mountain Solar & Electric is a licensed and insured electrical contractor.</p>			
II. Purchase Price, Financing and Payments				
<p>A. Purchase Price of the Distributed Energy System: \$9,430.00</p>				
<p>Paid as follows:</p>				
#	Event	Description	Portion	Amount
1	Project Closing	Engineering payment due at contract signing	\$2,000.00	\$2,000.00
2	Equipment Acquisition	Invoice sent 45 days prior to scheduled installation Date	32.21 % of Balance	\$2,715.00
3	Installation Date	Invoice sent on installation date	32.21 % of Balance	\$2,715.00
4	System Activation	Invoice sent for outstanding balance upon system activation	Balance	\$2,000.00
Contract Cost				\$9,430.00
<p>B. Financing Costs: N/A</p>				
<p>NOTE: YOU ARE PURCHASING THIS SOLAR SYSTEM; YOU OWN THE SYSTEM AND THE POWER GENERATED BY THE SYSTEM.</p>				

Distributed Generation Disclosure Statement

This Distributed Generation Disclosure Statement is supplied to the consumer pursuant to direction of the State of New Mexico Distributed Generation Disclosure Act (2017). It references certain provisions of the proposed or mutually executed "RESIDENTIAL DESIGN AND INSTALLATION CONTRACT", between consumer and Organ Mountain Solar & Electric, Inc.

III. Fees
<p>A. <u>Late Fees. Late payments will accrue 5% annual interest.</u></p> <p>B. <u>System Removal Fees. Should you desire to have your system removed from your roof, Organ Mountain Solar & Electric will provide a quotation.</u></p> <p>C. <u>Uniform Commercial Code Notice Removal and Refiling Fees. NONE.</u></p> <p>D. <u>Maintenance Fees. Should your system require maintenance that is not covered under our workmanship warranties or equipment warranties, service work will be charged at time and materials rates effective at the time of service. Internet Connection Fees: None if Owner provided internet available.</u></p> <p>E. <u>Automated Clearing House Fees. NONE.</u></p> <p>F. <u>(List one-time or recurring fees). NONE.</u></p>
<p>Consult with your tax professional to determine the value to you of incentives and cost to you of any tax obligations.</p>
IV. Tax Credits, Rebates and incentives and Renewable Energy Certificates. The distributed energy system is eligible for the tax benefits and incentives listed below. Values are estimates. Verify with your tax professional.
<p>A. <u>Federal Investment Tax Credit is owned by the system purchaser (estimated): \$2,451.80</u></p> <p>B. <u>Solar arrays installed on commercial properties are eligible for MACRS Depreciation. This tax incentive is owned by the system purchaser. The exact value of this incentive depends upon your tax rate. \$2,712.59</u></p> <p>C. <u>Renewable Energy Certificates (RECs). The system purchaser owns any proceeds from the sale of RECs, if any, from this solar system.</u></p>

Distributed Generation Disclosure Statement

V. Tax Obligations - You are required to pay the the following tax obligations.

- A. Business Personal Property Taxes. \$0.00
- B. Gross Receipts Taxes. None.
- C. In the case of a commercial installation, the system purchaser is responsible to pay any change in assessed property taxes. Estimated cost is \$0.00

VI. Transferability of Lease or PPA and the Selling or Refinancing your Home.

- A. In the event of the transfer of the real property to which the distributed energy generation system is affixed, the Buyer has the following options:
Once the system is purchased from the solar company, the solar company has no constraints on the transfer of ownership of the solar system. Any constraints associated with third-party financing are according to terms of that agreement between the solar system owner and the third-party financing company.
- B. Transfer of Warranty: All warranty rights are transferred to the owner. Manufacturers may have conditions on ownership transfers.

VII. Design Assumptions.

- A. System Size: 2.220 DC kW (STC)
- B. Estimated first-year production: 4,102 kWh
- C. Maximum degradation rate: Refer to system module manufacturer's warranty for specific details
- D. Degradation over 25 Years: Refer to system module manufacturer's warranty for specific details

VIII. Financial and Energy Savings Assumptions, Calculations and Comparative

- A. Commercial - Small, Below 15 kW (3)
- B. Utility Rate Class: Commercial - Small, Below 15 kW (3)
- C. Utility Rate Escalation: 4.0 % per year
- D. Payment for excess generation: \$0.01 per kWh

IX. Rates Disclosure

Actual utility rates may increase or decrease and actual savings may vary. For further information regarding rates, you may contact the local utility or the Public Regulation Commission. Tax and other state and federal incentives are subject to change.

Distributed Generation Disclosure Statement

X. Interconnection Disclosure	
Interconnection requirements, including timelines, are established by rules of the Public Regulation Commission and may be obtained from either the Public Regulation Commission or the local utility.	
XI. Permits and Inspections	
Within thirty days of completion of installation or modification, the seller or marketer shall provide the buyer with proof that: <ol style="list-style-type: none"> 1. all required permits for the installation or any modification of the system were obtained prior to installation; and 2. the system received was approved by an authorized inspector. 	
XII. Security Filings	
Seller or Marketer WILL <input type="checkbox"/> WILL NOT <input checked="" type="checkbox"/> place a lien on your home. The contract referenced herein is not a lease or PPA.	
Seller or Marketer WILL <input type="checkbox"/> WILL NOT <input checked="" type="checkbox"/> file a fixture filing or UCC-I Financing Statement with the County Clerk in your home's Real Property Records.	
If the Seller or Marketer filed a fixture filing or UCC-I Financing Statement pursuant to the Uniform Commercial Code they must provide you a copy of the filed financing statement within thirty calendar days of the filing.	
You have the right to cancel your solar contract for a period of <u>3</u> days after the agreement is signed.	
<p>Date: <u>3/18/2022</u></p> <hr/> <p>(Buyer) <i>Janice Cook</i> <i>Phillip D. Cook</i> Printed Name: The Potteries Bill and Janice Cook Address: 2260 Calle De Santiago, Mesilla, NM, 88046 Telephone: (575) 202-8794</p>	<p>This Document was prepared by:</p> <p>Salesperson Name: Phillip Samuel Company: Organ Mountain Solar & Electric Address: 400 S Compress Rd Suite D, Las Cruces, NM, 88005 Telephone: (575) 496-9169 Email: phillip@omsande.com</p> <p><i>Phillip Samuel</i> 3/18/2022</p>



ATTACHMENT C: UTILITY INTERCONNECTION APPLICATION & DATA USAGE AUTHORIZATION

I/We authorize Organ Mountain Solar & Electric to submit the online interconnection application for my/our customer-owned generating facility on my/our behalf.

I/We authorize Organ Mountain Solar & Electric to work with my utility company to collect usage and rate plan information for my property in order to pursue a solar electric proposal.

CUSTOMER SIGNATURE(S)

Signed: William D. Cook Jr.
Name: William D. Cook Jr.
Date: March 18, 2022

Signed: Janice Cook
Name: JANICE COOK
Date: 3/18/2022

BOARD ACTION FORM

AGENDA DATE

PZHAC: June 6, 2022,

BOT:

ITEM: PZHAC Case #061385 – 2872 Calle San Albino submitted by Jeffry & Amanda Buras to repaint house exterior a different color current color is white. **Zoned: Historical (HR)**

BACKGROUND AND ANALYSIS: This case was reviewed by the Architectural Styles Committee (ASC) proposed work involves repainting the dwelling with approved color from color wheel “Hopsack” current color is white.

IMPACT:

- The PZHAC has jurisdiction to recommend approval of the applicant’s request for approval of this request to the BOT.
- The applicant has the authority to make an application request to the PZHAC and BOT.
- Due process was provided to the applicant.

Specific findings of fact:

- The proposed work is on applicant’s property and not in Town of Mesilla right-of-way.

ALTERNATIVES:

The Planning, Zoning and Historical Appropriateness Commission (PZHAC) may:

1. Recommend approval of this case with findings stated above.
2. Recommend approval of this case with findings stated above and conditions.
3. Deny the application.

DEPARTMENT RECOMMENDATIONS:

SUPPORTING INFORMATION:

- Application
- Plans

TOWN OF MESILLA
ZONING APPROVAL

OFFICIAL USE ONLY:
Case # 06/385
Fee \$ 68.00

PERMISSION TO CONDUCT WORK
OR
OBTAIN A COMMERCIAL/RESIDENTIAL BUILDING PERMIT FROM CID

2231 Avenida de Mesilla, P.O. Box 10, Mesilla, NM 88046 (575) 524-3262 ext. 104

CASE NO. _____ ZONE: _____ CODE: _____ APPLICATION DATE: _____

Jeffrey or Amanda Buras _____ 281-221-2797 _____
Name of Property Owner _____ Property Owner's Telephone Number _____
Box 980 _____ Mesilla _____ NM _____ 88046 _____
Property Owner's Mailing Address _____ City _____ State _____ Zip Code _____
jeffrey@jburas.com _____
Property Owner's E-mail Address _____

Self _____
Contractor's Name & Address (If none, indicate Self) _____

Contractor's Telephone Number _____ Contractor's Tax ID Number _____ Contractor's License Number _____

Address of Proposed Work: 2872 Calle De San Albino _____

Description of Proposed Work: _____
Repair stucco and paint building - color sample included. _____

\$ 1000 _____
Estimated Cost _____ Signature of Applicant _____ Date 5/10/22 _____

Signature of property owner: _____

With the exception of administrative approvals, all permit requests must undergo a review process from staff, PZHAC and/or BOT before issuance of a zoning permit. Plan sheets are to be no larger than 11 x 17 inches or shall be submitted electronically.

FOR OFFICIAL USE ONLY

PZHAC Administrative Approval BOT Approved Date: _____
 Approved Date: _____ Disapproved Date: _____
 Disapproved Date: _____ Approved with Conditions
 Approved with conditions

PZHAC APPROVAL REQUIRED: ___ YES ___ NO BOT APPROVAL REQUIRED: ___ YES ___ NO

CID PERMIT/INSPECTION REQUIRED: ___ YES ___ NO ___ SEE CONDITIONS

CONDITIONS: _____

PERMISSION ISSUED/DENIED BY: _____ ISSUE DATE: _____

THIS APPLICATION SHALL INCLUDE ALL OF THE FOLLOWING:

1. _____ Plot plan with legal description to show existing structures, adjoining streets, driveway(s), improvements & setbacks. Verification shall show that the lot was LEGALLY subdivided through the Town of Mesilla or that the lot has been in existence prior to February 1972.
2. _____ Site Plan with dimensions and details.
3. _____ Foundation plan with details.
4. _____ Floor plan showing rooms, their uses and dimensions.
5. _____ Cross section of walls
6. _____ Roof and floor framing plan
8. _____ Proof of legal access to the property.
9. _____ Drainage plan.
10. _____ Details of architectural style and color scheme (checklist included for Historical zones) – diagrams and elevations.
11. _____ Proof of sewer service or a copy of septic tank permit; proof of water service (well permit or statement from the Public Utility providing water services).
12. _____ Proof of legal access to the property.
13. _____ Other information as necessary or required by the City Code or Community Development Department (See other side.)

2878 Calle De San Albino



ACCOUNTNUMBER:	R0400667	PARCELNUMBER:	4006138343035
OWNERNAME:	BURAS JEFFREY	MAILADDR1:	1844 L STREET NE
CITY:	WASHINGTON	STATE:	DC
ZIP:	20002	LOT:	
BLOCK:		SUBNAME:	
TRS:	235 1E 36	SITUSADDRS:	2878 CALLE DE SAN ALBINO
TOTALACRES:	0		

- [Account Search](#)
- [View Created Report\(s\)](#)
- [Help?](#)
- [Logout Public](#)

Account: R0400667 Real Property Account *Mill Levy does not include Special District Rates such as: Lower Rio Grande Flood Levy, Hueco Levy, Mclead Watershed Levy, Caballo Soil and Water Conservation Levy, and La Union Watershed Levy.







3003-10B
Hopsack

BOARD ACTION FORM

AGENDA DATE

PZHAC: June 6, 2022,

BOT:

ITEM: PZHAC Case #061387 – 2060 Calle de Parian Submitted by Julienne Hadfield to patch, repair and repaint windows and door no color change. Zoned: **Historical Residential (HR)**

BACKGROUND AND ANALYSIS: This case was reviewed by the Architectural Styles Committee (ASC) proposed work involves removing cracked weathered paint, patch and repaint door and windows with the same color.

IMPACT:

- The PZHAC has jurisdiction to recommend approval of the applicant's request for approval of this request to the BOT.
- The applicant has the authority to make an application request to the PZHAC and BOT.
- Due process was provided to the applicant.

Specific findings of fact:

- The proposed work is on applicant's property and not in Town of Mesilla right-of-way.

ALTERNATIVES:

The Planning, Zoning and Historical Appropriateness Commission (PZHAC) may:

1. Recommend approval of this case with findings stated above.
2. Recommend approval of this case with findings stated above and conditions.
3. Deny the application.

DEPARTMENT RECOMMENDATIONS:

SUPPORTING INFORMATION:

- Application
- Plans

**TOWN OF MESILLA
ZONING APPROVAL**

OFFICIAL USE ONLY:
Case # 061387
Fee \$ 44.00

**PERMISSION TO CONDUCT WORK
OR
OBTAIN A COMMERCIAL/RESIDENTIAL BUILDING PERMIT FROM CID**

2231 Avenida de Mesilla, P.O. Box 10, Mesilla, NM 88046 (575) 524-3262 ext. 104

CASE NO. _____ ZONE: _____ CODE: _____ APPLICATION DATE: 5/20/22

Name of Property Owner: Julienne Hadfield Property Owner's Telephone Number: 575-202-8931
Property Owner's Mailing Address: 5011 Wildhorse L.C. City: N.M. State: N.M. Zip Code: 88011

Property Owner's E-mail Address: _____

Contractor's Name & Address (If none, indicate Self): _____

Contractor's Telephone Number: 575-642-5642 Contractor's Tax ID Number: 01-154497-000 Contractor's License Number: 19662

Address of Proposed Work: 20600 Calle de Parlan, Mesilla, N.M. 88316

Description of Proposed Work: Patch + Repair of windows and doors. Paint is old + peeling. Some color as current color pictured and attached to this application. Handed in to town of Mesilla 5-20-22

Estimated Cost: \$ 800. Signature of Applicant: _____ Date: 5-19-22

Signature of property owner: _____

copied for Julienne + for Mar

With the exception of administrative approvals, all permit requests must undergo a review process from staff, PZHAC and/or BOT before issuance of a zoning permit. Plan sheets are to be no larger than 11 x 17 inches or shall be submitted electronically.

FOR OFFICIAL USE ONLY

PZHAC Administrative Approval **BOT** Approved Date: _____
 Approved Date: _____ Disapproved Date: _____
 Disapproved Date: _____ Approved with Conditions
 Approved with conditions

PZHAC APPROVAL REQUIRED: YES NO BOT APPROVAL REQUIRED: YES NO

CID PERMIT/INSPECTION REQUIRED: YES NO SEE CONDITIONS

CONDITIONS: _____

PERMISSION ISSUED/DENIED BY: _____ ISSUE DATE: _____

THIS APPLICATION SHALL INCLUDE ALL OF THE FOLLOWING:

1. _____ Plot plan with legal description to show existing structures, adjoining streets, driveway(s), improvements & setbacks. Verification shall show that the lot was **LEGALLY** subdivided through the Town of Mesilla or that the lot has been in existence prior to February 1972.
2. _____ Site Plan with dimensions and details.
3. _____ Foundation plan with details.
4. _____ Floor plan showing rooms, their uses and dimensions.
5. _____ Cross section of walls
6. _____ Roof and floor framing plan
8. _____ Proof of legal access to the property.
9. _____ Drainage plan.
10. _____ Details of architectural style and color scheme (checklist included for Historical zones) – diagrams and elevations.
11. _____ Proof of sewer service or a copy of septic tank permit; proof of water service (well permit or statement from the Public Utility providing water services).
12. _____ Proof of legal access to the property.
13. _____ Other information as necessary or required by the City Code or Community Development Department (See other side.)

The following are requirements to be included with all building permit applications for new structures or additions to existing structures, as well as other construction or fixtures that will be permanent in nature and affect the appearance or use of the property. (This includes fences, well houses, storage units, metal sheds, photo-voltaic panels that can be seen from the ground, etc.)

BUILDING PERMIT REQUIREMENTS

A. Completed application, including:

1. Applicant's name ✓
2. Applicant/property owners contact information ✓
3. Physical address of property ✓
4. Description of work to be done, including dimensions of any construction or repairs ✓
5. Value of work to be done ✓
6. Property owner's signature on the application ✓

B. Include all information required in the checklist at the bottom of the application.

C. Additional information required:

please let us know if anything needed before meeting! we will happy to comply 😊

Juliana



Parcel:R0400335

Account: R0400335
 Owner: APPALOOSA LIMITED LLC
 Mail: 5011 WILD HORSE ROAD
 City: LAS CRUCES
 State: NM
 Zip: 88011
 Parcel Address: 2000 CALLE DE PARIAN
 Acres: 0.00

[Assessor's Detailed Parcel Information](#)

[Zoom to](#)

0 20 40ft

-106.795 32.274 Degrees

Town of Mesquite
COP4





BOARD ACTION FORM

AGENDA DATE

PZHAC: June 6, 2022,

BOT:

ITEM: PZHAC **BL #0986** – 1395 Snow Rd. submitted by Eric Madrid of Highcienda Growers for a Cannabis license. Zoned: **Rural Farm (RF)**

BACKGROUND AND ANALYSIS: The applicant proposes to open a business to grow cannabis at the following location. This application falls under the new ordinance just passed by the Board of Trustees on December 30, 2021, and went into effect on January 4, 2022.

IMPACT:

- The PZHAC has jurisdiction to recommend approval of the applicant’s request for approval of this request to the BOT.
- The applicant has the authority to make an application request to the PZHAC and BOT.
- Due process was provided to the applicant.

Specific findings of fact:

- The proposed work is on applicant’s property and not in Town of Mesilla right-of-way.

ALTERNATIVES:

The Planning, Zoning and Historical Appropriateness Commission (PZHAC) may:

1. Recommend approval of this case with findings stated above.
2. Recommend approval of this case with findings stated above and conditions.
3. Deny the application.

DEPARTMENT RECOMMENDATIONS:

SUPPORTING INFORMATION:

- Application
- Plans

Print

**TOWN OF MESILLA
CANNABIS LICENSE
APPLICATION**

2231 Avenida de Mesilla, P.O. Box 10, Mesilla, NM 88046 (575) 524-3262

0986

PLEASE INCLUDE A COPY OF YOUR CURRENT STATE CANNABIS LICENSE, IF NOT LICENSED, A COPY OF YOUR COMPLETE APPLICATION TO THE STATE OF NEW MEXICO, WITH YOUR APPLICATION. FEE DUE: \$250.00. A COPY OF YOUR ISSUED LICENSE FROM THE STATE MUST BE ON FILE PRIOR TO OPERATING.

New Application

Renewal

Highcienda Growers LLC

Business Name

1395 Snow Rd Las Cruces NM 88005

Physical Address

City

State

Zip Code

Eric Madrid

Owner's Name

4531 Alamo Canyon Cir Las Cruces NM 88012

Mailing Address

City

State

Zip Code

575-494-2997

N/A

Owner's Telephone/Cell Number

State License Number

By signing below, you acknowledge the Town's Cannabis Ordinance and NM State Laws and will follow them to the best of your ability.

Signed: [Signature]

Date: 5-13-22

Please return this completed form to:

Town of Mesilla
Attn: Cannabis Licensing
2231 Avenida de Mesilla
P.O. Box 10
Mesilla, NM 88046

Once this form, \$250.00 fee, and the required documentation has been received, you will be issued a current license by the Town of Mesilla. This license shall be renewed annually no later than June 30.

****Both a cannabis license and a business license are required to do business within the Town of Mesilla limits.****

FOR OFFICIAL USE ONLY

Date Received: 5-13-2022

Receipt #: 00181295

OFFICIAL USE ONLY:

Code 101 #10-43060

Fee \$ 250

Received by: _____

HIGHCIENDA GROWERS LLC
4531 ALAMO CANYON CIR
LAS CRUCES, NM 88012-5125

May 13, 2022
NM Business Tax ID:
03-587860-00-6
Letter ID: L0520148912

STATE OF NEW MEXICO TAXATION AND REVENUE DEPARTMENT
REGISTRATION CERTIFICATE

Date ID Issued 01-Jun-2022	IDENTIFICATION NUMBER 03587860006-GRT	Business Start Date 01-Jun-2022
Business Location 1395 SNOW RD	Business End Date	
City and State LAS CRUCES, NM	Zip Code 88005-3940	
Taxpayer Name HIGHCIENDA GROWERS LLC	Taxpayer Type LLC	
Firm Name HIGHCIENDA GROWERS LLC	Filing Frequency Monthly	
Mailing Address 4531 ALAMO CANYON CIR		
City and State LAS CRUCES, NM	Zip Code 88012-5125	

This Registration Certificate is issued pursuant to Section 7-1-12 NMSA 1978 for Gross Receipts, County Gross Receipts, and Municipal Gross Receipts Taxes. This copy must be displayed conspicuously in the place of business. Any purchaser of the registrants business is subject to certain requirements under Section 7-1-61 NMSA 1978.

Cabinet Secretary

By 

Any inquiries concerning your Identification Number should be addressed to the Audit & Compliance Division, P.O. Box 630, Santa Fe, New Mexico 87504-0630

Form Revised 02/2003

THIS CERTIFICATE IS NOT TRANSFERABLE

STATE OF NEW MEXICO TAXATION AND REVENUE DEPARTMENT
REGISTRATION CERTIFICATE

Date ID Issued 01-Jun-2022	IDENTIFICATION NUMBER 03587860006-GRT	Business Start Date 01-Jun-2022
Business Location 1395 SNOW RD	Business End Date	
City and State LAS CRUCES, NM	Zip Code 88005-3940	
Taxpayer Name HIGHCIENDA GROWERS LLC	Taxpayer Type LLC	
Firm Name HIGHCIENDA GROWERS LLC	Filing Frequency Monthly	
Mailing Address 4531 ALAMO CANYON CIR		
City and State LAS CRUCES, NM	Zip Code 88012-5125	

This Registration Certificate is issued pursuant to Section 7-1-12 NMSA 1978 for Gross Receipts, County Gross Receipts, and Municipal Gross Receipts Taxes. This copy must be displayed conspicuously in the place of business. Any purchaser of the registrants business is subject to certain requirements under Section 7-1-61 NMSA 1978.

Cabinet Secretary

By 

Any inquiries concerning your Identification Number should be addressed to the Audit & Compliance Division, P.O. Box 630, Santa Fe, New Mexico 87504-0630

Form Revised 02/2003

THIS CERTIFICATE IS NOT TRANSFERABLE

This digital copy of your license is to be used for limited purposes only and does not replace the official license issued and mailed by the New Mexico Regulation and Licensing Department. This digital copy may be used for insurance credentialing or for other limited purposes when an official license is not available. This digital copy should not be used for public display, except for temporary purposes, if the license is required to be displayed at the licensee's primary place of business. Additional copies or replacements of an official license may be ordered for a fee online through the licensing portal.



State of New Mexico

**Regulation & Licensing Department
Cannabis Control Division**

HEREBY CERTIFIES THAT

Highcienda Growers LLC

HAVING GIVEN SATISFACTORY EVIDENCE OF THE LICENSING REQUIREMENTS
PRESCRIBED BY LAW IS GRANTED A LICENSE TO OPERATE IN THE STATE
OF NEW MEXICO AS A

Cannabis Producer

License No. CCD-2022-0451-001

Issued 05/26/2022

Expires 05/26/2023

THIS LICENSE SHOULD BE CONSPICUOUSLY POSTED IN PLACE OF BUSINESS OR AS REQUIRED BY LAW



[Home\(/bcd/s/\)](#) License ▼ [Search License\(/bcd/s/public-search-license-division\)](#)

Licenses & Applications

My Applications

Application ID	License Type	Application Type	Applied Date	Status	Action	Issuance
PAR-0000019696	Cannabis Producer	New	4/25/2022	Submitted	View	

[View All](#)

Boards and Commissions Division

[Apply for a License](#)

Cannabis Control Division

[Apply for a License](#)

Cannabis Control Division



[Home\(/bcd/s/\)](#) [License](#) ▼ [Search License\(/bcd/s/public-search-license-division\)](#)



Checking Candidacy

Checking Candidacy

Are you only producing medical-use cannabis?

Yes No

[Cancel](#)



[Home\(/bcd/s/\)](#) [License](#) ▼ [Search License\(/bcd/s/public-search-license-division\)](#)



Primary Business Contact Information

Primary Business Contact Information

Primary Physical Address

Address 1

Address 2

City

State

Zip Code

Business Legal Name

Doing Business As (DBA)

Type of Business

FEIN/SSN

County where Primary Business is Located

Dona Ana

Business Website

Previous

Next

Cancel



Home(/bcd/s/) License ▾ Search License(/bcd/s/public-search-license-division)



Social and Economic Equity Plan

Social and Economic Equity Plan

Please provide the applicant's social and economic equity plan, which should describe the applicant's plan to encourage economic and social diversity in employment. The applicant's plan should include race, ethnicity, gender, age, and residential status of the licensee, all controlling persons and employees of the applicant and whether the applicant, controlling persons, employees or the locations where the cannabis products are produced are located in an underserved rural community, including tribal, acequia, land grant-merced, federally designated opportunity zone, or other rural historic communities.

Business Legal Name	Uploaded files for Social and Economic Equity Plan.
Highcienda Growers LLC	Social and Economic Equity Plan (4)

Previous

Save & Next

Cancel



[Home\(/bcd/s/\)](#) [License](#) [Search License\(/bcd/s/public-search-license-division\)](#)

-
-
-
-
-
-
-
-

Ownership - Controlling Person(s)

Ownership - Controlling Person(s)

Cannabis Regulation Act Section 2 (U.) "controlling person":
(1) means a person that controls a financial or voting interest of ten percent or more of, or an officer or board member of, a cannabis establishment; and
(2) does not include a bank or licensed lending institution.

Business Controlling Person

Is the applicant a controlling person of this cannabis business?

Pronoun	First Name	Last Name
<input type="text" value="He"/>	<input type="text" value="Eric"/>	<input type="text" value="Madrid"/>

Phone Number

Email Address

Date of Birth

Mailing Address

Address 1

Address 2

City

Las Cruces

State

NM

Zip Code

88012

Are you a New Mexico resident?

Yes

Ethnicity

Hispanic, Latino, or Spanish origin

Race

White

Gender

Male

Has this person ever legally changed their name or used a different name for employment or school?

No

Has this partner of your limited partnership, this member of your limited liability company, this director, officer, or trustee of your corporation or trust, or this controlling person of the applicant been convicted of the following crimes:

- A felony conviction involving fraud, deceit, or embezzlement
- A felony conviction for hiring, employing, or otherwise using a person younger than eighteen years of age to:
 - Prepare for sale, transport or carry a controlled substance; or,
 - Sell, give away or offer to sell a controlled substance to any person
- A felony offense for the possession, use, manufacture, distribution or dispensing or possession with the intent to manufacture, distribute or dispense a controlled substance, which no longer includes cannabis.

No

Is the applicant the sole controlling person of the cannabis business?

Yes

Previous

Next

Cancel



[Home\(/bcd/s/\)](#) [License](#) ▼ [Search License\(/bcd/s/public-search-license-division\)](#)



Ownership Document Upload

Ownership Document Upload

You need to upload proof that the applicant and each controlling person is at least 21 years of age. Proof of age includes identification issued by a federal or state government that includes the name, date of birth, and picture of the applicant of the controlling person.

FIRST NAME	LAST NAME	FILES
Eric	Madrid	Eric Madrid NM Drivers License
Previous		
Save & Next		

[Cancel](#)



[Home\(/bcd/s/\)](#) [License](#) [Search License\(/bcd/s/public-search-license-division\)](#)



Premises Details

Premises Details

▼ Premises

Address 1

Address 2

City

State

Zip

Business Hours of Operation

Start Of Day

End Of Day

What is the initial amount of mature cannabis plants you intend to grow?

What is the initial amount of immature cannabis plants you intend to grow?

225

What is the estimated water usage for the entered plant counts? (In Gallons)

153000

Previous

Next

Cancel



Home(/bcd/s/) License ▾ Search License(/bcd/s/public-search-license-division)



Premises Address and Document Upload

Premises Address and Document Upload

For each of the premises you are requesting, please upload the following two (2) documents required for your application.

Please click on each document name to view additional information.

> Demonstration of Water Right

> Water and Energy Use Plan

ADDRESS 1	CITY	FILES
1395 Snow Rd	Las Cruces	The Highcienda Water and Energy Use Plan (1) Proof of Water Rights and Ownership

Previous

Save & Next

Cancel



Home(/bcd/s/) License ▾ Search License(/bcd/s/public-search-license-division)



Applicant/Business Certifications & Attestations

Applicant/Business Certifications & Attestations

1) I consent to undergo a national criminal history background check and department of public safety (DPS) statewide criminal history screening background check. I understand for purposes of this rule, background checks shall be required for: (1) each partner of a limited partnership; (2) each member of a limited liability company; (3) each director, officer, or trustee of a corporation or trust; and (4) any controlling person of the applicant.

2) I certify I will adhere to production requirements pursuant to the Cannabis Regulation Act, the Lynn and Erin Compassionate Use Act, and division rules, including creating and maintaining a cultivation plan, and cannabis waste procedures for cannabis or cannabis products.

3) I certify I will adhere to cannabis transport requirements pursuant to the Cannabis Regulation Act, the Lynn and Erin Compassionate Use Act, and division rules, including the transport of unprocessed cannabis or cannabis products to other cannabis establishments.

4) I certify I will adhere to New Mexico department of agriculture (NMDA) pesticide registration, licensing, and use requirements to ensure a safe product and environment.

5) I certify I will adhere to security requirements pursuant to the Cannabis Regulation Act, the Lynn and Erin Compassionate Use Act, and division rules, including requirements relating to safety and security procedures, security devices to be used, placement of security devices, personal safety, and crime prevention techniques.

6) I certify I will adhere to quality assurance requirements pursuant to the Cannabis Regulation Act, the Lynn and Erin Compassionate Use Act, and division rules, including requirements relating to routine testing by a licensed testing laboratory, division inspection of licensed premises during normal business hours, and testing of cannabis.

7) I certify I will adhere to applicable federal, state and local laws governing the protection of public health and the environment, including occupational health and safety, food safety, environmental impacts, natural resource protections, air quality, solid and hazardous waste management, and wastewater discharge.

8) I certify I have never been denied a license or had a license suspended or revoked by the division or any other state cannabis licensing authority or a detailed description of any administrative orders, civil judgements, denial or suspension of a cannabis license, revocation of a cannabis license, or sanctions for unlicensed medical or commercial cannabis activity by any state licensing authority, against the applicant, controlling person, or a business entity in which the applicant or controlling person was a controlling person within the three years immediately preceding the date of the application.

person was a controlling person within the three years immediately preceding the date of the application.

9) I certify that a premises diagram shall be kept at each licensed premises at all times and made available for in person inspection by the Cannabis Control Division or its agents upon request. This premises diagram will conform to the requirements set forth in 16.8.2 NMAC: LICENSING AND OPERATIONAL REQUIREMENTS FOR CANNABIS ESTABLISHMENTS.

10) I certify that that my business is in good standing with the New Mexico Secretary of State, including all documents filed with the New Mexico Secretary of State.

✓ I attest to the following: Under penalty of perjury, I hereby declare that the information contained within and submitted with the application is complete, true and accurate. I understand that a misrepresentation of fact or violation of these rules may result in denial of the license application or revocation of a license issued.

Attestation Signature

Attestation Date



Cancel



New Mexico Office of the State Engineer

Water Right Summary



[get image list](#)

WR File Number: LRG 09909 **Subbasin:** LRN **Cross Reference:** -
Primary Purpose: MUL 72-12-1 MULTIPLE DOMESTIC HOUSEHOLDS
Primary Status: DCL DECLARATION
Total Acres: 0 **Subfile:** - **Header:** -
Total Diversion: 6 **Cause/Case:** -
Owner: OSCAR A LUEVANO
Owner: MARY ANN LUEVANO

Documents on File

Trn #	Doc	File/Act	Status		Transaction Desc.	From/	Acres	Diversion	Consumptive
			1	2		To			
724102	COWNF	2022-04-19	CHG	PRC	LRG 09909	T		0	
405122	COWNF	2008-04-11	CHG	PRC	LRG 09909	T	0	0	
144271	COWNF	1998-02-10	CHG	PRC	LRG 09909	T	0	0	
132991	DCL	1997-10-22	DCL	PRC	LRG 09909	T	0	6	

Current Points of Diversion

(NAD83 UTM in meters)

POD Number	Well Tag	Source	Q	64	Q16	Q4	Sec	Tw	Rng	X	Y	Other Location Desc
LRG 09909		Shallow	3	3	1	26	23S	01E		328661	3572880*	

An () after northing value indicates UTM location was derived from PLSS - see Help

Place of Use

Q	Q	256	64	Q16	Q4	Sec	Tw	Rng	Acres	Diversion	CU	Use	Priority	Status	Other Location Desc
		3	3	1	26	23S	01E		0	6		MUL	06/18/1973	DCL	

Source

Acres	Diversion	CU	Use	Priority	Source Description
0	6		MUL	06/18/1973	GW

The data is furnished by the NMOSE/TSC and is accepted by the recipient with the expressed understanding that the OSE/TSC make no warranties, expressed or implied, concerning the accuracy, completeness, reliability, usability, or suitability for any particular purpose of the data.

4/27/22 1:09 PM

WATER RIGHT
SUMMARY

4-25296
LS

File No.: LRG-9909



NEW MEXICO OFFICE OF THE STATE ENGINEER

CHANGE OF OWNERSHIP OF 72-12-1 PERMIT FOR (check one):



<input checked="" type="checkbox"/> Individual	<input type="checkbox"/> Corporation
<input type="checkbox"/> Trustee	<input type="checkbox"/> Partnership
<input type="checkbox"/> Estate	<input type="checkbox"/> Limited Liability Co.
<input type="checkbox"/> Tribes, Pueblos, Nation	<input type="checkbox"/> Governmental Entity

1. OWNER OF RECORD (Seller)

Name: DANIEL A. ROMANELLI	Name: LAURA C. ROMANELLI
Phone: <input type="checkbox"/> Home <input type="checkbox"/> Cell Phone (Work):	Phone: <input type="checkbox"/> Home <input type="checkbox"/> Cell Phone (Work):
a. Owner of Record File No.: LRG-9909	b. Sub-file No.: c. Cause No.:

2. NEW OWNER (Buyer) Note: If more owners need to be listed, attach a separate sheet. Attached? Yes

Name: OSCAR A. LUEVANO	Name: MARY ANN LUEVANO
Contact or Agent: check here if Agent <input type="checkbox"/>	Contact or Agent: check here if Agent <input type="checkbox"/>
Mailing Address: 1395 SNOW RD	Mailing Address:
City: LAS CRUCES	City:
State: NM Zip Code: 88005	State: Zip Code:
Phone: 575-680-0303 <input type="checkbox"/> Home <input checked="" type="checkbox"/> Cell Phone (Work):	Phone: <input type="checkbox"/> Home <input type="checkbox"/> Cell Phone (Work):
E-mail (optional): Maryann@glitz.edu	E-mail (optional):

RECEIVED
 APR 19 AM 7:01
 LAS CRUCES, NEW MEXICO

Required: Submit warranty deed(s) or other instrument(s) of conveyance properly recorded with the county clerk's office.

3. PURPOSE OF USE & AMOUNT CONVEYED

Check all that apply: <input checked="" type="checkbox"/> Domestic <input type="checkbox"/> Livestock <input type="checkbox"/> Multiple House <input type="checkbox"/> Drinking & Sanitary	Amount of Water (acre-feet per annum):
---	--

4. LIST ALL KNOWN WELLS (POD) FOR THE 72-12-1 PERMIT CONVEYED

OSE POD No.:	Well Tag ID No.: (if applicable)	Subdivision	Section or X (Easting or Longitude)	Township or Y (Northing or Latitude)	Range	County
LRG-9909			20	235	01E	DA

5. CHECK HERE IF WELL IS SHARED BY MULTIPLE HOUSEHOLDS:

Note: Attach an updated list of lots served and owner contact information.

FOR OSE INTERNAL USE		Change of Ownership, Form wr-02d, Rev 10/21/19	
File No.: LRG-9909	Trn. No.: 724102	Well Tag ID No. (if applicable):	
Trans Desc. (optional):		Sub-Basin: LRN	Receipt No.: 4-25296

6. ADDITIONAL STATEMENTS OR EXPLANATIONS

ACKNOWLEDGEMENT FOR INDIVIDUAL

I, We (name of owner(s)), OSCAR B. LUEVANO Mary Ann Luevano
Print Name(s)

affirm that the foregoing statements are true to the best of (my, our) knowledge and belief.

[Signature]
Signature

Mary Ann Luevano
Signature

State of New Mexico,
 County of Dona Ana ss.

This instrument was acknowledged before me this 19th day of April A.D., 2022, by (name of owner(s)):
OSCAR B. LUEVANO AND MARY ANN LUEVANO

Notary Public:
 My commission expires:

[Signature]
 STATE OF NEW MEXICO
 NOTARY PUBLIC
 LILIANA GALLEGOS
 COMMISSION #1127302
 COMMISSION EXPIRES 10/10/2023

ACKNOWLEDGEMENT FOR CORPORATION

I, We (name of owner(s)), _____
Print Name(s)

affirm that the foregoing statements are true to the best of (my, our) knowledge and belief.

Officer Signature

State of _____)
ss.
 County of _____)

Officer Signature

This instrument was acknowledged before me this _____ day of _____ A.D., 20____, by the following on behalf of said corporation.

Name of Officer: _____
 Title of Officer: _____
 Name of Corporation Acknowledging: _____
 State of Corporation: _____

Notary Public: _____
 My commission expires: _____

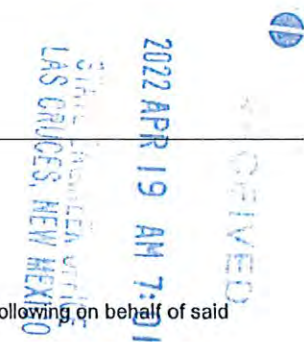

FOR OSE INTERNAL USE

Change of Ownership, Form wr-02d, Rev 10/21/19

File No.: <u>LRG-9909</u>	Trn. No.: <u>724102</u>	Well Tag ID No. (if applicable):
Trans Desc. (optional):	Sub-Basin: <u>LRN</u>	Receipt No.: <u>4-25296</u>

Return to Dona Ana Title Company
File No. 2517309-DA06 SML

WARRANTY DEED (Joint Tenants)

Daniel A. Romanelli and Laura C. Romanelli, husband and wife, for consideration paid, grant(s) to Oscar A. Luevano and Mary Ann Luevano, husband and wife as joint tenants with right of survivorship whose address is 1395 Snow Rd, Mesilla, NM 88046 as joint tenants the following described real estate in Dona Ana County New Mexico:

LOT 1, WIDMOYER TRACTS, IN DONA ANA COUNTY, NEW MEXICO, AS SHOWN AND DESIGNATED ON THE PLAT THEREOF, FILED IN THE OFFICE OF THE COUNTY CLERK OF SAID COUNTY ON DECEMBER 18, 1997, IN BOOK 19 PAGE(S) 35 OF PLAT RECORDS.

Subject to patent reservations, restrictions, and easements of record and taxes for the year 2020 and subsequent years.

with warranty covenants..

WITNESS my/our hand(s) and seal(s) this 13 day of August, 2020.

[Signature]

Daniel A. Romanelli
[Signature]

Laura C. Romanelli

STATE OF NEW MEXICO
COUNTY CLERK
LAS CRUCES, NEW MEXICO

2022 APR 19 AM 7:01

Individual Capacity

State of TEXAS)
County of Hidalgo) §

This instrument was acknowledged before me on the 13th day of August, 2020, by Daniel A. Romanelli and Laura C. Romanelli.

My commission expires: 8/30/2020 *[Signature]*
Notary Public

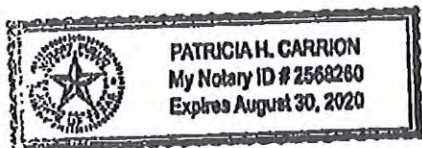

Mike A. Hamman, P.E.
STATE ENGINEER



District 4 Office
1680 Hickory Loop Suite J
Las Cruces, NM 88005-6598
Phone: (575) 524-6161
Fax: (575) 524-6160

STATE OF NEW MEXICO
OFFICE OF THE STATE ENGINEER
Las Cruces Office
1680 HICKORY LOOP, SUITE J
LAS CRUCES, NM 88005

Mike A. Hamman, P.E.
State Engineer

Trn Nbr: 724102
File Nbr: LRG 09909

Apr. 19, 2022

OSCAR A LUEVANO AND MARY ANN LUEVANO
1395 SNOW RD
LAS CRUCES, NM 88005

Greetings:

Enclosed is one original copy of a Change of Ownership of a Water Right submitted to this office for filing. This Change of Ownership is accepted for filing in accordance with Section 72-1-2.1, NMSA 1978 (1996 Supp.), effective May 15, 1996. The acceptance by the State Engineer Office does not constitute validation of the right claimed.

According to Section 72-1-2.1, NMSA 1978 (1996 Supp.), you must record this Change of Ownership with the clerk of the county in which the water is located. The filing shall be public notice of the existence and contents of the instruments so recorded.

Sincerely,

A handwritten signature in blue ink, appearing to read "Liliana Gallegos".

Liliana Gallegos
(575)524-6161

Enclosure

chngowrc

BOARD ACTION FORM

AGENDA DATE

PZHAC: June 6, 2022,

BOT:

ITEM: PZHAC **BL #0987** – 1395 Snow Rd. submitted by Eric Madrid of Highcienda Growers for a business license. Zoned: **Rural Farm (RF)**

BACKGROUND AND ANALYSIS: The applicant proposes to open a business to grow cannabis at the following location. This application falls under the new ordinance just passed by the Board of Trustees on December 30, 2021, and went into effect on January 4, 2022.

IMPACT:

- The PZHAC has jurisdiction to recommend approval of the applicant's request for approval of this request to the BOT.
- The applicant has the authority to make an application request to the PZHAC and BOT.
- Due process was provided to the applicant.

Specific findings of fact:

- The proposed work is on applicant's property and not in Town of Mesilla right-of-way.

ALTERNATIVES:

The Planning, Zoning and Historical Appropriateness Commission (PZHAC) may:

1. Recommend approval of this case with findings stated above.
2. Recommend approval of this case with findings stated above and conditions.
3. Deny the application.

DEPARTMENT RECOMMENDATIONS:

SUPPORTING INFORMATION:

- Application
- Plans



2231 Avenida de Mesilla
P.O. Box 10
Mesilla, NM 88046

Phone: (575) 524-3262 Fax: (575) 541-6327

No.: 0987

Business Registration Application

Please fill out all the information on this form by typing or using blue or black ink. Return update form to the Community Development's Office in person, by email, fax or mail. Please contact us at (575) 524-3262 with any questions. **Note:** A separate business registration application form should be completed for each business location.

Please check one: Business Registration Application Is: New Renewal

Name of Business: Highcienda Growers LLC

Name of Applicant: Eric Madrid

Business Location: 1395 Snow Rd

Mailing Address (Street # or P.O. Box): 4531 Alamo Canyon Cir

E-Mail Address: madrideric23@gmail.com

City: Las Cruces State: NM Zip Code: 88012

Phone # of Business: 575-494-2997

Location of Business: Street 1395 Snow Rd

City: Las Cruces State: NM Zip Code: 88005

PROPERTY INFORMATION

Is property: owned leased

Property Owner: Oscar Luevano, Mary Ann Luevano

Property Owner Address: 3677 Sienna Ave
Las Cruces, NM 88012

Property Owner Phone #: 575-680-0303

Additional Information

Square Footage of Business: 3 Acre Agricultural Land, Barn #1 - 2600 sq. ft., Barn #2 - 576 sq. ft.

Number of Employees: 1-2

Number of Parking Spaces: 6-10

Zoning Code: RF: Rural Farm

Continue to next page>>>>

State or Federal Licensing Information:

If your business requires one of the following Licenses/Permits, you **MUST** submit a copy with your application.

- NM Environment Department Food Permit
- Federal Environmental Protection Agency Permit(s)
- NM Contractor's License
- NM Medical/Pharmaceutical License(s)
- NM Cosmetology/ Barbers License
- NM Real Estate/Broker License
- Well Drillers
- NM Veterinary Medicine
- Federal Firearms License
- Any other License(s)

Pending _____	Pending _____
License #	Expiration Date

Type of business (Please describe product(s) and/or service(s) IF they have changed):

Cannabis producer and manufacturer

Business Owner Is: Sole Proprietorship ___ Partnership ___ Corporation ___ Other LLC

You **MUST** submit a copy of your New Mexico BTIN with your application.

Current New Mexico BTIN #: 0358786006 - CRT

(The location code for reporting earnings received in the Town of Mesilla is **07-303.**)

EMERGENCY CONTACT INFORMATION

Responsible party to be called in case of emergency. Enter name in order of contact (please print):

24 HOUR EMERGENCY PHONE #: 575-494-2997

Name	Telephone #
1. <u>ERIC MARRID</u>	<u>575-494-2997</u>
2. <u>NORMA HERNANDEZ</u>	<u>575-544-7699</u>
3. <u>ELIZABETH TELLES</u>	<u>575-480-440-8507</u>

Do you have an alarm system? Yes No _____

What Type? VIDEO/AUDIO

Which Company, if any, Responds to Alarms? Eagle Security

24-hour video/audio surveillance, 1-5 minute dispatch respond time, full perimeter fencing, advanced locking gates.

By signing this form, I attest that the information I have provided herein is true and accurate to the best of my knowledge. I certify that I am authorized to sign the same as an agent on behalf of the above stated business. I agree to pay all associated fees including: the annual business registration fee and other permit fees as required by the Town of Mesilla. I understand that I must file any changes to my business status, operations, and/or contact information with the Community Development office in a timely manner.

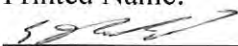
ERIC MARRID
 Printed Name:

 Signature:

5-13-22
 Date:
OWNER
 Title:

Fire Department Inspection Verification

Schedule fire and building inspections AFTER Town staff provides approved application back to you in the following order: 1) Mesilla Fire Marshall's Office (FMO) 575-523-1311. Please retain the Yellow Fire Inspection Report issued by FMO.

A legible copy of the YELLOW Fire Inspection Report issued by FMO, must be returned by the applicant to the Community Development office.

Fire Department Representative Verification: _____

Fire Inspection Date: _____

Approved: Yes _____ **No** _____

HIGHCIENDA GROWERS LLC
4531 ALAMO CANYON CIR
LAS CRUCES, NM 88012-5125

May 13, 2022
NM Business Tax ID:
03-587860-00-6
Letter ID: L0520148912

STATE OF NEW MEXICO TAXATION AND REVENUE DEPARTMENT
REGISTRATION CERTIFICATE

Date ID Issued 01-Jun-2022	IDENTIFICATION NUMBER 03587860006-GRT	Business Start Date 01-Jun-2022
Business Location 1395 SNOW RD	Business End Date	
City and State LAS CRUCES, NM	Zip Code 88005-3940	
Taxpayer Name HIGHCIENDA GROWERS LLC	Taxpayer Type LLC	
Firm Name HIGHCIENDA GROWERS LLC	Filing Frequency Monthly	
Mailing Address 4531 ALAMO CANYON CIR		
City and State LAS CRUCES, NM	Zip Code 88012-5125	

This Registration Certificate is issued pursuant to Section 7-1-12 NMSA 1978 for Gross Receipts, County Gross Receipts, and Municipal Gross Receipts Taxes. This copy must be displayed conspicuously in the place of business. Any purchaser of the registrants business is subject to certain requirements under Section 7-1-61 NMSA 1978.

Cabinet Secretary

By 

Any inquiries concerning your Identification Number should be addressed to the Audit & Compliance Division, P.O. Box 630, Santa Fe, New Mexico 87504-0630

Form Revised 02/2003

THIS CERTIFICATE IS NOT TRANSFERABLE

STATE OF NEW MEXICO TAXATION AND REVENUE DEPARTMENT
REGISTRATION CERTIFICATE

Date ID Issued 01-Jun-2022	IDENTIFICATION NUMBER 03587860006-GRT	Business Start Date 01-Jun-2022
Business Location 1395 SNOW RD	Business End Date	
City and State LAS CRUCES, NM	Zip Code 88005-3940	
Taxpayer Name HIGHCIENDA GROWERS LLC	Taxpayer Type LLC	
Firm Name HIGHCIENDA GROWERS LLC	Filing Frequency Monthly	
Mailing Address 4531 ALAMO CANYON CIR		
City and State LAS CRUCES, NM	Zip Code 88012-5125	

This Registration Certificate is issued pursuant to Section 7-1-12 NMSA 1978 for Gross Receipts, County Gross Receipts, and Municipal Gross Receipts Taxes. This copy must be displayed conspicuously in the place of business. Any purchaser of the registrants business is subject to certain requirements under Section 7-1-61 NMSA 1978.

Cabinet Secretary

By 

Any inquiries concerning your Identification Number should be addressed to the Audit & Compliance Division, P.O. Box 630, Santa Fe, New Mexico 87504-0630

Form Revised 02/2003

THIS CERTIFICATE IS NOT TRANSFERABLE

BOARD ACTION FORM

AGENDA DATE

PZHAC: June 6, 2022,

BOT:

ITEM: PZHAC **BL #0990** – 2710 Boldt St. submitted by Charles McMahon of Chuck McMahon Consulting LLC for a business license. **Zoned: Historical Residential (HR)**

BACKGROUND AND ANALYSIS: The applicant proposes to open a home office consulting business.

IMPACT:

- The PZHAC has jurisdiction to recommend approval of the applicant’s request for approval of this request to the BOT.
- The applicant has the authority to make an application request to the PZHAC and BOT.
- Due process was provided to the applicant.

Specific findings of fact:

- The proposed work is on applicant’s property and not in Town of Mesilla right-of-way.

ALTERNATIVES:

The Planning, Zoning and Historical Appropriateness Commission (PZHAC) may:

1. Recommend approval of this case with findings stated above.
2. Recommend approval of this case with findings stated above and conditions.
3. Deny the application.

DEPARTMENT RECOMMENDATIONS:

SUPPORTING INFORMATION:

- Application
- Plans



2231 Avenida de Mesilla
P.O. Box 10
Mesilla, NM 88046

No.: 0990

Phone: (575) 524-3262 Fax: (575) 541-6327

Business Registration Application

Please fill out all the information on this form by typing or using blue or black ink. Return update form to the Community Development's Office in person, by email, fax or mail. Please contact us at (575) 524-3262 with any questions. **Note:** A separate business registration application form should be completed for each business location.

Please check one: Business Registration Application Is: New Renewal

Name of Business: Chuck McMahon Consulting LLC

Name of Applicant: Charles McMahon

Business Location: Home; 2710 Boldt Street, Las Cruces, NM 88005

Mailing Address (Street # or P.O. Box): 2710 Boldt Street

E-Mail Address: chuckmcmahon10@gmail.com

City: Las Cruces State: NM Zip Code: 88005

Phone # of Business: 575.202.1495

Location of Business: Street Boldt Street

City: Las Cruces State: NM Zip Code: 88005

PROPERTY INFORMATION

Is property: owned leased

Property Owner: Charles and Guenevere McMahon

Property Owner Address: 2710 Boldt Street
Las Cruces, NM 88005

Property Owner Phone #: 575.202.1495

Additional Information

Square Footage of Business: approximately 100 sq. ft.

Number of Employees: one

Number of Parking Spaces: one

Zoning Code: H-R: Historical Residential

Continue to next page>>>>

State or Federal Licensing Information:

If your business requires one of the following Licenses/Permits, you **MUST** submit a copy with your application.

- NM Environment Department Food Permit
- Federal Environmental Protection Agency Permit(s)
- NM Contractor's License
- NM Medical/Pharmaceutical License(s)
- NM Cosmetology/ Barbers License
- NM Real Estate/Broker License
- Well Drillers
- NM Veterinary Medicine
- Federal Firearms License
- Any other License(s)

Not applicable _____

not applicable _____

License #

Expiration Date

Type of business (Please describe product(s) and/or service(s) IF they have changed):

Land use, economic development, management and governmental affairs consulting.

Business Owner Is: Sole Proprietorship ___ Partnership ___ Corporation ___ Other LLC

You MUST submit a copy of your New Mexico BTIN with your application.

Current New Mexico BTIN #: 03587962009-GRT

(The location code for reporting earnings received in the Town of Mesilla is **07-303.**)

EMERGENCY CONTACT INFORMATION

Responsible party to be called in case of emergency. Enter name in order of contact (please print):

24 HOUR EMERGENCY PHONE #: 575.202.1495

- | Name | Telephone # |
|--------------------------------------|-------------|
| 1. <u>Chuck McMahon 575.202.1495</u> | |
| 2. _____ | |
| 3. _____ | |

Do you have an alarm system? Yes No _____

What Type? Fire and Burgler

Which Company, if any, Responds to Alarms? Vivint

By signing this form, I attest that the information I have provided herein is true and accurate to the best of my knowledge. I certify that I am authorized to sign the same as an agent on behalf of the above stated business. I agree to pay all associated fees including: the annual business registration fee and other permit fees as required by the Town of Mesilla. I understand that I must file any changes to my business status, operations, and/or contact information with the Community Development office in a timely manner.

Charles McMahon
Printed Name:

16 May 2022

Date:

Signature:

Owner

Title:

Fire Department Inspection Verification

Schedule fire and building inspections AFTER Town staff provides approved application back to you in the following order: 1) Mesilla Fire Marshall's Office (FMO) 575-523-1311. Please retain the Yellow Fire Inspection Report issued by FMO.

A legible copy of the YELLOW Fire Inspection Report issued by FMO, must be returned by the applicant to the Community Development office.

Fire Department Representative Verification: _____

Fire Inspection Date: _____

Approved: Yes _____ **No** _____



Town of Mesilla, New Mexico

Phone (575) 524-3262

P.O. Box 10

2231 Avenida de Mesilla, Mesilla, NM 88046

HOME OCCUPATION CHECKLIST

Appendix A

Checklist for Compliance with MTC 18.52.030, Home Occupation General Conditions
As a part of your application, first time and renewal, for a home occupation we ask that you acknowledge compliance with the following rules and regulations for home occupations in the town of Mesilla by initialing each requirement and signing the checklist below.

cm Only immediate family members occupying the dwelling shall be engaged in the home occupation.

cm The primary use of the dwelling shall be for residential purposes.

cm Items shall not be displayed on the outside of the dwelling or on the premises of the home occupation.

cm There shall be no change in the outside appearance of the dwelling or the premises.

cm Only products of the home occupation shall be sold from the premises.

cm Only two occupations shall be permitted at a time.

cm All activities shall be conducted indoors. There shall be no direct sale of products off display shelves or racks. Retail sales shall only be conducted if product orders are placed earlier by telephone or fax or electronically.

cm Sales to customers shall be arranged by appointment and scheduled so that not more than one customer vehicle is at the dwelling at any one time except for instructional services.

cm For instructional service home occupations no more than five students shall be at the dwelling at any one time.

cm Only one unlighted sign have a maximum area of one and one-half square feet and identifying the occupant(s) and the home occupation(s) shall be permitted.

cm There shall be no external evidence of the conduct of a home occupation on the premises such as commercial vehicles or outside storage of products, materials or supplies.

cm Company owned vehicles which are three-quarter-ton truck or smaller which are also used for personal transportation purposes shall be exempt from the above condition. No more than one such commercial vehicle shall be parked overnight on the premises of a home occupation.

cm No equipment or process shall be used in a home occupation which creates noise, odor, dust, fumes, vibration, glare, electrical interference or other nuisance detectable on adjacent properties.

cm There shall be no toxic, explosive, highly flammable, combustible, corrosive, radioactive or other restricted materials used or stored on the premises of a home occupation beyond the amount kept at a normal residential dwelling or on hand to operate or maintain equipment permitted by the Uniform Fire Code as adopted by the town of Mesilla.

cm All customer parking shall be off-street parking including parking for those home occupations involving teaching where the maximum number of clients shall be five at any one time.

I hereby state under oath that by initialing each requirement above and signing this checklist below I acknowledge that my proposed home occupation is in compliance with the rules and regulations for home occupations in the town of Mesilla and further I state under oath that my responses are true and valid:

Charles McMahon
Applicant's Name Printed

Applicant's Signature

16 May 2022
Date

Witness

Date



Taxpayer Access Point (TAP)

CHUCK MCMAHON CONSULTING LLC

_*3398

2710 BOLDT ST
LAS CRUCES NM 88005-3876

Welcome, Charles McMahon

You last logged in on Monday, May 16,
2022 11:45:37 AM

[Manage My Profile](#)

Gross Receipts Tax (GRT)

CHUCK MCMAHON CONSULTING LLC
2710 BOLDT ST
LAS CRUCES NM 88005-3876

Account

03587962009-GRT

Balance

\$0.00

- > [Make a Payment](#)
- > [Request a Refund](#)
- > [File, View, or Amend All Returns](#)
- > [More Account Options...](#)



CHUCK MCMAHON CONSULTING LLC
2710 BOLDT ST
LAS CRUCES, NM 88005-3876

May 16, 2022
NM Business Tax ID:
03-587962-00-9
Letter ID: L0241915824

STATE OF NEW MEXICO TAXATION AND REVENUE DEPARTMENT
REGISTRATION CERTIFICATE

Date ID Issued 13-May-2022	IDENTIFICATION NUMBER 03587962009-GRT	Business Start Date 13-May-2022
Business Location 2710 BOLDT ST		Business End Date
City and State LAS CRUCES, NM		Zip Code 88005-3876
Taxpayer Name CHUCK MCMAHON CONSULTING LLC		Taxpayer Type LLC
Firm Name CHUCK MCMAHON CONSULTING LLC		Filing Frequency Quarterly
Mailing Address 2710 BOLDT ST		
City and State LAS CRUCES, NM		Zip Code 88005-3876

Form Revised 02/2003

This Registration Certificate is issued pursuant to Section 7-1-12 NMSA 1978 for Gross Receipts, County Gross Receipts, and Municipal Gross Receipts Taxes. This copy must be displayed conspicuously in the place of business. Any purchaser of the registrants business is subject to certain requirements under Section 7-1-61 NMSA 1978.

Cabinet Secretary

By 

Any inquiries concerning your Identification Number should be addressed to the Audit & Compliance Division, P.O. Box 630, Santa Fe, New Mexico 87504-0630

THIS CERTIFICATE IS NOT TRANSFERABLE

STATE OF NEW MEXICO TAXATION AND REVENUE DEPARTMENT
REGISTRATION CERTIFICATE

Date ID Issued 13-May-2022	IDENTIFICATION NUMBER 03587962009-GRT	Business Start Date 13-May-2022
Business Location 2710 BOLDT ST		Business End Date
City and State LAS CRUCES, NM		Zip Code 88005-3876
Taxpayer Name CHUCK MCMAHON CONSULTING LLC		Taxpayer Type LLC
Firm Name CHUCK MCMAHON CONSULTING LLC		Filing Frequency Quarterly
Mailing Address 2710 BOLDT ST		
City and State LAS CRUCES, NM		Zip Code 88005-3876

Form Revised 02/2003

This Registration Certificate is issued pursuant to Section 7-1-12 NMSA 1978 for Gross Receipts, County Gross Receipts, and Municipal Gross Receipts Taxes. This copy must be displayed conspicuously in the place of business. Any purchaser of the registrants business is subject to certain requirements under Section 7-1-61 NMSA 1978.

Cabinet Secretary

By 

Any inquiries concerning your Identification Number should be addressed to the Audit & Compliance Division, P.O. Box 630, Santa Fe, New Mexico 87504-0630

THIS CERTIFICATE IS NOT TRANSFERABLE

BOARD ACTION FORM

AGENDA DATE

PZHAC: June 6, 2022,

BOT:

ITEM: PZHAC Sign Permit #061391 – 2101 Calle de Parian submitted by Valerie Segovia for Nambe sale sign, Zoned: **Historical Commercial (HC)**

BACKGROUND AND ANALYSIS: The applicant proposes sign for on sale items at Nambe.

IMPACT:

- The PZHAC has jurisdiction to recommend approval of the applicant's request for approval of this request to the BOT.
- The applicant has the authority to make an application request to the PZHAC and BOT.
- Due process was provided to the applicant.

Specific findings of fact:

- The proposed work is on applicant's property and not in Town of Mesilla right-of-way.

ALTERNATIVES:

The Planning, Zoning and Historical Appropriateness Commission (PZHAC) may:

1. Recommend approval of this case with findings stated above.
2. Recommend approval of this case with findings stated above and conditions.
3. Deny the application.

DEPARTMENT RECOMMENDATIONS:

SUPPORTING INFORMATION:

- Application
- Plans



BUSINESS HOURS
MON 7:00 - 10:00
TUE 7:00 - 10:00
WED 7:00 - 10:00
THU 7:00 - 10:00
FRI 7:00 - 10:00
SAT 7:00 - 10:00
SUN 7:00 - 10:00

OPEN



THE BEAN

OF MESILLA

BOARD ACTION FORM

AGENDA DATE

PZHAC: June 6, 2022,

BOT:

ITEM: PZHAC Sign Permit #061390 – 2011 Avenida de Mesilla submitted by Mickey Balderas of The Bean to update Logo sign design attached in packet. Zoned: **Historical Commercial (HC)**

BACKGROUND AND ANALYSIS: The applicant proposes new sign design logo for the business with a temporary banner will be in place till the new sign is complete for installation.

IMPACT:

- The PZHAC has jurisdiction to recommend approval of the applicant's request for approval of this request to the BOT.
- The applicant has the authority to make an application request to the PZHAC and BOT.
- Due process was provided to the applicant.

Specific findings of fact:

- The proposed work is on applicant's property and not in Town of Mesilla right-of-way.

ALTERNATIVES:

The Planning, Zoning and Historical Appropriateness Commission (PZHAC) may:

1. Recommend approval of this case with findings stated above.
2. Recommend approval of this case with findings stated above and conditions.
3. Deny the application.

DEPARTMENT RECOMMENDATIONS:

SUPPORTING INFORMATION:

- Application
- Plans



Town of Mesilla
P.O. BOX 10
MESILLA, NM 88046
PHONE: (575) 524-3262 FAX (575) 541-6327

SIGN PERMIT

Application Date: 04.28.2022

Name' _____
Name of Business

Valerie Segovia _____
Name of Applicant

2109 Calle de Parian _____
Address of Business

2109 Calle de Parian _____
Address of Applicant

Mesilla NM 88046
City State Zip

Mesilla NM 88046
City State Zip

-575-527-4623 _____
Telephone Number

575-644-9260 _____
Alternate Telephone Number

Location and description of Sign:
(include dimensions, lettering, shape, material, texture, colors, and/or finish to be used. Attach a drawing of the location of the sign, including any other advertising structures on the building or lot.)

For Office Use Only

Administrative Approval: _____
PZHAC Approval: _____
BOT Approval: _____

Permit Fee: 0. _____
Date of Payment: _____
CASE NUMBER: 061391





BOARD ACTION FORM

ITEM:

Participation in the 2022-2023 Local Government Road Fund Program (LGRF) and submission of a resolution and interest letter for the LGRF Match Waiver Program.

BACKGROUND:

The Town of Mesilla received a letter from NMDOT dated May 19, 2022 approving the Town's application for the 2022-2023 LGRF Program.

SUPPORTING INFORMATION:

Copy of NMDOT Letter dated May 19, 2022
TOM Match Waiver Resolution
TOM Match Waiver interest letter
TOM LGRF Resolution

BOT OPTIONS:

1. Approve the application.
2. Modify the application with conditions.
3. Reject the application.



May 19, 2022

Rod McGillivray, Public Works Director
Town of Mesilla
P.O. Box 10
Mesilla, NM 88046

Re: 2022 - 2023 Local Government Road Fund Program

Dear Mr. McGillivray:

The State Transportation Commission approved the above program during their **May 19th meeting**.

	Entity Share	State Share	Project Total
Cooperative Agreement	\$28,706.00	\$86,118.00	\$114,824.00

A resolution passed by the governing body or agency head respectively adopting the project and verifying its priority standing with the Public Entity is the next item needed. The resolution should contain the scope of work as submitted to the Transportation Commission and shown on the preliminary offer letter forwarded to your office in **April 2022**. **The monetary amounts approved by the STC are listed above**. Additional information to be included in the resolution is the route & termini and control number **HW2 L100525**.

A sample resolution is included for your convenience.**

****There are two sample resolutions included with this notification.** If you are asking for match waiver this year, please submit the "match waiver sample resolution" along with the "letter of intent to apply for a hardship waiver" (samples attached). If you will not be asking for match waiver then submit the normal resolution included in your samples.

Please submit the resolution no later than June 30th. This will allow the time needed to have the agreement fully executed by the October 31st deadline. **Any agreement not fully executed by this deadline could result in the loss of your funding.**

Agreements will be forwarded for signature upon receipt of the resolution in our office. **Please remember that NO aspect of the project can begin prior to the execution of the agreement.**

We appreciate your assistance and please email debraA.hudson@state.nm.us, or call 575-640-2779 if you should have any questions or need further assistance.

Sincerely,

Debbie Hudson
State Funding Programs Supervisor
NMDOT District One

Enclosures

**Michelle Lujan
Grisham**
Governor

Justin Reese
Acting Cabinet Secretary

Commissioners

Jennifer Sandoval
Commissioner
District 1

Bruce Ellis
Commissioner
District 2

Hilma Chynoweth
Commissioner
District 3

Walter Adams
Commissioner
District 4

Thomas C. Taylor
Commissioner
District 5

Charles Lundstrom
Commissioner
District 6



TOWN OF MESILLA

Public Works Department
P.O. Box 10, Mesilla, New Mexico 88046
Office: (575) 524-3262
Fax: (575) 541-6327

June 7, 2022

NMDOT District 1
Trent Doolittle, P.E., District Engineer
Debbie Hudson, State Funding Programs Supervisor
2912 E. Pine St.
Deming, NM 88030

**Re: Request for LGRF Hardship Match Waiver
Control Number (HW2 L100525)**

Total Amount: \$114,824.00
Entity Share: \$ 28,706.00
State Share: \$ 86,118.00

Dear Mr. Doolittle:

The Town of Mesilla is interested in applying for the LGRF Hardship Match Waiver per the NM Administrative Code 18 NMAC 27.3.8 for our pending funding through the FY22-2023 LGRF Program.

NMAC 27.3.8 allows Public Entities who are experiencing financial hardship to apply for a Match Waiver of all or part of the Public Entity match normally required for participation in the Local Government Road Fund.

The Town of Mesilla qualifies for the Match Waiver in the amount of \$28,706.00 for the LGRF Project for year 2022-2023 to complete the following scope of work: Engineering, survey, and design to construct the roadways by removing and replacing the existing deteriorated base course and pavement, removing, and replacing failed concrete curbing as needed, adjustment of utilities, and drainage improvements, resurface with new asphalt pavement with the route and termini being Calle de Cura from Calle de Segunda to Calle de Quinta.

If you have any questions, please do not hesitate to contact me.

Sincerely,

Rod McGillivray, Public Works Director



Town of Mesilla, New Mexico

RESOLUTION NO. 2022-05

A RESOLUTION AUTHORIZING PARTICIPATION IN THE LOCAL GOVERNMENT ROAD FUND PROGRAM ADMINISTERED BY THE NEW MEXICO DEPARTMENT OF TRANSPORTATION

WHEREAS, the Town of Mesilla and the New Mexico Department of Transportation have entered into a grant agreement under the Local Government Transportation Fund Program for a local road project.

WHEREAS, the total cost of the project will be \$114,824.00 to be funded in proportional share by the parties hereto as follows:

- a. New Mexico Department of Transportation's share shall be 75% or \$86,118.00
and
- b. Town of Mesilla's proportional matching share shall be 25% or \$28,706.00

TOTAL PROJECT COST IS \$114,824.00

The Town of Mesilla shall pay all costs, which exceed the total amount of \$114,824.00

NOW THEREFORE, be it resolved in open session that **Town of Mesilla** determines, resolves, and orders as follows:

That the project for this Cooperative agreement is adopted and has a priority standing.

The agreement terminates on December 31, 2023 and the **Town of Mesilla** incorporates all the agreements, covenants, and understandings between the parties hereto concerning the subject matter hereof, and all such covenants, agreements and understandings have been merged into the written agreement.

NOW THEREFORE, be it resolved by the Town of Mesilla to enter into Cooperative Agreement for Project Control Number HW2 L100525 with the New Mexico Department of Transportation for LGRF Program for year 2022-2023 for: Engineering, survey, and design to construct the roadways by removing and replacing the existing deteriorated base course and pavement, removing, and replacing failed concrete curbing as needed, adjustment of utilities, and drainage improvements, resurface with new asphalt pavement with the route and termini being Calle de Cura from Calle de Segunda to Calle de Quinta.

PASSED AND APPROVED this 13th day of June 2022.

Nora Barraza, Mayor

ATTESTED:

Rani Bush
Town Clerk/Treasurer



RESOLUTION NO. 2022-06

**A RESOLUTION AUTHORIZING PARTICIPATION IN THE
LOCAL GOVERNMENT ROAD FUND PROGRAM AND REQUEST FOR MATCH WAIVER
ADMINISTERED BY NEW MEXICO DEPARTMENT OF TRANSPORTATION**

WHEREAS, the **Town of Mesilla** and the New Mexico Department of Transportation enter into a Cooperative Agreement.

WHEREAS, the total cost of the project will be **\$114,824.00** to be funded in proportional share by the parties hereto as follows:

- a. New Mexico Department of Transportation's share shall be 75% or **\$86,118.00**
and
- b. **Town of Mesilla's** proportional matching share shall be 25% or **\$28,706.00** if Hardship for Match Waiver is not deemed to be present by Department of Finance and Administration and the Department of Transportation

TOTAL PROJECT COST IS **\$114,824.00**

Town of Mesilla shall pay all costs, which exceed the total amount of **\$114,824.00**

WHEREAS, the **Town of Mesilla** has a limited tax base, which limits the funding for meeting the proportional matching share; and, a fund exists in the NMDOT appropriated by the New Mexico State Legislature for Public Entities in need of "hardship" match money and **Town of Mesilla** requests participation in this Match Waiver Program in the amount of **\$28,706.00**

Now therefore, be it resolved in official session that **Town of Mesilla** determines, resolves, and orders as follows:

That the project for this Cooperative Agreement is adopted and has a priority standing.

The agreement terminates on **December 31, 2023** and the **Town of Mesilla** incorporates all the agreements, covenants, and understandings between the parties hereto concerning the subject matter hereof, and all such covenants, agreements and understandings have been merged into the written agreement.

NOW therefore, be it resolved by the **Town of Mesilla** to enter into Cooperative Agreement Control Number **HW2 L100525** with the New Mexico Department of Transportation for LGRF Project for year 2022-2023 to **Engineering, survey, and design to construct the roadways by removing and replacing the existing deteriorated base course and pavement, removing, and replacing failed concrete curbing as needed, adjustment of utilities, and drainage improvements, resurface with new asphalt pavement with the route and termini being Calle de Cura from Calle de Segunda to Calle de Quinta.**

PASSED AND APPROVED this 13th day of June 2022.

Nora Barraza
Mayor

ATTESTED:

Rani Bush
Town Clerk/Treasurer

**STATE OF NEW MEXICO
TOURISM DEPARTMENT
Cooperative Agreement**

THIS AGREEMENT, numbered **23-418-1003001000-21**, is made and entered into by **State of New Mexico Tourism Department**, hereinafter referred to as the “NMTD,” and **Town of Mesilla**, hereinafter referred to as the “Partner” (collectively the “Parties”) and is effective as set forth below.

RECITALS

WHEREAS, the New Mexico Legislature appropriated funds to NMTD for the purpose of carrying out the duties of the NMTD, which include providing a coordinated statewide perspective with regard to tourism activities; and

WHEREAS, NMTD desires to coordinate this effort through cooperative programs with matching funds for certain tourism-related non-profit organizations, local and tribal governments; and

WHEREAS, Partner wishes to leverage the New Mexico True brand (Brand) with advertising and media-related services provided by NMTD to stimulate tourism activities and is willing to contribute funds to further the Parties’ efforts to that effect;

NOW, THEREFORE, IT IS AGREED BETWEEN THE PARTIES, for the express and sole purpose of stimulating tourism in New Mexico, in consideration of the mutual covenants and obligations contained herein, as follows:

I. Obligations of Partner.

- A. Meet or exceed the requirements of its FY23 Cooperative Marketing Application to promote travel within and/or to New Mexico through advertising and media efforts as defined in the FY23 Award Summary, as approved by NMTD and attached hereto as *Exhibit A*.
- B. Make all payments in accordance with the requirements listed in *Exhibit A*.
- C. Agree to follow the established New Mexico True Brand Style Guide available via link from [NMTrueCoOp.org](https://nmtruecoop.org).
- D. Obtain prior approval from NMTD for any and all use of the Brand. NMTD reserves the right to inspect any usage of the Brand to ensure proper quality and consistency.
- E. Collaborate with NMTD, providing timely inputs and responses to communications that ensure successful execution of all initiatives as outlined in *Exhibit A*.
- F. Acknowledge that any failure to adhere to the parameters set forth herein may affect Partner’s eligibility for future awards.
- G. In addition to the above obligations, for all Flex funds expended, Partner must also:
 1. Acknowledge that it has access to, and agrees to comply with, the FY23 Request for Reimbursement Form via the online grant platform and related cycle documents located at <https://nmtourism.smapply.io>. The online application form and Partner’s responses to that form are incorporated herein by reference.

2. Obtain prior approval from the Brand Resource Hub located at <https://nmtourism.pica9.com> and retain approval identification number for all cobranded creative materials, i.e. any printed or digital collateral, advertising, etc. that incorporate any part of the New Mexico True brand logo including the customized “logo lockup” provided by NMTD for Partner’s use in conjunction with cooperative marketing initiatives.
3. Fully and accurately complete and timely submit the Request for Reimbursement Form(s) and end-of-year Tracking and Impact Report.
 - i. Requests for payment of expenses incurred between July 1, 2022 and May 31, 2023 must be submitted within 30 days of placement in market.
 - ii. All requests for payment must be received by June 10, 2023. Incomplete or illegible requests will not be processed.
 - iii. The end-of-year Tracking and Impact Report must be submitted to NMTD no later than July 10, 2023. Failure to do so may result in forfeiture of reimbursement and/or affect Partner’s future opportunities.

II. Obligations of NMTD.

- A. Provide assets necessary to meet requirements for logo integration.
- B. For all Flex funds expended, NMTD will reimburse Partner for all eligible expenses, in accordance with the amounts listed in *Exhibit A*, upon receipt of a completed Request for Reimbursement Form along with all required supporting documentation.
- C. Upon receipt of MMP Partner funds, NMTD will:
 1. Communicate with media vendors and secure ad placement and/or services as agreed upon and set forth in *Exhibit A*.
 2. Provide documentation to Partner to verify agreed upon deliverables were made in accordance with *Exhibit A*.
 3. Pay media vendors for ad placement and/or services.
 4. Collect and share campaign performance measurement data with Partner.

III. Copyright and Quality Control.

- A. For the term of this Agreement, the NMTD grants to the Partner a nonexclusive, nontransferable, worldwide right and license to use the New Mexico True Brand in furtherance of the Partner’s promotion and advertising of and within New Mexico, as outlined in *Exhibit A*. This includes but is not limited to the creation and distribution of advertisements defined in the original application submitted and is subject to NMTD creative approval prior to placement.
- B. All Brand usage and creative must be submitted to and approved by NMTD prior to use and must adhere to Brand Style Guide available via link from NMTrueCoOp.org.
- C. NMTD will exercise its right to inspect Partner’s creative assets designed for and used in conjunction with marketing and promotional campaigns that employ Brand logos to ensure that such use is of proper quality and otherwise consistent with this Agreement and may terminate this Agreement should it determine that Partner did not obtain prior approval or that its Brand use is inconsistent.

- D. All materials developed or acquired by the Partner under this Agreement shall become the jointly owned property of the State of New Mexico. Nothing produced, in whole or in part, by the Partner under this Agreement shall be the subject of an application for copyright by or on behalf of Partner. Furthermore, NMTD may access and use Partner's advertising and other creative production assets at its sole discretion.

IV. Additional Terms & Conditions:

- A. The terms of this Agreement are contingent upon sufficient appropriations and authorization being made by the Legislature of New Mexico. If sufficient appropriations and authorization are not made, this Agreement shall terminate upon written notice given by NMTD to the Partner. NMTD's decision as to whether sufficient appropriations are available shall be accepted by the Partner and shall be final.
- B. This Agreement shall become effective upon its execution by both Parties and shall terminate on June 30, 2023. Either party may terminate or seek to further negotiate this Agreement upon ninety (90) days written notice to the other. In the event of termination, neither party may nullify obligations already incurred for performance or failure to perform, prior to the date of termination and any outstanding reimbursements shall be made pro rata.
- C. A "Force Majeure Event" is defined as an event or effect that can be neither anticipated nor controlled which renders performance of the terms of this Agreement impossible, impracticable, or unsafe, including public health emergencies such as COVID-19. If a Force Majeure Event occurs, the parties' respective obligations hereunder will be excused fully, without any additional obligation, and each of the parties shall bear its own costs incurred in connection with this Agreement.
- D. This Agreement shall not be altered, changed, or amended except by instrument of writing executed by the Parties hereto.
- E. Neither party shall be responsible for liability incurred as a result of the other party's acts or omissions in connection with this Agreement. Any liability incurred by either party in connection with this Agreement is subject to the immunities and limitations of the New Mexico Tort Claims Act, §41-4-1, et seq., NMSA 1978, as amended
- F. This Agreement is governed by the laws of the State of New Mexico.
- G. This Agreement is not intended to and does not create any rights in any persons or entity not a party hereto.
- H. Any notice required to be given to either Party by this Agreement shall be in writing and shall be delivered in person, by courier service or by electronic mail, facsimile, U.S. mail, either first class or certified, return receipt requested, postage prepaid, as follows:

To NMTD: New Mexico Tourism Department
 Brandy Velarde
 491 Old Santa Fe Trail | Santa Fe, NM 87501
 505-500-7890 | brandy.velarde@state.nm.us

To Partner: Nora Barraza
Town of Mesilla
2231 Avenida de Mesilla,
Mesilla, NM, 88046
mayor@mesillanm.gov

- I. The individual signing below on behalf of the Partner represents and warrants that he or she has the authority to bind the Partner, and that no further action, resolution or approval from the Partner is necessary to enter into a binding agreement.

IN WITNESS WHEREOF, the Parties have executed this Agreement as of the date of signature by the NMTD Deputy Cabinet Secretary listed below.

By: _____ Date: _____
Nora Barraza, Town of Mesilla PARTNER

Approved for legal sufficiency:

By: _____ Date: _____
Jennifer Saavedra, General Counsel NMTD

By: _____ Date: _____
Isabel B. Lopez, Chief Financial Officer NMTD

By: _____ Date: _____
Allison P. Martinez, Deputy Cabinet Secretary NMTD

**NEW MEXICO TOURISM DEPARTMENT
FY23 COOPERATIVE MARKETING PROGRAM**

**EXHIBIT A
AWARD SUMMARY**



Organization Name: Mesilla, Town of
 Primary Contact: Dorothy Sellers
 Email: dorothys@mesillanm.gov
 Phone: 5755713890

#	TOTAL \$ VALUE	NMTD \$	PARTNER \$ COMMITMENT	PARTNER \$ DUE 7/8/22	PARTNER \$ DUE 12/1/22
3	\$17,127.00	\$11,418.00	\$5,709.00	\$2,854.50	\$2,854.50
MEDIA MENU PLAN (MMP): SMART SELECT OPTIONS					
3	\$17,127.00	\$11,418.00	\$5,709.00	\$2,854.50	\$2,854.50
FLEX: REQUEST SUMMARY					
0	\$0.00	\$0.00	\$0.00		

MEDIA MENU PLAN (MMP) AWARDS

TYPE	Details	#	TOTAL \$ VALUE	NMTD \$	PARTNER \$ COMMITMENT	PARTNER \$ DUE 7/8/22	PARTNER \$ DUE 12/1/22
CONTENT / ORGANIC SOCIAL	Social Content Package (12 mo)	1	\$10,800.00	\$7,200.00	\$3,600.00	\$1,800.00	\$1,800.00
	DETAILS						
CONTENT / ORGANIC SOCIAL	Crowdsourced Photo & Video Management	1	\$1,989.00	\$1,326.00	\$663.00	\$331.50	\$331.50
	DETAILS						
CONTENT / ORGANIC SOCIAL	Still Photo Shoot (1 Day, 30 Selects)	1	\$4,338.00	\$2,892.00	\$1,446.00	\$723.00	\$723.00
	DETAILS						

FLEX FUND AWARDS

TYPE	INITIATIVE	#	TOTAL \$ VALUE	NMTD \$	PARTNER \$ COMMITMENT

WORK PLAN

**Between the
Town of Mesilla
And**

**UNITED STATES DEPARTMENT OF AGRICULTURE
ANIMAL AND PLANT HEALTH INSPECTION SERVICE
WILDLIFE SERVICES**

July 1, 2022 through June 30, 2023

Pursuant to Cooperative Service Agreement between Town of Mesilla and the United States Department of Agriculture (USDA), Animal and Plant Health Inspection Service (APHIS), Wildlife Services (WS), this Work Plan defines the objectives, plan of action, resources and budget for an Integrated Wildlife Damage Management (IWDM) program to be conducted from July 1, 2022 through June 30, 2023.

I. OBJECTIVES/GOALS

The Town of Mesilla and WS have identified the following objectives to be accomplished in this program

A. To maintain a cooperative Wildlife Services program between USDA/APHIS/WS and the Town of Mesilla. This will enable the Town of Mesilla to receive the necessary technical assistance and operational support to efficiently and effectively reduce wildlife conflicts adversely impacting the Town of Mesilla. The program also provides for the protection of public health and safety and the protection of other resources.

B. The results or benefits to be expected from a cooperative WDM program include APHIS-WS expertise, APHIS-WS operational and technical assistance, the provision of necessary control equipment and the distribution of control materials such as restricted use pesticide, APHIS-WS coordination and planning support with federal and state wildlife agencies such as the U.S. Fish and Wildlife Service and the New Mexico Department of Game and Fish in order to properly conduct WDM activities.

C. To specifically apply direct control methods for predator damage control for Town of Mesilla.

II. PLAN OF ACTION

To accomplish this goal, the following general field services will be provided:

Technical Assistance - WS will provide technical support to the Town of Mesilla on other issues that may impact predatory and/or nuisance species control, including habitat modifications,

response design, and recommendations for the area of concern.

Predator Identification & Removal - when livestock, crop or natural resource damage is verified.

Nuisance Wildlife Removal - when property damage is identified.

Removal of Wildlife Displaying Aggressive Behavior - causing injury to county residents.

Outreach - Outreach activities include meeting with the constituents of the **county**, school group demonstrations and predator/damage awareness training.

APHIS-WS will assign one part-time (or the equivalent) Wildlife Specialist and will also provide a vehicle, field supplies and equipment. Work hours will be used to provide operational and technical assistance, travel and conduct administrative duties such as reports and training seminars.

To provide these basic services, APHIS-WS will:

1. Assign one part-time (or the equivalent) Wildlife Specialist and will also provide a vehicle, field supplies and equipment. Work hours will be used to provide operational and technical assistance, travel and conduct administrative duties.

Conflict resolutions may be sought using two basic approaches; direct control operations and technical assistance.

A. Damage Control Strategies:

1. Operational control work. If the desired approach requires skilled technicians, actual work will be performed by qualified Wildlife Specialists. Operational management methods will be directed toward specific individuals or local populations by selecting the time, locations, technique, and specific applications of the control tool. Determinations of method will depend on considerations of efficacy, selectivity, human safety, effectiveness, practicability, and cost.

- a) Corrective control on local depredating target populations or individual animals.
- b) Preventive control or the general suppression of a local population of target species.
- c) Non-lethal control strategies will be recommended whenever appropriate to reduce or prevent conflicts.

2) Technical Assistance. When feasible, problems will be resolved by technical assistance.

B. Control Methods and Techniques:

Basic operational damage control methods to address various wildlife/human conflicts include: (1) catch pole (2) foot hold traps (3) live cage traps. Also, combinations of different methodologies and degrees of intensity, depending on local conditions and history of specific damage situations may be utilized. Each control method has advantages and disadvantages; each is effective in some situations but not in others. These methods will be used singly or in combinations, depending on the circumstances involved.

III. PROCUREMENT

Purchases of supplies, equipment and services will be made by APHIS-WS through its administrative system. Any equipment and supplies purchased under the terms of this agreement will remain the property of APHIS-WS.

IV. STIPULATIONS AND RESTRICTIONS

APHIS-WS activities under this cooperative effort will be limited to the State of New Mexico, Town of Mesilla. Techniques will be environmentally sound, safe, and selective. If applicable, both Federal and State permits will be secured to perform wildlife damage management activities, and those activities will be conducted within the policy guidelines of APHIS-WS. All program activities will be conducted in compliance with Local, State, and Federal regulations.

a. All operations shall have the joint concurrence of USDA-WS and Town of Mesilla and shall be under the direct supervision of USDA-WS. All operations will adhere to the specific work financial plan requirements required by both USDA-WS and Mesilla. USDA-WS will conduct the program in accordance with its established operating policies and all applicable state and federal laws and county regulations and requirements.

b. Control on Public Lands: An Agreement for Control of Animal Damage on Non-private Property (WS Form 12 A) or an appropriate NEPA document will be executed between USDA-WS and the public land administrator(s)/manager(s) before any USDA-WS work is conducted.

c. USDA-WS will use only USDA-WS employees and volunteers. All USDA-WS personnel will follow WS Directive 2.510, which prohibits benefiting personally from any animals(s) whole or in part, taken while conducting official duties.

d. The program will be supervised by District Supervisor Rudy Fajardo (575) 494-5305, monitoring and authoritative oversight will be by the New Mexico, State Director, Jon Grant (505) 208-3003.

e. In the absence of a finalized county budget, a letter of intent must be provided pending final budget approval. The cooperative Wildlife Services Program, due to Congressional Federal appropriations, law cannot continue unless a mutual agreement is negotiated by June 30, 2022.

V. COST ESTIMATE FOR SERVICES

Under this agreement the Town of Mesilla will provide **\$3,500.00**, funding up to 100 hours per year to the project.

In accordance with the Debt Collection Improvement Act (DCIA) of 1996, bills issued by WS are due and payable within 30 days of receipt. The DCIA requires that all debts older than 120 days be forwarded to debt collection centers or commercial collection agencies for more aggressive action. Debtors have the option to verify, challenge and compromise claims, and have access to administrative appeals procedures which are both reasonable and protect the interests of the United States.

VI. FINANCIAL PLAN

Cost Element		Full Cost
Personnel Compensation	\$	2,723.87
Travel	\$	-
Vehicles	\$	-
Other Services	\$	-
Supplies and Materials	\$	28.79
Equipment	\$	-
Subtotal (Direct Charges)		\$ 2,752.66
Pooled Job Costs	11.00%	\$ 302.79
Indirect Costs	16.15%	\$ 444.55
Aviation Flat Rate Collection		\$ -
Agreement Total		\$ 3,500.00

The distribution of the budget from this Financial Plan may vary as necessary to accomplish the purpose of this agreement, but may not exceed: \$3,500.00

The financial point of contact for this Work Plan is Patsy Baca, Budget Analyst (505) 346-2640. This plan has been approved by the USDA APHIS WS Western Regional Office for use in the State of New Mexico for cost-share agreements. Copies of this approval and the APHIS Overhead waiver are available upon request.

Town of Mesilla Point of Contact:

Nara I. Baug
(575) 524-3262

VI. AUTHORIZATION

Approved by:

District Supervisor

Date

Approved by:

Authorized Representative
Town of Mesilla

Date

TOWN OF MESILLA

BOARD ACTION FORM

ITEM:

Approval of recommendation to hire Melissa Padilla as part-time temporary Recreation Supervisor (Lead), and Dylan Nosbisch and Kathryn Newberry as part-time temporary Recreation Supervisors for Mesilla Summer Recreation Program made possible by a donation from El Paso Electric.

BACKGROUND:

The Recreation Supervisors will oversee over 30 children ages 5-to-12 as part of the Town of Mesilla 4-week Summer Recreation Program June 20-July 15, 2021 at Mesilla Community Center. All three Recreation Supervisors will be responsible for planning and implementing various activities for the participants. The Recreation Supervisor (Lead) will also serve as the on-site supervisor and decision-maker.

SUPPORT INFORMATION:

None

BOARD OPTIONS:

1. Approve
2. Modify
3. Reject

SUBMITTED BY: Dorothy Sellers
BOT MEETING DATE: 06/13/2022

DEPARTMENT: Community Events

Community Development Monthly Report for May 2022

- Training in Las Cruces for League of Zoning officials.
- Completed PZHAC packets for agendas.
- Worked with ASC putting together application packets for them to review.
- Worked on assessor's monthly report for previous months from September 2021 to March 2022 to submit to Dona Ana County.
- Working with fire Marshal's office and other agencies to correct addresses in the Town of Mesilla as well as business addresses.
- Attending to customers with building and permit questions. Answering phone calls and emails.

Joe Padilla

6/8/2022

Community Projects Report

Project	Description
Current Contact information	Dorothy Sellers Email: DorothyS@mesillanm.gov Work: 575-524-3262 Cell:575-571-3890
Promote Mesilla and area businesses	Working with Experience Mesilla members in an attempt to bridge the gap. A liaison has not been appointed yet but look forward to working to build a better Mesilla
Visitors Guide	New Visitors guides have been printed and distribution has begun. I have extra copies at the Visitors center if anyone is interested
Social Media and website	Keep social media up to date with things happening in Mesilla. Will continue to push visitors to the website. Mesilla website is now visible on Google search.
Mercado	Working with Mercado vendors to keep moving forward. New openings have been filled and look forward to a successful year. Background checks will be done on all existing and incoming vendors.
Clean & Beautiful Grant	Application for FY23 has been submitted. Am awaiting award announcements. FY22 closes on June 15th
NM Tourism Grant	Mesilla was granted a 2:1 match offer. FY23 will focus on building the asset library currently in Mesilla's possession and promotion through Social media and printed ads.
Summer Music Series	This years lineup has been announced. Additional posters are available at town hall if interested

Summer Recreation	Summer Rec applications to open the Week of May 9. Program will be shortened this year due to public schools returning early.
Fourth of July	Neal McCowan to provide music. Planet Fireworks has graciously agreed to host a fireworks display once more.
Fourth of July	Neal McCowan to provide music. Planet Fireworks has graciously agreed to host a fireworks display once more. I would like to look into a town cook off event for next year.
Summer Interns	Overseeing a group of 6 interns. The interns will be assisting with Public Works, Summer Rec and general office tasks.
Lodgers Tax Committee	Seeing volunteers to sit on the Lodgers tax advisory committee. If you know anyone interested, please send them my way
Diez y Seis de Septiembre	Preparations for 2022 Diez Y Seis has begun. Applications will go live the 1 st week in July.

**TOWN OF MESILLA FIRE DEPARTMENT
MONTHLY BOT REPORT**



DATE: May, 2022

MAJOR ADDITIONS TO INVENTORY

NONE

MAINTENANCE OF EQUIPMENT

Brush 31 - replaced bad pump seal, repair foam system leak, replaced batteries. Battalion 32 - replaced battery, repaired emergency lights front and rear. Brush 33 - replaced defective foam level indicator.

COMMENTS

We have seen an 11% increase in fires over the last two months mostly due to brush fires with some increase in building fires. We continue to monitor conditions around the Town related to the continued hot and dry conditions. The drought line is moving south in Dona Ana county and will reach our area soon unless much needed precipitation is received. We had three personnel complete EMS classes at DACC this semester. Well done! The Cinco de Mayo Fiesta went well with 3 individuals needing medical attention however none required transport. Fire and safety inspections went well and a total of 83 persons participated in the Home Fire Sprinkler presentations. Burn Tower training took place this month with sixteen personnel participating. Thank you DAC Fire and Emergency Services for the use of your training facilities and support.

SUBMITTED BY

Fire Chief Kevin Hoban _____

Mesilla Fire Department

Mesilla, NM

This report was generated on 6/7/2022 11:42:24 PM



Incident Statistics

Zone(s): All Zones | Start Date: 05/01/2022 | End Date: 05/31/2022

INCIDENT COUNT			
INCIDENT TYPE		# INCIDENTS	
EMS		24	
FIRE		20	
TOTAL		44	
TOTAL TRANSPORTS (N2 and N3)			
APPARATUS	# of APPARATUS TRANSPORTS	# of PATIENT TRANSPORTS	TOTAL # of PATIENT CONTACTS
Bat31	0	0	6
Bat32	0	0	3
BR31	0	0	1
E31	0	0	1
SQ32	0	0	8
TOTAL	0	0	19
PRE-INCIDENT VALUE		LOSSES	
\$0.00		\$0.00	
CO CHECKS			
TOTAL			
MUTUAL AID			
Aid Type		Total	
Aid Given		9	
Aid Received		1	
OVERLAPPING CALLS			
# OVERLAPPING		% OVERLAPPING	
4		9.09	
LIGHTS AND SIREN - AVERAGE RESPONSE TIME (Dispatch to Arrival)			
Station	EMS	FIRE	
Mesilla Fire Main Station 31	0:12:41	0:05:59	
AVERAGE FOR ALL CALLS		0:09:20	
LIGHTS AND SIREN - AVERAGE TURNOUT TIME (Dispatch to Enroute)			
Station	EMS	FIRE	
Mesilla Fire Main Station 31	0:00:54	0:01:40	
AVERAGE FOR ALL CALLS		0:01:19	
AGENCY	AVERAGE TIME ON SCENE (MM:SS)		
Mesilla Fire Department	71:24		

Only Reviewed Incidents included. EMS for Incident counts includes only 300 to 399 Incident Types. All other incident types are counted as FIRE. CO Checks only includes Incident Types: 424, 736 and 734. # Apparatus Transports = # of incidents where apparatus transported. # Patient Transports = All patients transported by EMS. # Patient Contacts = # of PCR contacted by apparatus. This report now returns both NEMSIS 2 & 3 data as appropriate. For overlapping calls that span over multiple days, total per month will not equal Total count for year.

Mesilla Fire Department

Mesilla, NM

This report was generated on 6/8/2022 12:05:36 AM



Breakdown by Major Incident Types for Date Range

Zone(s): All Zones | Start Date: 05/01/2022 | End Date: 05/31/2022

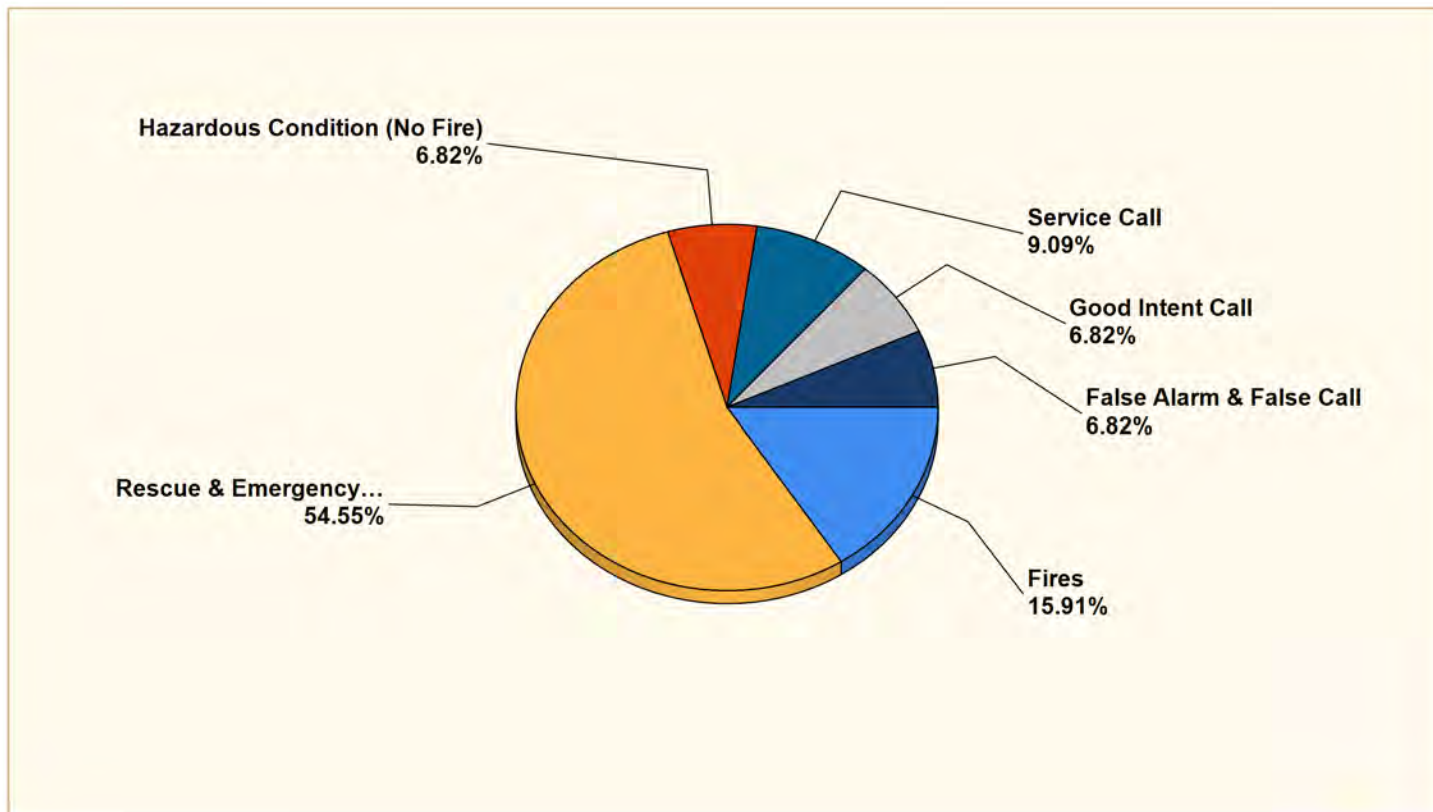

MAJOR INCIDENT TYPE	# INCIDENTS	% of TOTAL
Fires	7	15.91%
Rescue & Emergency Medical Service	24	54.55%
Hazardous Condition (No Fire)	3	6.82%
Service Call	4	9.09%
Good Intent Call	3	6.82%
False Alarm & False Call	3	6.82%
TOTAL	44	100%

Only REVIEWED and/or LOCKED IMPORTED incidents are included. Summary results for a major incident type are not displayed if the count is zero.



Detailed Breakdown by Incident Type

INCIDENT TYPE	# INCIDENTS	% of TOTAL
111 - Building fire	1	2.27%
113 - Cooking fire, confined to container	1	2.27%
141 - Forest, woods or wildland fire	1	2.27%
142 - Brush or brush-and-grass mixture fire	4	9.09%
311 - Medical assist, assist EMS crew	5	11.36%
320 - Emergency medical service, other	1	2.27%
321 - EMS call, excluding vehicle accident with injury	12	27.27%
322 - Motor vehicle accident with injuries	3	6.82%
381 - Rescue or EMS standby	3	6.82%
412 - Gas leak (natural gas or LPG)	1	2.27%
421 - Chemical hazard (no spill or leak)	1	2.27%
440 - Electrical wiring/equipment problem, other	1	2.27%
520 - Water problem, other	1	2.27%
551 - Assist police or other governmental agency	1	2.27%
554 - Assist invalid	1	2.27%
561 - Unauthorized burning	1	2.27%
611 - Dispatched & cancelled en route	2	4.55%
631 - Authorized controlled burning	1	2.27%
733 - Smoke detector activation due to malfunction	1	2.27%
743 - Smoke detector activation, no fire - unintentional	1	2.27%
745 - Alarm system activation, no fire - unintentional	1	2.27%
TOTAL INCIDENTS:	44	100%

Only REVIEWED and/or LOCKED IMPORTED incidents are included. Summary results for a major incident type are not displayed if the count is zero.



Mesilla Fire Department

Mesilla, NM

This report was generated on 6/8/2022 12:07:25 AM



Breakdown by Major Incident Types for Date Range

Zone(s): All Zones | Start Date: 01/01/2022 | End Date: 05/31/2022

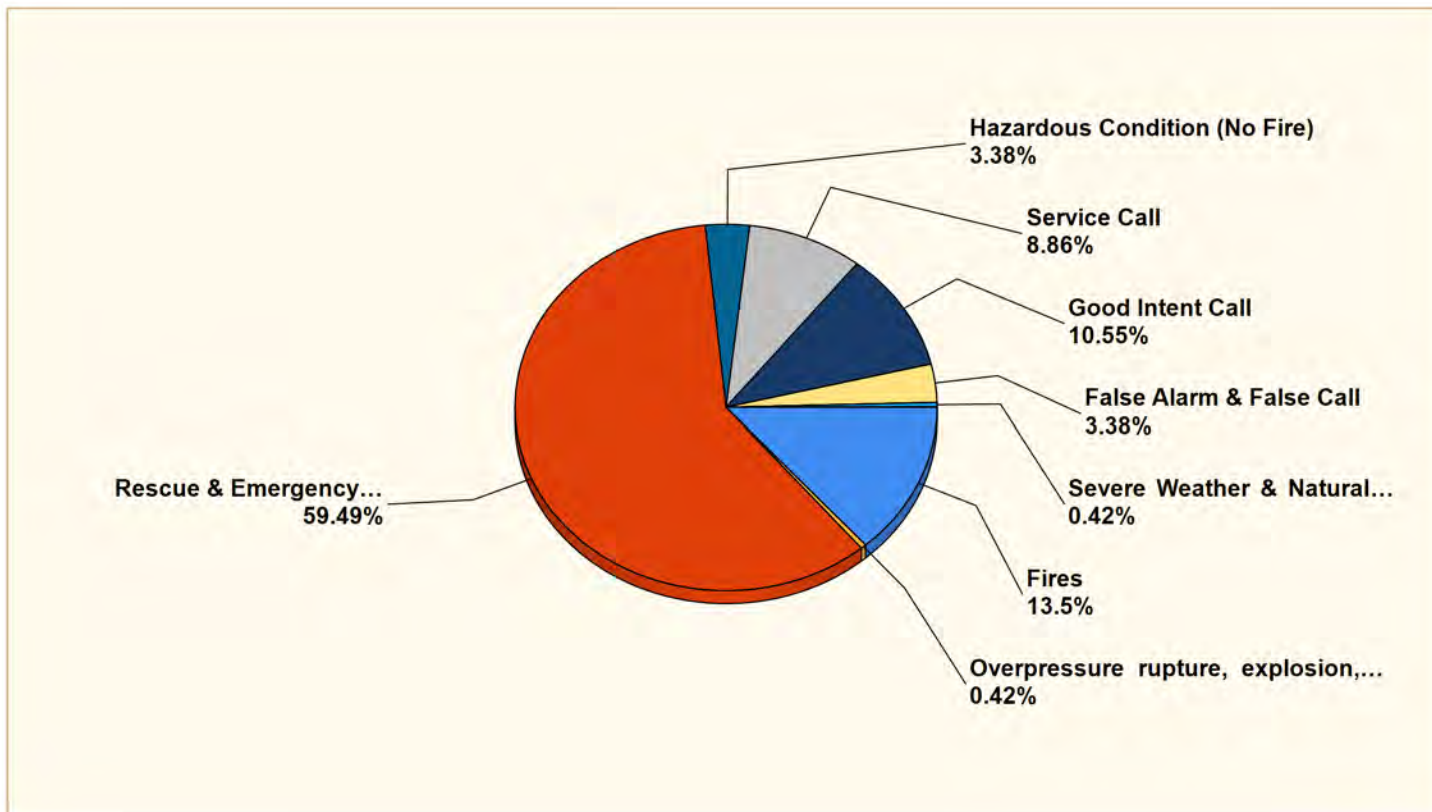

MAJOR INCIDENT TYPE	# INCIDENTS	% of TOTAL
Fires	32	13.5%
Overpressure rupture, explosion, overheating - no fire	1	0.42%
Rescue & Emergency Medical Service	141	59.49%
Hazardous Condition (No Fire)	8	3.38%
Service Call	21	8.86%
Good Intent Call	25	10.55%
False Alarm & False Call	8	3.38%
Severe Weather & Natural Disaster	1	0.42%
TOTAL	237	100%

Only REVIEWED and/or LOCKED IMPORTED incidents are included. Summary results for a major incident type are not displayed if the count is zero.



Detailed Breakdown by Incident Type

INCIDENT TYPE	# INCIDENTS	% of TOTAL
111 - Building fire	6	2.53%
113 - Cooking fire, confined to container	1	0.42%
132 - Road freight or transport vehicle fire	1	0.42%
136 - Self-propelled motor home or recreational vehicle	1	0.42%
141 - Forest, woods or wildland fire	1	0.42%
142 - Brush or brush-and-grass mixture fire	19	8.02%
143 - Grass fire	2	0.84%
170 - Cultivated vegetation, crop fire, other	1	0.42%
251 - Excessive heat, scorch burns with no ignition	1	0.42%
300 - Rescue, EMS incident, other	2	0.84%
311 - Medical assist, assist EMS crew	16	6.75%
320 - Emergency medical service, other	2	0.84%
321 - EMS call, excluding vehicle accident with injury	82	34.6%
322 - Motor vehicle accident with injuries	17	7.17%
324 - Motor vehicle accident with no injuries.	6	2.53%
350 - Extrication, rescue, other	1	0.42%
381 - Rescue or EMS standby	15	6.33%
400 - Hazardous condition, other	1	0.42%
412 - Gas leak (natural gas or LPG)	4	1.69%
421 - Chemical hazard (no spill or leak)	1	0.42%
440 - Electrical wiring/equipment problem, other	1	0.42%
444 - Power line down	1	0.42%
511 - Lock-out	1	0.42%
520 - Water problem, other	1	0.42%
522 - Water or steam leak	3	1.27%
551 - Assist police or other governmental agency	3	1.27%
553 - Public service	1	0.42%
554 - Assist invalid	8	3.38%
561 - Unauthorized burning	4	1.69%
611 - Dispatched & cancelled en route	17	7.17%
622 - No incident found on arrival at dispatch address	4	1.69%
631 - Authorized controlled burning	2	0.84%
650 - Steam, other gas mistaken for smoke, other	1	0.42%
651 - Smoke scare, odor of smoke	1	0.42%
733 - Smoke detector activation due to malfunction	1	0.42%
735 - Alarm system sounded due to malfunction	2	0.84%
743 - Smoke detector activation, no fire - unintentional	4	1.69%
745 - Alarm system activation, no fire - unintentional	1	0.42%
813 - Wind storm, tornado/hurricane assessment	1	0.42%
TOTAL INCIDENTS:	237	100%

Only REVIEWED and/or LOCKED IMPORTED incidents are included. Summary results for a major incident type are not displayed if the count is zero.



Mesilla Fire Department

Mesilla, NM

This report was generated on 6/8/2022 12:02:09 AM



Response Activity Report

Start Date: 05/01/2022 | End Date: 05/31/2022

INCIDENT #	DATE	APPARATUS ID	ALARM TIME	ARRIVE TIME	RESPONSE TIME	ADDRESS
111 - Building fire						
2022-00222	05/17/2022	Bat31	09:44:57	09:53:55	00:08:58	2689 CALLE CUARTA
2022-00222	05/17/2022	Bat32	09:44:57	09:52:13	00:07:16	2689 CALLE CUARTA
2022-00222	05/17/2022	E32	09:44:57	09:56:52	00:11:55	2689 CALLE CUARTA
Subtotal Count: 3		111 - Building fire Average Response Time: 00:09:23				
113 - Cooking fire, confined to container						
2022-00227	05/18/2022	Bat31	17:27:57	18:00:00	00:32:03	1983 CALLE DEL NORTE
2022-00227	05/18/2022	Bat32	17:27:57	17:34:34	00:06:37	1983 CALLE DEL NORTE
2022-00227	05/18/2022	E32	17:27:57	17:58:55	00:30:58	1983 CALLE DEL NORTE
2022-00227	05/18/2022	PPE	17:27:57	17:58:55	00:30:58	1983 CALLE DEL NORTE
Subtotal Count: 4		113 - Cooking fire, confined to container Average Response Time: 00:25:09				
141 - Forest, woods or wildland fire						
2022-00207	05/09/2022	Bat31	06:04:10	06:22:33	00:18:23	300 S MOTEL BLVD
2022-00207	05/09/2022	Bat32	06:04:10	06:19:33	00:15:23	300 S MOTEL BLVD
2022-00207	05/09/2022	BR31	06:04:10	06:32:03	00:27:53	300 S MOTEL BLVD
Subtotal Count: 3		141 - Forest, woods or wildland fire Average Response Time: 00:20:33				
142 - Brush or brush-and-grass mixture fire						
2022-00213	05/12/2022	Bat31	10:33:53	10:43:11	00:09:18	1523 PAISANO RD
2022-00213	05/12/2022	Bat32	10:33:53	10:34:20	00:00:27	1523 PAISANO RD
2022-00213	05/12/2022	BR31	10:33:53	10:48:08	00:14:15	1523 PAISANO RD
2022-00216	05/13/2022	Bat31	08:57:13	08:57:13	00:00:00	1710 PAISANO RD
2022-00216	05/13/2022	BR31	08:57:13	09:18:37	00:21:24	1710 PAISANO RD
2022-00219	05/14/2022	Bat32	13:01:24	13:17:57	00:16:33	MESILLA DAM RD
2022-00219	05/14/2022	BR31	13:01:24	13:18:52	00:17:28	MESILLA DAM RD
2022-00226	05/18/2022	BR31	13:45:46	16:14:41	02:28:55	HIGHWAY 185
Subtotal Count: 8		142 - Brush or brush-and-grass mixture fire Average Response Time: 00:28:32				
311 - Medical assist, assist EMS crew						
2022-00196	05/02/2022	Bat31	15:29:36	15:41:08	00:11:32	402 BASON DR
2022-00196	05/02/2022	Bat32	15:29:36	15:41:01	00:11:25	402 BASON DR
2022-00197	05/02/2022	Bat31	16:16:00	16:36:22	00:20:22	6120 ASWAN CT
2022-00197	05/02/2022	SQ32	16:16:00	17:13:00	00:57:00	6120 ASWAN CT
2022-00211	05/12/2022	Bat31	00:40:19	00:53:10	00:12:51	2320 CALLE DE SANTA ANA
2022-00211	05/12/2022	Bat32	00:40:19	00:51:23	00:11:04	2320 CALLE DE SANTA ANA
2022-00211	05/12/2022	BR31	00:40:19	00:53:39	00:13:20	2320 CALLE DE SANTA ANA
2022-00220	05/14/2022	Bat32	14:59:40	15:17:25	00:17:45	2977 MESILLA HILLS DR
2022-00220	05/14/2022	BR31	14:59:40	15:17:27	00:17:47	2977 MESILLA HILLS DR
2022-00228	05/19/2022	Bat31	03:24:33	04:11:23	00:46:50	3440 W PICACHO AVE

Calls by Incident Type. Does not include calls where there was no response.



2022-00228	05/19/2022	BR31	03:24:33	04:09:28	00:44:55	3440 W PICACHO AVE
Subtotal Count: 11		311 - Medical assist, assist EMS crew Average Response Time: 00:24:04				
320 - Emergency medical service, other						
2022-00203	05/06/2022	Bat32	20:52:56	22:36:20	01:43:24	2236 W UNION AVE
2022-00203	05/06/2022	SQ32	20:52:56	22:31:35	01:38:39	2236 W UNION AVE
Subtotal Count: 2		320 - Emergency medical service, other Average Response Time: 01:41:01				
321 - EMS call, excluding vehicle accident with injury						
2022-00195	05/01/2022	E31	17:35:48	17:42:15	00:06:27	2720 CALLE TERCERA
2022-00200	05/03/2022	Bat31	16:48:58	16:52:46	00:03:48	2915 GLASS RD
2022-00201	05/06/2022	Bat31	13:29:39	13:41:49	00:12:10	1420 W UNION AVE
2022-00202	05/06/2022	SQ32	19:36:31	19:37:26	00:00:55	2251 CALLE DE SANTIAGO
2022-00204	05/07/2022	Bat31	00:13:47	00:28:34	00:14:47	2122 CALLE DE ARROYO
2022-00204	05/07/2022	Bat32	00:13:47	00:24:09	00:10:22	2122 CALLE DE ARROYO
2022-00204	05/07/2022	SQ32	00:13:47	00:21:01	00:07:14	2122 CALLE DE ARROYO
2022-00208	05/09/2022	Bat31	13:20:49	13:38:07	00:17:18	1300 W UNIVERSITY AVE
2022-00208	05/09/2022	Bat32	13:20:49	13:32:00	00:11:11	1300 W UNIVERSITY AVE
2022-00214	05/12/2022	Bat31	12:03:40	12:33:00	00:29:20	1300 W UNIVERSITY AVE
2022-00214	05/12/2022	SQ32	12:03:40	12:31:01	00:27:21	1300 W UNIVERSITY AVE
2022-00215	05/12/2022	Bat31	13:46:15	14:12:45	00:26:30	3863 WILLOW GLEN DR
2022-00215	05/12/2022	SQ32	13:46:15	14:13:48	00:27:33	3863 WILLOW GLEN DR
2022-00221	05/17/2022	Bat31	07:32:02	08:13:22	00:41:20	3440 W PICACHO AVE
2022-00234	05/27/2022	Bat31	12:40:07	12:48:19	00:08:12	2526 SNOW RD
2022-00234	05/27/2022	SQ32	12:40:07	12:48:02	00:07:55	2526 SNOW RD
2022-00235	05/28/2022	Bat31	10:40:00	10:40:00	00:00:00	1430 PORTLAND DR
2022-00235	05/28/2022	SQ32	10:40:00	10:40:00	00:00:00	1430 PORTLAND DR
2022-00237	05/29/2022	Bat31	23:26:37	23:46:58	00:20:21	2171 CALLE DE PARIAN
Subtotal Count: 19		321 - EMS call, excluding vehicle accident with injury Average Response Time: 00:14:21				
322 - Motor vehicle accident with injuries						
2022-00199	05/03/2022	Bat31	13:09:53	13:13:48	00:03:55	AVENIDA DE MESILLA
2022-00199	05/03/2022	Bat32	13:09:53	13:16:07	00:06:14	AVENIDA DE MESILLA
2022-00199	05/03/2022	BR31	13:09:53	13:23:47	00:13:54	AVENIDA DE MESILLA
2022-00210	05/11/2022	Bat31	17:02:20	17:23:39	00:21:19	120 INTERSTATE 10
2022-00238	05/31/2022	Bat31	09:04:30	09:20:08	00:15:38	129 INTERSTATE 10
Subtotal Count: 5		322 - Motor vehicle accident with injuries Average Response Time: 00:12:12				
381 - Rescue or EMS standby						
2022-00205	05/07/2022	Bat31	10:51:23	10:51:44	00:00:21	2170 CALLE DE PARIAN
2022-00205	05/07/2022	BR31	10:51:23	10:51:44	00:00:21	2170 CALLE DE PARIAN
2022-00205	05/07/2022	BR33	10:51:23	10:51:44	00:00:21	2170 CALLE DE PARIAN
2022-00205	05/07/2022	SQ32	10:51:23	10:51:44	00:00:21	2170 CALLE DE PARIAN
2022-00206	05/08/2022	Bat31	11:00:00	11:38:35	00:38:35	2170 CALLE DE PARIAN
2022-00206	05/08/2022	Bat32	11:28:35	11:28:35	00:00:00	2170 CALLE DE PARIAN
2022-00236	05/28/2022	Bat31	12:06:14	12:19:56	00:13:42	310 CAPRI RD
2022-00236	05/28/2022	SQ32	12:06:14	12:19:52	00:13:38	310 CAPRI RD
Subtotal Count: 8		381 - Rescue or EMS standby Average Response Time: 00:08:24				

Calls by Incident Type. Does not include calls where there was no response.



412 - Gas leak (natural gas or LPG)						
2022-00225	05/18/2022	Bat32	08:36:18	08:44:22	00:08:04	AVENIDA DE MESILLA
Subtotal Count: 1		412 - Gas leak (natural gas or LPG) Average Response Time: 00:08:04				
421 - Chemical hazard (no spill or leak)						
2022-00231	05/23/2022	Bat31	22:19:25	22:34:24	00:14:59	3026 LOS ARENALES ST
2022-00231	05/23/2022	Bat32	22:19:25	22:31:11	00:11:46	3026 LOS ARENALES ST
2022-00231	05/23/2022	BR31	22:19:25	22:30:00	00:10:35	3026 LOS ARENALES ST
Subtotal Count: 3		421 - Chemical hazard (no spill or leak) Average Response Time: 00:12:26				
440 - Electrical wiring/equipment problem, other						
2022-00229	05/21/2022	Bat31	15:36:02	16:28:02	00:52:00	2385 CALLE DE GUADALUPE
2022-00229	05/21/2022	Bat32	15:36:02	16:22:28	00:46:26	2385 CALLE DE GUADALUPE
2022-00229	05/21/2022	E32	15:36:02	16:27:11	00:51:09	2385 CALLE DE GUADALUPE
Subtotal Count: 3		440 - Electrical wiring/equipment problem, other Average Response Time: 00:49:51				
520 - Water problem, other						
2022-00212	05/12/2022	Bat31	10:17:16	10:28:38	00:11:22	CALLE DE ALVAREZ
Subtotal Count: 1		520 - Water problem, other Average Response Time: 00:11:22				
551 - Assist police or other governmental agency						
2022-00223	05/17/2022	Bat31	22:17:22	23:05:05	00:47:43	S FAIRACRES RD
Subtotal Count: 1		551 - Assist police or other governmental agency Average Response Time: 00:47:43				
554 - Assist invalid						
2022-00198	05/03/2022	Bat31	05:29:37	05:42:19	00:12:42	402 BASON DR
2022-00198	05/03/2022	Bat32	05:29:37	05:38:45	00:09:08	402 BASON DR
Subtotal Count: 2		554 - Assist invalid Average Response Time: 00:10:55				
561 - Unauthorized burning						
2022-00209	05/09/2022	Bat31	22:47:21	23:01:18	00:13:57	2915 GLASS RD
Subtotal Count: 1		561 - Unauthorized burning Average Response Time: 00:13:57				
631 - Authorized controlled burning						
2022-00232	05/25/2022	Bat31	13:20:09	13:35:21	00:15:12	CALLE DE EL PASO
Subtotal Count: 1		631 - Authorized controlled burning Average Response Time: 00:15:12				
733 - Smoke detector activation due to malfunction						
2022-00217	05/13/2022	Bat31	09:18:13	09:31:46	00:13:33	2808 SNOW RD
2022-00217	05/13/2022	BR31	09:18:13	09:35:00	00:16:47	2808 SNOW RD
Subtotal Count: 2		733 - Smoke detector activation due to malfunction Average Response Time: 00:15:10				
743 - Smoke detector activation, no fire - unintentional						
2022-00224	05/18/2022	Bat31	05:52:23	06:03:23	00:11:00	2355 AVENIDA DE MESILLA
2022-00224	05/18/2022	Bat32	05:52:23	06:03:23	00:11:00	2355 AVENIDA DE MESILLA
2022-00224	05/18/2022	E32	05:52:23	06:03:23	00:11:00	2355 AVENIDA DE MESILLA
Subtotal Count: 3		743 - Smoke detector activation, no fire - unintentional Average Response Time: 00:11:00				
745 - Alarm system activation, no fire - unintentional						
2022-00230	05/23/2022	Bat31	13:13:25	13:21:42	00:08:17	1553 AVENIDA DE MESILLA
Subtotal Count: 1		745 - Alarm system activation, no fire - unintentional Average Response Time: 00:08:17				
Grand Total: 82		Average Response Time for All Incident Types: 00:20:17				

Calls by Incident Type. Does not include calls where there was no response.

Mesilla Fire Department

Mesilla, NM

This report was generated on 6/8/2022 12:04:36 AM



Occupancies Inspected for Date Range

Start Date: 05/01/2022 | End Date: 05/31/2022

OCCUPANCY	ID	ADDRESS	ZONE	LAST INSPECTION
Dona Maria		90144 Matterhorn		05/07/2022
Gorditas zacatexas		5849 sturgeon		05/07/2022
kashos tacos		7520 Franklin loop		05/07/2022
Kona Ice		1920 Martha		05/07/2022
los leones		Calle de Parian		05/07/2022
Nuts-R-Us		27 gardner		05/07/2022
ositos biscochitos		580 s. valley		05/07/2022
T-Bird Tacos		1827 la puente		05/07/2022
Up in Smoke		2309 bassett		05/07/2022

of Occupancies Inspected: 9

% Occupancies Inspected: 5.20

Included occupancies are those that have a LOCKED inspection on record for the date range provided.



Mesilla Fire Department

Mesilla, NM

This report was generated on 6/7/2022 11:46:27 PM



Total Hours by Volunteers for May, 2022

Pay Grades: All Pay Grades | Start Date: 05/01/2022 | End Date: 05/31/2022

PERSONNEL	INCIDENT TIME	TRAINING TIME	EVENT TIME	TOTAL TIME
Aguilar, Alexander J	4:00	0:00	17:00	21:00
Brown, Tyler S	32:39	27:00	82:00	141:39
Calderazzo, Vincent S	0:00	4:00	0:00	4:00
Davis-Whited, Crystal L	19:12	14:00	9:00	42:12
Dorr, Patrick E	2:00	38:00	28:00	68:00
Dove, Michael S	0:00	0:00	4:00	4:00
Embury, Andy G	10:45	0:00	7:00	17:45
Evans, Harry A	5:15	39:00	18:00	62:15
Fernandez III, Humberto	11:09	16:00	66:30	93:39
Fernandez, Sergio A	1:45	16:00	0:00	17:45
Franco, Gabriel Z	2:00	0:00	42:00	44:00
Frietze, Trevor R	6:15	12:00	0:00	18:15
Gaytan, Melina A	0:00	14:00	9:00	23:00
Klebansky, George A	28:04	15:00	8:30	51:34
Linares-Chacon, Sebastian	0:00	3:00	15:30	18:30
Lucero, Sergio B	3:45	20:00	15:00	38:45
Manriquez, Humberto	0:45	0:00	20:30	21:15
Martinez, Mateo L	0:00	0:00	14:00	14:00
Martinez, William A	0:00	16:00	0:00	16:00
Mendez, Sergio M	2:30	6:30	18:00	27:00
Ortiz, Yvonne	1:45	11:00	16:30	29:15
Rogers, Travis A	2:00	12:00	39:30	53:30
Rossman, Tabitha A	3:00	3:00	1:00	7:00
Sanchez, Xavier	25:45	19:00	64:00	108:45
Thunhorst, Ines C	5:00	2:00	21:00	28:00
Whited, Gregory E	32:42	21:00	26:45	80:27
Zapfen, Jasha C	31:09	27:00	66:00	124:09
			TOTAL	1175:40;00

Mesilla Fire Department

Mesilla, NM

This report was generated on 6/8/2022 12:03:08 AM



Events per Event Type for Date Range (Landscape)

Start Date: 05/01/2022 | End Date: 05/31/2022

EVENT TYPE	DATE	EVENT NAME	CATEGORY	LOCATION	HOURS	PARTICIPANTS
Daily Operations Shift						
	05/01/2022	A Shift	Shifts	Fire House 31	9	Tyler Brown, Humberto Fernandez III, Jasha Zapien
	05/03/2022	C shift	Shifts	Fire station 31	25	Humberto Fernandez III, Gabriel Franco
	05/05/2022	B Shift	Shifts	Firehouse 31	8.5	Yvonne Ortiz, Travis Rogers
	05/06/2022	C Shift	Shifts	Fire House 31	11	Tyler Brown, Humberto Fernandez III, Sergio Lucero, Sergio Mendez, Xavier Sanchez, Jasha Zapien
	05/09/2022	C Shift	Shifts	Fire House 31	15	Tyler Brown, Patrick Dorr, Humberto Fernandez III, Gabriel Franco
	05/10/2022	A-Shift	Shifts	Firehouse 31	9	Sebastian Linares-Chacon, Humberto Manriquez
	05/11/2022	B-Shift	Shifts	Firehouse 31	6.5	Sebastian Linares-Chacon, Humberto Manriquez
	05/11/2022	B Shift	Shifts	Firehouse 31	13	Yvonne Ortiz, Travis Rogers
	05/12/2022	C Shift	Shifts	Fire House 31	15	Tyler Brown, Humberto Fernandez III, Mateo Martinez, Sergio Mendez, Xavier Sanchez, Jasha Zapien
	05/14/2022	B Shift	Shifts	Fire House 31	5	Tyler Brown, Sergio Lucero, Xavier Sanchez, Jasha Zapien
	05/15/2022	C Shift	Shifts	Fire House 31	4	Tyler Brown, Jasha Zapien
	05/17/2022	B Shift	Shifts	Firehouse 31	26	Humberto Fernandez III, Gabriel Franco, Humberto Manriquez, Travis Rogers
	05/23/2022	B Shift	Shifts	Firehouse 31	21.5	Travis Rogers
	05/24/2022	C Shift	Shifts	Fire House 31	13	Tyler Brown, Patrick Dorr, Michael Dove, Humberto Fernandez III, Melina Gaytan, Xavier Sanchez, Jasha Zapien

Only LOCKED events included.



emergencyreporting.com

Doc Id: 753

Page # 1 of 3

EVENT TYPE	DATE	EVENT NAME	CATEGORY	LOCATION	HOURS	PARTICIPANTS
	05/28/2022	C Shift	Shifts	Fire House 31	16.5	Xavier Sanchez
	05/30/2022	C Shift	Shifts	Fire House 31	6	Tyler Brown, Patrick Dorr, Sergio Lucero, Yvonne Ortiz, Jasha Zapien

Total Hours for Daily Operations Shift: 204

Administration Shift						
	05/03/2022	A shift	Administrative	Home	4	Ines Thunhorst
	05/04/2022	Officers Meeting	Officer Meeting	FMO	2.5	Crystal Davis-Whited, Andy Embury, Harry Evans, George Klebansky, Gregory Whited
	05/07/2022	Administrative Shift Tele-work	Administrative	Tele-work home	2.5	Harry Evans
	05/07/2022	Administrative Shift	Administrative	Telework	3	Crystal Davis-Whited, Gregory Whited
	05/13/2022	Administrative Shift	Administrative	fire House 31	3.5	Harry Evans
	05/23/2022	Administrative Shift Tele-work	Administrative	Tele-work home	2	Harry Evans
	05/24/2022	Town of Mesilla BoT meeting	Administrative	Town Hall	1	Crystal Davis-Whited, Kevin Hoban, George Klebansky, Gregory Whited
	05/27/2022	Administrative Shift	Administrative	Telework	2.5	Crystal Davis-Whited
	05/27/2022	Administrative Shift	Administrative	fire House 31	7.5	Harry Evans

Total Hours for Administration Shift: 28.5

EMS Division Shift						
	05/12/2022	B shift	Shifts	Fire Station 31	8.75	Alexander Aguilar, Ines Thunhorst
	05/27/2022	C Shift	Shifts	Fire station 31	8.25	Alexander Aguilar, Ines Thunhorst

Total Hours for EMS Division Shift: 17

Prevention Division Shift						
	05/19/2022	Fire follow up and inspection	Prevention Event	Andeles Doghouse	4.5	Andy Embury, Gregory Whited
	05/24/2022	Double Eagle expansion	Prevention Event	Double Eagle Restaurant	3	Gregory Whited
	05/25/2022	2001 Ave de Mesilla construction	Prevention Event	2001 Ave de Mesilla	2	Gregory Whited

Total Hours for Prevention Division Shift: 9.5

Only LOCKED events included.



EVENT TYPE	DATE	EVENT NAME	CATEGORY	LOCATION	HOURS	PARTICIPANTS
Special Assignment						
	05/23/2022	Mesilla Elementary Water Day	Water Day	Mesilla Elementary School	6	Tyler Brown, Melina Gaytan, George Klebansky, Tabitha Rossman, Xavier Sanchez, Gregory Whited, Jasha Zapien

Total Hours for Special Assignment: 6

Prevention Event						
	05/27/2022	DACES interview board	Prevention Event	Dona Ana training facility	4.25	Gregory Whited
	05/27/2022	2001 Avenida de Mesilla Sprinkler issues	Prevention Event	telework	1.5	Gregory Whited
	05/31/2022	PZHAC meeting and meeting with Mayor	Prevention Event	Town of Mesilla Town Hall	2	Gregory Whited

Total Hours for Prevention Event: 7.75

Only LOCKED events included.



Mesilla Fire Department

Mesilla, NM

This report was generated on 6/7/2022 11:44:55 PM



Count of Classes by Personnel by Class Category

Passed/Failed: Both Passed and Failed | Personnel: All Personnel | Start Date: 05/01/2022 | End Date: 05/31/2022

Brown, Tyler S

Class Category	Class Count	Total Class Hours
EMS Training	1	2:00
I.S.O. Company Training	5	9:00
I.S.O. Drill Tower	1	8:00
I.S.O. Driver and Operator Training	2	8:00
Total for Brown, Tyler S	9	27:00

Calderazzo, Vincent S

Class Category	Class Count	Total Class Hours
I.S.O. Driver and Operator Training	1	4:00
Total for Calderazzo, Vincent S	1	4:00

Davis-Whited, Crystal L

Class Category	Class Count	Total Class Hours
EMS Training	1	2:00
I.S.O. Drill Tower	1	8:00
I.S.O. Driver and Operator Training	1	4:00
Total for Davis-Whited, Crystal L	3	14:00

Dorr, Patrick E

Class Category	Class Count	Total Class Hours
I.S.O. Company Training	4	7:00
I.S.O. Drill Tower	1	8:00
I.S.O. Driver and Operator Training	1	4:00
Total for Dorr, Patrick E	6	19:00

Evans, Harry A

Class Category	Class Count	Total Class Hours
EMS Training	2	2:00
I.S.O. Company Training	3	29:00
I.S.O. Drill Tower	1	8:00
Total for Evans, Harry A	6	39:00

Fernandez III, Humberto

Class Category	Class Count	Total Class Hours
EMS Training	1	2:00
I.S.O. Company Training	2	2:00
I.S.O. Drill Tower	1	8:00
I.S.O. Driver and Operator Training	1	4:00
Total for Fernandez III, Humberto	5	16:00

This report lists a count of Classes completed by each Person, for each Class Category. Optionally filtered by Personnel and Passage or Failure. Time shown in Hours and Minutes. If "All Personnel" is selected, this report also includes non-agency Personnel. Only non-Archived Classes that have been Reviewed are included. This report pulls training hours from the Training Code Hours field on the Info Page.

Fernandez, Sergio A

Class Category	Class Count	Total Class Hours
EMS Training	1	2:00
I.S.O. Company Training	1	2:00
I.S.O. Drill Tower	1	8:00
I.S.O. Driver and Operator Training	1	4:00
Total for Fernandez, Sergio A	4	16:00

Frietze, Trevor R

Class Category	Class Count	Total Class Hours
I.S.O. Drill Tower	1	8:00
I.S.O. Driver and Operator Training	1	4:00
Total for Frietze, Trevor R	2	12:00

Gaytan, Melina A

Class Category	Class Count	Total Class Hours
I.S.O. Company Training	2	2:00
I.S.O. Drill Tower	1	8:00
I.S.O. Driver and Operator Training	1	4:00
Total for Gaytan, Melina A	4	14:00

Hoban, Kevin M

Class Category	Class Count	Total Class Hours
I.S.O. Drill Tower	1	8:00
Total for Hoban, Kevin M	1	8:00

Klebansky, George A

Class Category	Class Count	Total Class Hours
EMS Training	1	2:00
I.S.O. Company Training	1	2:00
I.S.O. Drill Tower	1	8:00
I.S.O. Driver and Operator Training	1	4:00
Total for Klebansky, George A	4	16:00

Linares-Chacon, Sebastian

Class Category	Class Count	Total Class Hours
I.S.O. Company Training	1	3:00
Total for Linares-Chacon, Sebastian	1	3:00

Lucero, Sergio B

Class Category	Class Count	Total Class Hours
EMS Training	1	2:00
I.S.O. Company Training	2	5:00
I.S.O. Drill Tower	1	8:00
I.S.O. Driver and Operator Training	1	4:00
Total for Lucero, Sergio B	5	19:00

Martinez, William A

This report lists a count of Classes completed by each Person, for each Class Category. Optionally filtered by Personnel and Passage or Failure. Time shown in Hours and Minutes. If "All Personnel" is selected, this report also includes non-agency Personnel. Only non-Archived Classes that have been Reviewed are included. This report pulls training hours from the Training Code Hours field on the Info Page.



Class Category	Class Count	Total Class Hours
I.S.O. Company Training	1	2:00
I.S.O. Drill Tower	1	8:00
I.S.O. Driver and Operator Training	1	4:00
Total for Martinez, William A	3	14:00

Mendez, Sergio M

Class Category	Class Count	Total Class Hours
EMS Training	1	2:00
I.S.O. Company Training	1	2:00
Total for Mendez, Sergio M	2	4:00

Ortiz, Yvonne

Class Category	Class Count	Total Class Hours
I.S.O. Company Training	1	3:00
I.S.O. Drill Tower	1	8:00
Total for Ortiz, Yvonne	2	11:00

Rogers, Travis A

Class Category	Class Count	Total Class Hours
I.S.O. Drill Tower	1	8:00
I.S.O. Driver and Operator Training	1	4:00
Total for Rogers, Travis A	2	12:00

Rossman, Tabitha A

Class Category	Class Count	Total Class Hours
I.S.O. Drill Tower	1	8:00
I.S.O. Driver and Operator Training	1	4:00
Total for Rossman, Tabitha A	2	12:00

Sanchez, Xavier

Class Category	Class Count	Total Class Hours
EMS Training	1	2:00
I.S.O. Company Training	1	1:00
I.S.O. Drill Tower	1	8:00
I.S.O. Driver and Operator Training	2	8:00
Total for Sanchez, Xavier	5	19:00

Thunhorst, Ines C

Class Category	Class Count	Total Class Hours
EMS Training	1	2:00
Total for Thunhorst, Ines C	1	2:00

Whited, Gregory E

Class Category	Class Count	Total Class Hours
EMS Training	1	2:00
I.S.O. Company Training	1	3:00
I.S.O. Drill Tower	1	8:00
I.S.O. Driver and Operator Training	2	8:00

This report lists a count of Classes completed by each Person, for each Class Category. Optionally filtered by Personnel and Passage or Failure. Time shown in Hours and Minutes. If "All Personnel" is selected, this report also includes non-agency Personnel. Only non-Archived Classes that have been Reviewed are included. This report pulls training hours from the Training Code Hours field on the Info Page.



Total for Whited, Gregory E		5	21:00
Zapien, Jasha C			
Class Category	Class Count	Total Class Hours	
EMS Training	1	2:00	
I.S.O. Company Training	5	9:00	
I.S.O. Drill Tower	1	8:00	
I.S.O. Driver and Operator Training	2	8:00	
Total for Zapien, Jasha C	9	27:00	

This report lists a count of Classes completed by each Person, for each Class Category. Optionally filtered by Personnel and Passage or Failure. Time shown in Hours and Minutes. If "All Personnel" is selected, this report also includes non-agency Personnel. Only non-Archived Classes that have been Reviewed are included. This report pulls training hours from the Training Code Hours field on the Info Page.

Mesilla Fire Department

Mesilla, NM

This report was generated on 06/08/2022



Response Mode: Lights and Sirens | Start Date: 05/01/2022 | End Date:05/31/2022

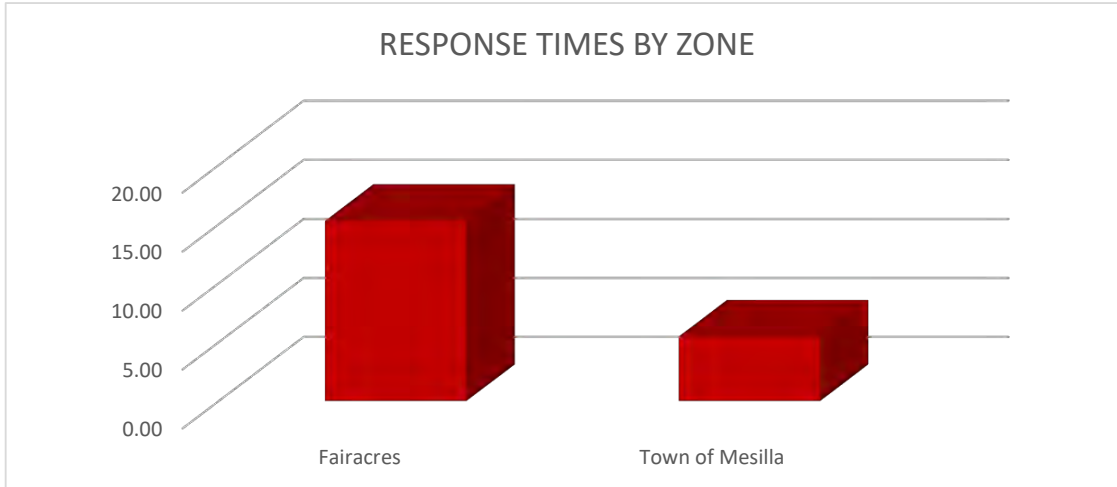

Zone	AVERAGE RESPONSE TIME (in minutes)
Fairacres	15.27
Town of Mesilla	5.47
Town of Mesilla No Crew on Duty	12.52
Town of Mesilla Crew on Duty	4.19

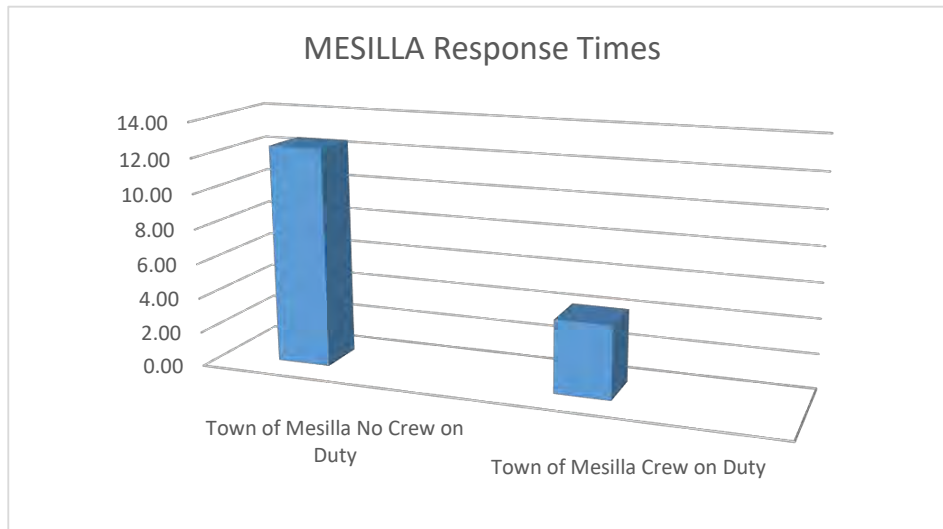

Only REVIEWED incidents included. Response Time is Dispatched to Arrived.

Mesilla Fire Department

Mesilla, NM

This report was generated on 6/8/2022 12:00:42 AM



Incident Type Count per Zone for Date Range

Start Date: 05/01/2022 | End Date: 05/31/2022

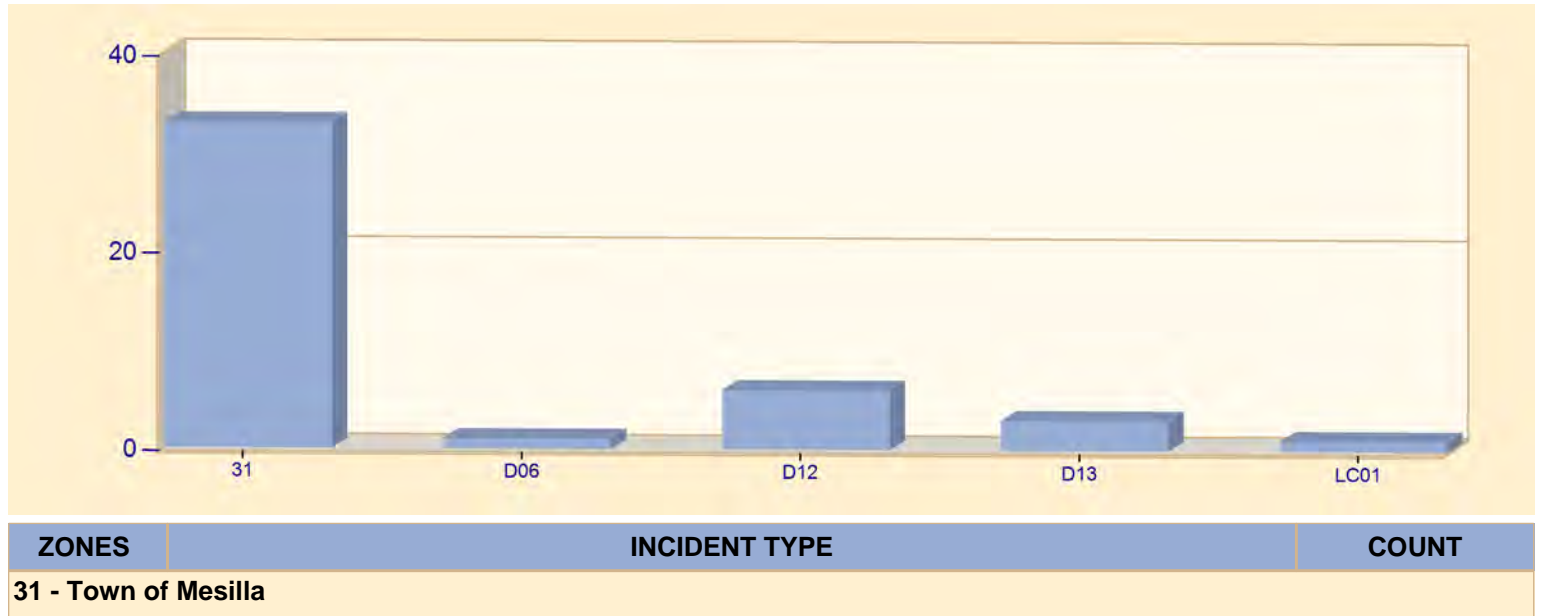

Zone information is defined on the Basic Info 3 screen of an incident.
Only REVIEWED incidents included.



ZONES	INCIDENT TYPE	COUNT
	111 - Building fire	1
	113 - Cooking fire, confined to container	1
	142 - Brush or brush-and-grass mixture fire	2
	311 - Medical assist, assist EMS crew	2
	320 - Emergency medical service, other	1
	321 - EMS call, excluding vehicle accident with injury	9
	322 - Motor vehicle accident with injuries	1
	381 - Rescue or EMS standby	3
	412 - Gas leak (natural gas or LPG)	1
	421 - Chemical hazard (no spill or leak)	1
	440 - Electrical wiring/equipment problem, other	1
	520 - Water problem, other	1
	551 - Assist police or other governmental agency	1
	554 - Assist invalid	1
	561 - Unauthorized burning	1
	611 - Dispatched & cancelled en route	2
	631 - Authorized controlled burning	1
	733 - Smoke detector activation due to malfunction	1
	743 - Smoke detector activation, no fire - unintentional	1
	745 - Alarm system activation, no fire - unintentional	1
	<i>Total Incidents for 31 - Town of Mesilla</i>	33
D06 - Rincon		
	142 - Brush or brush-and-grass mixture fire	1
	<i>Total Incidents for D06 - Rincon:</i>	1
D12 - Fairacres		
	141 - Forest, woods or wildland fire	1
	311 - Medical assist, assist EMS crew	2
	321 - EMS call, excluding vehicle accident with injury	1
	322 - Motor vehicle accident with injuries	2
	<i>Total Incidents for D12 - Fairacres:</i>	6
D13 - South Valley		
	142 - Brush or brush-and-grass mixture fire	1
	311 - Medical assist, assist EMS crew	1
	321 - EMS call, excluding vehicle accident with injury	1
	<i>Total Incidents for D13 - South Valley:</i>	3
LC01 - City of Las Cruces		

Zone information is defined on the Basic Info 3 screen of an incident.
Only REVIEWED incidents included.



ZONES	INCIDENT TYPE	COUNT
	321 - EMS call, excluding vehicle accident with injury	1
	<i>Total Incidents for LC01 - City of Las Cruces:</i>	1
Total Count for all Zone:		44

Zone information is defined on the Basic Info 3 screen of an incident.
Only REVIEWED incidents included.





MESILLA MARSHAL DEPARTMENT

P.O. BOX 10 MESILLA, NM 88046 PHONE 575-526-4138 FAX 575-652-3776

To: Honorable Mayor and Mesilla Board of Trustees

This is the Monthly Report for May 2022, for the Mesilla Marshal's Department:

911 hang ups	6	Information report	8
Agency assist	15	Motor Vehicle Crashes	14
ACO calls	20	Obstruction	1
Assaults	2	Overdose	1
ATV complaints	3	Panic alarm	1
Auto burglary	3	Phone call	9
Auto theft	2	Prisoner Transport	5
Behavioral	2	Prowler	2
Burglary alarm	5	Public assist	5
Civil	2	Pursuit/foot	1
Codes	3	Reckless driver	3
CPR	1	Restraining order violation	1
Disturbances	26	Shots fired	1
DWI	2	Suicidal subject	6
Foot patrol	2	Supplement	17
Found property	3	Suspicious activity	13
Frequent patrol	10	Theft	5
Illegally parked vehicle	2	Traffic stops	98

Trespassing 6

Vagrancy 1

Vandalism/graffiti 1

Vehicle fire 1

Thank you,

Enrique Salas,
Marshal

Warrant service 3

Welfare check 6

Total # of calls for service 316



TOWN OF MESILLA

Public Works Department

P.O. Box 10, Mesilla, New Mexico 88046

Office: (575) 524-3262

Fax: (575) 541-6327

MEMORANDUM

Date: June 1, 2022

TO: Mayor Barraza and Board of Trustees

FROM: Rodney J. McGillivray, Public Works Director

RE: **Public Works Division Activity Report – May 2022**

On-going maintenance, custodial and operations:

On-call/standby for emergency repairs or assistance

Meter reading continues

Monthly water sampling and reporting is up-to-date

Monitoring of lift stations and review of reporting

Monitoring of water tank, wells, and pumps

Grounds maintenance on-going

Custodial responsibilities on-going

Utility location services

Valve exercise program continues

Trail Maintenance on-going

Vehicle maintenance on-going

New water services and water shut-offs (ownership change/nonpayment)

Miscellaneous items/work orders/accomplishments:

Set up and tear down for Fiesta

Completed Plaza drinking fountain repairs

Replaced evaporative coolers Public Safety Building

Electrical repairs at Community Center

Plaza sign repair and replacement

Painting/refreshing Plaza Fire Lane

Pressure washing Plaza weekly

Flood irrigation of parks continues

Continued hydrant inspection

Brick repair and replacement
Replaced dead tree(s) at Town Hall and Mesilla Elementary
Weed eradication continues
New service and water tap Avenida de Fuente
New sewer connection 2001 Avenida de Mesilla
Pothole repairs on Snow Road and Calle del Sur

Project update:

LGTPF Calle del Norte Trail Phase II – Project awarded to A-Mountain Construction. NTP set for June 12, 2022

SCADA – Received 60% design. Review underway. Meeting with BHI for design review pending.

LGRF (Calle de Cura) – Processing resolutions for both the LGRF funding program and the program match waiver.

Mesilla Water System Booster Replacement – Waiting for BLM permit finalization. Once BLM is complete, plans and specifications will be sent to NMED for review. Cost escalation is a concern. Project scope minimization is underway to stay within budget.

Mesilla Streetlight Improvements – Engineering near completion. Lighting mock-up and selection underway.

Calle de Picacho Drainage: Project design waiting on survey. Environmental study and certification is underway. Received project budget and schedule from Molzen Corbin.

TPF Calle de Picacho Roadway Improvements: Project design waiting on survey. Environmental study and certification is underway. Received project budget and schedule from Molzen Corbin.

Plaza Sidewalk Refurbishment – Project design waiting on survey. Environmental study and certification is underway. Received project budget. Project schedule needed.

Colonias - University Waterline Improvements – Colonias Award tentatively approved. Awaiting offer letter. BHI released to continued design which is currently still at 60% complete.