



# Town of Mesilla, New Mexico

THE BOARD OF TRUSTEES (BOT) OF THE TOWN OF MESILLA WILL HOLD A REGULAR MEETING AT THE MESILLA TOWN HALL, 2231 AVENIDA DE MESILLA.

MONDAY, April 11, 2022, AT 6:00 P.M.

## AGENDA

1. PLEDGE OF ALLEGIANCE
2. ROLL CALL & DETERMINATION OF A QUORUM
3. CHANGES TO THE AGENDA & APPROVAL
4. PUBLIC INPUT – The public is invited to address the Board for up to 3 minutes.
5. PRESENTATION
  - a) Tuba Day – April 30, 2022
6. APPROVAL OF CONSENT AGENDA: (The Board will be asked to approve by one motion the following items of recurring or routine business. The Consent Agenda is marked with an asterisk \*)
  - a) \*BOT MINUTES – Revised Minutes of Regular Meeting, March 14, 2022.
  - b) \*BOT MINUTES – Minutes of Regular Meeting, March 28, 2022.
  - c) \*PZHAC Case #061364 – 2043 Calle de Correo, submitted by Alison Tinsley to install a residential rooftop solar system, **Zoned: Historic Residential (HR)**.
  - d) \*PZHAC Case #061368 - 2305 Calle de Colon, submitted by Gerard Nevarez to coat exterior of house with elastomeric and clear coat wood on gate, no changes in colors. **Zoned Historic Residential (HR)**
  - e) \*PZHAC Case #061371 – 331 Capri Arc submitted by Francis Williams to install a ground mounted solar system. **Zoned: Historic Residential (HR)**
7. NEW BUSINESS
  - a) **For Approval:** Resolution 2022-03: Acceptance and Approval of the FY 2021 Audit – Presentation by Carmen Jimenez, Beasley, Mitchell & Co.
  - b) **For Approval:** Resolution 2022-04 Calle de Norte Phase II, Second Amendment to the Local Government Transportation Project Fund #LP10004 for extension of time.
  - c) **Discussion:** Film Production Process – Senator Jeff Steinborn and Jon Sepp
8. BOARD OF TRUSTEE COMMITTEE REPORTS
9. STAFF REPORTS
  - a) \*Community Development
  - b) \*Community Programs
  - c) \*Finance Department
  - d) \*Fire Department
  - e) \*Marshal Department
  - f) \*Public Works Department
10. BOARD OF TRUSTEE/STAFF COMMENTS
11. ADJOURNMENT

## NOTICE

If you need an accommodation for a disability to enable you to fully participate in the hearing or meeting, please contact us at 524-3262 at least one week prior to the meeting. The Mayor and Trustees request that all cell phones be turned off or set to vibrate. Members of the audience are requested to step outside the Board Room to respond to or to conduct a phone conversation. A copy of the agenda packet can be found online at [www.mesillanm.gov](http://www.mesillanm.gov).

Posted 04.6.2022 online and at the following locations: Town Clerk's Office 2231 Avenida de Mesilla, Public Safety Building 2670 Calle de Parian, Mesilla Community Center 2251 Calle de Santiago, Shorty's Food Mart 2290 Avenida de Mesilla, Ristramn Chile Co., 2531 Avenida de Mesilla and the U.S. Post Office 2253 Calle de Parian.

# Town of Mesilla



## - Proclamation -

### DECLARING APRIL 30, 2022 TUBA DAY IN MESILLA, NEW MEXICO

**WHEREAS**, the Town of Mesilla, New Mexico, is committed to promoting the arts and arts education through various civic activities in the community; and

**WHEREAS**, music is an vital part of a comprehensive arts education for students of all ages; and

**WHEREAS**, the tuba is an essential brass wind instrument and can be played as part of an orchestra, a brass ensemble or a solo performance; and

**WHEREAS**, Tuba Day is commemorated internationally and in more than 35 states to celebrate the depth and diversity of sound a tuba is capable of producing; and

**WHEREAS**, tubists are appreciated for their talent, perseverance and discipline in perfecting their craft.

**NOW THEREFORE**, Be It Resolved that I, Nora L. Barraza, proclaim the 30<sup>th</sup> of April as "Tuba Day" in Mesilla, New Mexico, to recognize the tubist as being a talented master of musical performance, and to learn more about the significance of the tuba in our musical society.

**SIGNED, SEALED AND PROCLAIMED** this April 11, 2022.

---

Nora L. Barraza  
Mayor



# Town of Mesilla, New Mexico

**BOARD OF TRUSTEES (BOT)  
TOWN OF MESILLA REGULAR MEETING  
MONDAY, MARCH 14, 2022, 6:00 P.M.**

**REVISED MINUTES**

**TRUSTEES:** Nora Barraza, Mayor  
Stephanie Johnson-Burick, Mayor Pro Tem  
Bivian Cadena, Trustee (Absent)  
Veronica Garcia, Trustee  
Adrianna Merrick, Trustee

**STAFF:** Rani Bush, Town Clerk/Treasurer  
Kevin Hoban, Fire Chief  
Rod McGillivray, Public Works Director  
Enrique Salas, Marshal  
Gloria Maya, Recorder

**PUBLIC:** Susan Krueger                      Veronica Alvarez  
Crystal Davis-Whited              Greg Whited  
Anthony Lucero                      George Klebansky  
Andy Embury

**1. PLEDGE OF ALLEGIANCE**

Mayor Barraza led the Pledge of Allegiance.

**2. ROLL CALL & DETERMINATION OF A QUORUM**

**Roll Call.**

**Present:** Mayor Barraza, Mayor Pro Tem Johnson-Burick, Trustee Garcia, Trustee Merrick

**3. CHANGES TO THE AGENDA & APPROVAL**

**Motion: To approve agenda, Moved by Mayor Pro Tem Johnson-Burick, Seconded by Trustee Garcia.**

**Roll Call Vote:** Motion passed (**summary:** Yes =3).

Mayor Pro Tem Johnson-Burick    Yes

Trustee Garcia    Yes

Trustee Merrick    Yes

**4. PUBLIC INPUT – The public is invited to address the Board for up to 3 minutes.**

Ms. Krueger stated the property, Case #061336-2001 Avenida de Mesilla, which abuts her property is zoned RF not C. She believes she would have been notified had zoning been changed.

**5. PRESENTATION**

**a) Athletic Training Month Proclamation**

Ms. Bush read the Athletic Training Month Proclamation.

54 **6. APPROVAL OF CONSENT AGENDA:** (The Board will be asked to approve by one motion the  
55 following items of recurring or routine business. The Consent Agenda is marked with an asterisk \*)

56 Mayor Pro Tem Johnson-Burick requested removing Case #061336 from the consent agenda.

57  
58 **Motion: To approve consent agenda as amended, Moved by Mayor Pro Tem Johnson-Burick, Seconded**  
59 **by Trustee Garcia.**

60  
61 **Roll Call Vote:** Motion passed (summary: Yes =3).

62 Mayor Pro Tem Johnson-Burick Yes

63 Trustee Garcia Yes

64 Trustee Merrick Yes

65  
66 a) **\*BOT MINUTES** – Minutes of regular meeting, February 28, 2022. *Approved by consent*  
67 *agenda*

68 b) **\*PZHAC Case #061336 – 2001 Avenida de Mesilla**, submitted by Charlie Rogers to build a  
69 commercial building. Construction of the building will be a metal building, with exterior walls  
70 completed in stucco and wood framing interior walls. **Zoned: General Commercial (C).**

71 Mayor Pro Tem Johnson-Burick asked for clarification regarding the zoning.

72  
73 Mayor Barraza stated this property is zoned C on the official map.

74  
75 Trustee Garcia asked if all requirements were met, i.e., sprinklers. He was asked to bring forward a map.

76  
77 Mayor Barraza stated that can be made a condition of approval. Mr. Padilla will inform Mr. Nevarez and the  
78 contractor that no permit will be issued until all is submitted.

79  
80 Trustee Garcia asked about parking and wanted assurance that the building will not come down.

81  
82 Mayor Barraza stated there is parking and the building will not come down.

83  
84 Mr. Whited stated the conditions need to include the sprinkler system and fire alarm system prior to issuing  
85 permit.

86  
87 **Motion: To approve PZHAC Case #061336 – 2001 Avenida de Mesilla, submitted by Charlie Rogers to**  
88 **build a commercial building. Construction of the building will be a metal building, with exterior walls**  
89 **completed in stucco and wood framing interior walls. Zoned: General Commercial(C) – w/conditions,**  
90 **Moved by Mayor Pro Tem Johnson-Burick, Seconded by Trustee Garcia.**

91  
92 **Roll Call Vote:** Motion passed (summary: Yes =3).

93 Mayor Pro Tem Johnson-Burick Yes

94 Trustee Garcia Yes

95 Trustee Merrick Yes

96  
97 c) **\*PZHAC Case #060959 - 1900 Calle de Pecana**, submitted by Ray Carlson for Lago  
98 Development Inc. a request to renew a building permit to finish construction of house,  
99 **Zoned: Historic Residential (HR). Approved by consent agenda**

100  
101 **7. NEW BUSINESS:**

102 a) **For Approval: Appeal on PZHAC Case #061333 - Ralph Lucero, Applicant – Mayor Barraza**

103 Mayor Barraza: this is an appeal on PZHAC Case #061333 for Ralph Lucero the applicant. I think his son  
104 Anthony is here to represent him. We have Jerry Nevarez representing the Planning and Zoning

105 commissioners. Before you and in your packet, we have – this case was denied by the Planning and Zoning.  
106 Planning and Zoning did deny this case on February 9, 2022. Mr. Lucero did submit on February 16, 2022, a  
107 letter to appeal this case and this is the case we have before us. We have included documentation as to why  
108 Planning and Zoning denied this case. And per our ordinance 18.06.160 an appeal from a zoning decision of  
109 the Planning and Zoning and Historical Appropriateness Commission. Under C – it is up to the Board of  
110 Trustees to determine that the order or determination or any part thereof of the Planning and Zoning and  
111 Historical Appropriateness Commission is unlawful or unreasonable. The Board of Trustees may make an  
112 appropriate change in any such order or determination. The Board of Trustees shall act on the appeal within  
113 40 days after the Notice of Appeal was filed. We have met that deadline. In the letter – when an appeal alleges  
114 that there is an error in any order, requirement, decision or determination by the Planning and Zoning and  
115 Historical Appropriateness Commission or an official or committee thereof, in the exercise of its power and  
116 duties the Board of Trustees by a two-thirds vote of all of its members may authorize in appropriate cases and  
117 subject to appropriate conditions and safeguards, special exceptions to the terms of the zoning ordinance or  
118 resolution which are not contrary to the public interest. Where, owing to special conditions, a literal  
119 enforcement of the zoning ordinance will result in unnecessary hardship and so that the spirit of the zoning  
120 ordinance is observed, and substantial justice done or in conformity with Sections 3.21.1 through 3.21.14  
121 NMSA 1978. Reverse any order, requirement, decision or determination of the planning, zoning and historical  
122 appropriateness commission, or determination of the planning, zoning, and historical appropriateness  
123 commission, or official or committee thereof. In reviewing Mr. Lucero’s letter, we did meet the deadline of  
124 the 40 days for us to hear the appeal. In the letter there is no, he did not state the reason why he wanted to  
125 appeal the case other than he wanted to appeal the case. And we have attached Mr. Lucero’s letter probably in  
126 the minutes. This case had come before the planning and zoning back in June, 2021. It was denied by  
127 planning and zoning; it went to the Board of Trustees on July 12, 2021. It was denied by the Board of  
128 Trustees. In the discussion of the planning and zoning as it came forth to P&Z they mentioned the  
129 Comprehension Plan. We did include in your packet the Comprehensive Plan where it talks about community  
130 comments. It states there let’s keep commercial development to its existing zones. Other areas as residential  
131 but no apartments or condos. Achieving the preferred land use vision. And again, it does not support much  
132 growth in term of rentals. I hope everyone has had an opportunity to review read your packets, so I don’t have  
133 to read the whole thing. And the other is, I received, actually Friday, a copy of the petition that was sent by  
134 residents and signed by residents and she can read that. Through our petition, our families are requesting that  
135 something be done to keep our town from turning into the new Santa Fe of southern New Mexico. We are not  
136 talking about the art culture or Indian influence, but about local family who have inherited their homes from  
137 parents and grandparents only to be unable to keep them due to the changes brought about by the building of  
138 apartments or rentals in our historic neighborhoods. We do not want to have to leave our homes because of the  
139 transient culture that will soon be taking over our town. We love Mesilla and our families have lived here for  
140 generations, but these transient properties such as apartments and rentals have started to change the face of  
141 Mesilla which is historic and small town and where we know and talk to our neighbors. We welcome  
142 permanent residents who want to become a part of our neighborhoods and join in our culture and history  
143 without changing it. Please look into the ordinances allowing apartments and other rentals to be built in our  
144 neighborhoods before it is too late. Let us stop the building of these apartments and rentals before we lose the  
145 ambience of our town. So I have included all this information for you hopefully to make a decision and  
146 basically in the past we have allowed the applicant and planning and zoning to defend their stance but as I was  
147 reading in the ordinance basically the Board of Trustees are to get the documentation to make their decision  
148 and I would like to hear from board how you would like to proceed.

149  
150 Mayor Pro Tem Johnson-Burick: I just have a couple of questions. So this case came in front of us on June  
151 10, 2021, for special meeting, we had a Public Hearing regarding the same situation. The Public Hearing back  
152 then, the permit put in, for two detached dwelling units. Detached dwelling units the applicant made it very  
153 clear that it was for rental properties, duplex, apartments. Planning and Zoning denied this case 4-0. So they  
154 appealed it to us, we denied it, I think it was 2-1, just us three here. So why is it coming, so then the permit  
155 last time when they, sorry struggling everybody it’s been a long Monday. When they redid the permit, they  
156 had it that two single story family dwellings.

157  
158 Mayor Barraza: it was the same

159

160 Mayor Pro Tem Johnson-Burick: So now they are changing the permit-ok, so going back to that,  
161 Commissioner Salas isn't here; that he voted yes, this time around, whereas last time he stated in the minutes  
162 that he felt it would affect the development zone. And questioned did not meet, wait, felt this construction  
163 would affect the development zone. So all the commissioners did not support it back then so then they bring it  
164 back, the applicant brings it back again, two commissioners, one is new, supports it and the other one that was  
165 here last year does not support it. So I guess without Salas being here Commissioner Nevarez can answer, that  
166 is why the vote changed and so, I guess we're just bring it back again. Are we going to do this every year?  
167

168 Mayor Barraza: Okay, So I can answer part of your questions on this. You are correct on the timeline as to  
169 what was presented. The only difference that I can see what was presented this time was there was an  
170 architectural style designated to the building. Other than that it was identical, same plans and the same use for  
171 two rentals. I understand, I did sit in on that Planning and Zoning meeting since at that time we did not have a  
172 Community Development Coordinator and so therefore I was doing that. Basically Mr. Salas feels this is  
173 something the board needs to address, not necessarily the Planning and Zoning. Unless Mr. Nevarez you can  
174 add to that.  
175

176 Commissioner Nevarez: Do you want an overall?  
177

178 Mayor Barraza: Just that part of it.  
179

180 Commissioner Nevarez: Mr. Salas.  
181

182 Mayor Pro Tem Johnson-Burick: Isn't it that Planning and Zoning job to address this before it comes to us?  
183

184 Mayor Barraza: Correct  
185

186 Commissioner Nevarez: It is the responsibility of the Planning and Zoning to review these items before they  
187 come to the trustees, and make a good faith effort, to vote on that. I was kinda taken by surprise by  
188 Commissioner Salas changing the vote because he had voted no the last time. There was a contradicted zoning  
189 development around there. You go out there, many times you're told at these meetings, they're expanding in  
190 that vicinity, and you can see. We are talking about the historical district, the core where our heart is, actually.  
191 Last time Commissioner Salas voted no because of the zoning. This time around he, I was there, and you were  
192 there, the reason he gave, actually he stated this could go either way, quote unquote.  
193

194 Mayor Barraza: right  
195

196 Commissioner Nevarez: before he voted yes. Because he felt, he still kinda believed, yea, this is a zoning  
197 development contradiction, sort of a contradicting the zoning. I could not understand that it could go either  
198 way. So that is what I am here to report as I witnessed that.  
199

200 Mayor Pro Tem Johnson-Burick: Thank you for that insight. Because I, obviously I wasn't there as I was just  
201 curious as to how that came about, and his decision changed. Thank you, Mr. Nevarez. I do not have anymore  
202 questions at this time.  
203

204 Trustee Merrick: So, is it in the correct zone or is it not?  
205

206 Commissioner Nevarez: It is in the Historic District, if you look, I use the guidance of the Yguado Plan and  
207 the Comprehensive Plan.  
208

209 Trustee Merrick: I looked at both  
210

211 Commissioner Nevarez: Because the language in the Yguado Plan .... Constitutes the development zone. And  
212 so, the plan, Comprehensive Plan calls for appropriate .... land use development in Mesilla. So you are talking  
213 about historic district. I look at the responsibility very seriously. Do we want preserve Mesilla? It talks about  
214 preservation that you have to follow.  
215

216 Trustee Merrick: Okay, and around it there is nothing like it, there are only single-family homes, is that the  
217 issue?  
218  
219 Commissioner Nevarez: There are single-family homes, there are some apartments. If there were bad  
220 judgements in the past, we want to perpetuate. That's the decision the trustees have to make. This is where we  
221 are now, this is the second time around. Both times it has not made through Planning and Zoning. I stand for  
222 further questions.  
223  
224 Mayor Barraza: Thank you. Any more questions, Trustee Merrick? Trustee Garcia  
225  
226 Trustee Garcia: I actually have several. One, we all have to vote, correct Mayor?  
227  
228 Mayor Barraza: I may have to recuse myself, probably recuse myself just because I sat at the Planning and  
229 Zoning and heard the information prior to you all.  
230  
231 Trustee Garcia: So, we have to have three yes's or four yes's or three no's, whatever it is.  
232  
233 Mayor Barraza: Rani? Two-thirds of what is present or the entire board?  
234  
235 Ms. Bush: I is not sure.  
236  
237 Mayor Barraza: Okay because it says two-third of all its members.  
238  
239 Mayor Pro Tem Johnson-Burick: That is what we did the last time, it is in the minutes.  
240  
241 Trustee Garcia: Okay I understand that we had this, but I understand we addressed as well too. The ordinance  
242 got changed, because the previous ordinance stated how many dwellings can they have before we changed the  
243 ordinance. So have many dwellings could each person have before the ordinance got changed.  
244  
245 Mayor Barraza: State that again.  
246  
247 Trustee Garcia: So, before we changed the ordinance how many dwellings can each...  
248  
249 Mayor Barraza: Before we changed the ordinance it was for every 6,000 square feet, one unit.  
250  
251 Trustee Garcia: Okay, one unit. So, we changed it, expanded to 8,000 so we did address this and allowing  
252 two. So, we did what the Comprehensive Plan stated we have to minimize it, so we did. The ordinance got  
253 changed, we updated everything. We did address this, and we did address the Comprehensive Plan. Am I  
254 right to say that or did I read this wrong? I'm just curious. Am I right or wrong? How many square footage is  
255 this anyway?  
256  
257 Mayor Barraza: 16,000 square feet  
258  
259 Trustee Garcia: The ordinance says 8,000 square feet, so he can have two. And Commissioner Nevarez said  
260 there is apartments in that area, correct Commissioner Nevarez?  
261  
262 Commissioner Nevarez: That's correct  
263  
264 Trustee Garcia: So, you did quite answer Trustee Merrick's question, is this in the development zone or not.  
265  
266 Mayor Barraza: I think Trustee Nevarez did answer her.  
267  
268 Commissioner Nevarez: If you look at the historic zone surrounded by Calle de Sur, Calle de Norte, Calle de  
269 Oeste, Highway 28. There are apartments but was it in best judgement at that time, I do not know when they  
270 were built. But you want to perpetuate that as we move forward. Do we want to preserve Mesilla and the  
271 ambiance it has created or do you want to change it as that is the decision before us.

272  
273 Trustee Garcia: We preserved it by expanding the square footage by moving it up to 8,000 square feet.  
274  
275 Commissioner Nevarez: Not referring to the apartments beyond....  
276  
277 Mayor Barraza: Trustee Garcia, you need to address that to me.  
278  
279 Trustee Garcia: The Green Belt says we should build out toward that way, out University. It should be  
280 University on the Comprehensive Plan. That is Calle de Sur. So, we are building out. It is the same thing.  
281  
282 Mayor Barraza: The Green Belt is RF.  
283  
284 Trustee Garcia: So, that's basically what I have to say.  
285  
286 Mayor Pro Tem Johnson-Burick: So, I'm thinking the same purpose, I guess I should address this to Mr.  
287 Lucero. It is still going to rentals and duplexes everything we voted against in the past and it's the same plan  
288 that makes it look like apartments and duplexes. The wording has just changed.  
289  
290 Mayor Barraza: The wording has not changed; it has always been two single dwellings. It is not a duplex, in  
291 her opinion a duplex is attached, these are two dwellings on their own. Correct, Mr. Lucero.  
292  
293 Mr. Lucero: He never really attached them; I do not know how the apartment came about maybe Larry. We  
294 always put them as single-family dwellings.  
295  
296 Mayor Barraza: For rent  
297  
298 Mr. Lucero: yes. Single-family units, I don't know how the apartments came into play. I think he just  
299 assumed; my family owns several apartments in that area. But there are single family homes but there are also  
300 apartments whether they're duplexes or single units that are detached. It is a mix; almost 50/50.  
301  
302 Mayor Pro Tem Johnson-Burick: I am familiar with the area, and I do realize there are duplexes around but as  
303 Commissioner stated these were all done prior to the ordinance changing when we changed it. And again, I  
304 look at the Comprehensive Plan and Yguado Plan which we changed to address this issue. Listening to the  
305 residents in the development zone, I don't know if this is going to mix in with the area, I believe its to the west  
306 of the property.  
307  
308 Mr. Lucero: So being that there is not a full board, I would like to pull it again. So, every time I've come out  
309 here there's never been a full board. I've never had that fair opportunity.  
310  
311 Mayor Barraza: So unfortunately, I didn't expect a person to not be here, so we are here to hear an appeal. If  
312 you pull it is revoked; you withdraw your appeal. This board is here to hear your appeal so that is what we are  
313 going to do.  
314  
315 Mr. Lucero: Being that your brought up the Comprehensive Plan, and I tried to familiarize myself with what is  
316 stated in there and I created a short list of some of those things. Some of the things my family is trying to do is  
317 provide affordable housing which is greatly outlined throughout the plan. Another thing that was pointed out  
318 was the town's population was aging, no offense. Some of these whether you call them single-family  
319 dwellings, apartments, houses, whatever – a lot of those family interact with each other. They are a part of the  
320 community, they send their children to Mesilla Elementary, Mesilla Park, RGPI, local schools. We are trying  
321 to address that concern, the aging population, by providing housing which could bring in new families whether  
322 they are renters or they own the property; it doesn't really matter. I know that small amount of the land is  
323 available for new residential development, farmers what to hold on to their property. But you know, like I  
324 mentioned at the last meeting it is not very viable. That lot only has 16 trees, it is not like we are making really  
325 much off them, we are actually losing money. We are paying more in water rates than what we are getting  
326 from the pecans. The fact that my father had to drill a well, a substantial amount of money that we had to  
327 invest, and we really did not get anything. In there, you guys talked about land percentages, single-family



328 dwellings, primarily are residential. The next two are higher are the orchards and the farmland. In the  
329 Comprehensive Plan you talk about the need for building more houses to attract people that are either not from  
330 out of state or local whether it's the family that own the land and they passed it on to their family. That is what  
331 we are trying to do, whether my brother or his son lives in them, we are trying to pass it on. No offense to  
332 anybody out of state wanting to come into Mesilla. We are trying to keep it in the family. One of the goals  
333 that was outlined in the Comprehensive Plan was to ensure that all current and future residents of all income  
334 level have access to durable quality housing. That is what we are trying to provide. We are not building  
335 \$500/\$600-million-dollar homes on that lot. We are trying to build single-family dwellings units that are  
336 affordable. We do meet the open space requirements, you talked about the 8,000 being reduced to 6,000. We  
337 would be able to put two units on that lot which we followed. We are trying to enhance the mobility of the  
338 areas so more homeowners can purchase these. I know another thing that was brought up, what is your name?  
339

340 Ms. Maya: Gloria  
341

342 Mr. Lucero: At the last time, the traffic that could be caused by two units being built there. Calle de Sur is a  
343 feeder street so obviously I don't think there is going a whole lot of impact by adding two additional more  
344 units. That is really it, I am trying to plead my case because the last couple of times I've been out here there  
345 wasn't a full board and I felt that part was unfair. I know sometimes, and I see it a lot especially in the  
346 construction industry. Sometimes our own feelings or judgements play into some of these things. All I'm  
347 asking is a fair yes or no rule, that's it. Put your feelings aside whatever it maybe, allow us that fair rule and  
348 that is why I was asking for it to be postponed.  
349

350 Mayor Barraza: Mr. Lucero, I have a quick question. I remember Cynthia mention to me that you were going  
351 to provide us documentation about the pervious, about the space, because I think our ordinance is 60/40.  
352

353 Mr. Lucero: I did  
354

355 Mayor Barraza: What was it? She did not receive it.  
356

357 Mr. Lucero: It was hand delivered; a full set of plans.  
358

359 Mayor Barraza: She did not receive it; do you remember what it was off the top of your head.  
360

361 Mr. Lucero: It showed the calculations. It exceeded almost 80%. The two units are only 1,200 square feet.  
362 There is 1,600 square feet total on the lot.  
363

364 Mayor Barraza: And with the parking and all  
365

366 Mr. Lucero: Yes, ma'am  
367

368 Mayor Barraza: Thank you. Any questions, Mayor Pro Tem Johnson-Burick?  
369

370 Mayor Pro Tem Johnson-Burick: Just a couple of questions. I certainly appreciate Mr. Lucero taking the time  
371 to read the Comprehensive Plan. And I certainly empathize and understand the situation but again just  
372 referring back, and in fact you just called them units, and you know that brought to mind my concerns with the  
373 traffic in that area. Going back to the reason I had decline to support it last time based on those same decisions  
374 that I made and things I said ultimately, I am going to have to continue, you know, to not support it this time  
375 because of those concerns. Thank you, Madam Mayor.  
376

377 Mayor Barraza: Thank you, Mayor Pro Tem. Any more questions? Trustee Garcia.  
378

379 Trustee Garcia: I know it's an appeal, can we get legal opinion on it.  
380

381 Mayor Barraza: No.  
382

383 Trustee Garcia: Why not?

384  
385 Mayor Barraza: Why do you wait until the appeal to get legal opinion?  
386  
387 Trustee Garcia: Because we just got it in front of us. We have to see every case as if its brand new. So, why  
388 can't we get legal opinion on it, you guys did it before.  
389  
390 Mayor Barraza: On an appeal?  
391  
392 Trustee Garcia: I don't know if it was an appeal, that's why she's asking why can't we get legal opinion on it.  
393 I'm just pissed.  
394  
395 Mayor Barraza: I would rather we just move... I feel we've held up Mr. Lucero up quite a long time. Is it  
396 going to change anybody's mind, the legal opinion?  
397  
398 Trustee Garcia: We could of put it on the last, to be fair to him. He emailed us February 16<sup>th</sup>, we had a  
399 meeting February twenty-something and it wasn't on there.  
400  
401 Mayor Barraza: That is correct. We had up to 40-days  
402  
403 Trustee Garcia: Right. We're pushing it up to the last minute, just to be fair to him too.  
404  
405 Mayor Barraza: You received your packet on Thursday evening.  
406  
407 Trustee Garcia: Thursday evening. Right, Right- But he sent it on the 15<sup>th</sup> so we had plenty of time to put it  
408 on the 28<sup>th</sup> meeting.  
409  
410 Mayor Barraza: We didn't because we are short staffed as you are aware. And we had to get, we were trying  
411 to get caught up on all the cases. We heard this case on February 9<sup>th</sup>, and I think we had like 20 cases at that  
412 time. We had to make sure we had all our documentation to the Board of Trustees to make decisions.  
413  
414 Trustee Garcia: We've done this before, that's why I'm just curious why we can't get legal opinion, that's  
415 why I'm asking. Why can't we?  
416  
417 Mayor Barraza: What would be your questions?  
418  
419 Trustee Garcia: Ask him is he in the right or is he in the wrong.  
420  
421 Mayor Barraza: I think that is what the Planning and Zoning decided on and that's.....So are we questioning  
422 the decision of the Planning and Zoning? Is that what you want me to take to the attorney, that... the decision  
423 of the Planning and Zoning.  
424  
425 Trustee Garcia: Yea. It was a 2/2 vote and Davie, Commissioner Salas changed his opinion. I know, I  
426 understand Commissioner Nevarez spoke for him on his behalf. I would take it to legal, to see is he in the  
427 right or is he in the wrong, legal opinion.  
428  
429 Mayor Pro Tem Johnson-Burick: Madam Mayor...Trustee Garcia, I appreciate that thought, you know, if we  
430 had more time, I think at this point we just need to take a vote because I don't know that in my case, my vote is  
431 going to change based on what Mr. Cervantes says.  
432  
433 Inaubible  
434  
435 Mayor Barraza: Yea, let me just read this. I would say no, I think we need to move forward with this appeal.  
436 I agree with Mayor Pro Tem Johnson-Burick that Mr. Lucero heard this on February 9<sup>th</sup> with the Planning and  
437 Zoning, and we had gone through the process. With that being said....  
438

439 Trustee Garcia: I make a motion to approve appeal on PZHAC Case #061333 for Ralph Lucero, he does meet  
440 the Comprehensive Plan and he does meet the ordinance.

441  
442 **Motion: To approve appeal on PZHAC Case #061333 – Ralph Lucero, Applicant, Moved by Trustee**  
443 **Garcia, Seconded by Trustee Merrick.**

444  
445 **Roll Call Vote:** Motion denied (summary: Yes =2; No=1).

446 Mayor Pro Tem Johnson-Burick No

447 Trustee Garcia Yes

448 Trustee Merrick Yes

449

450 Ms. Maya: Mayor is it...two-thirds, correct

451

452 Mayor Barraza: Yes

453

454 Ms. Maya: Motion passed

455

456 Mayor Barraza: Motion denied

457

458 **b) For Approval: Amended Contract for Danny Garcia – Mayor Barraza**

459 Marshal Salas reviewed amendment to Danny Garcia's contract which includes the use of a town vehicle.

460

461 **Motion: To approve amended contract for Danny Garcia, Moved by Trustee Garcia, Seconded by**  
462 **Mayor Pro Tem Johnson-Burick.**

463

464 **Roll Call Vote:** Motion passed (summary: Yes =3).

465 Mayor Pro Tem Johnson-Burick Yes

466 Trustee Garcia Yes

467 Trustee Merrick Yes

468

469 **c) For Approval: Proposal from Molzen Corbin for Engineering Services for the Plaza**  
470 **Sidewalk Improvement Project (Capital Outlay Fund 89200 – Control Number 21-F2741**  
471 **for \$117,000) – Rod McGillivray**

472 Mr. McGillivray gave an overview of the Plaza Sidewalk Improvement Project.

473

474 **Motion: To approve proposal from Molzen-Corbin for Engineering Services for the Plaza Sidewalk**  
475 **improvement Project (Capital Outlay Fund 89200 – Control Number 21-F2741 for \$117,000), Moved by**  
476 **Trustee Garcia, Seconded by Trustee Merrick.**

477

478 **Roll Call Vote:** Motion passed (summary: Yes =3).

479 Mayor Pro Tem Johnson-Burick Yes

480 Trustee Garcia Yes

481 Trustee Merrick Yes

482

## 483 **8. BOARD OF TRUSTEE COMMITTEE REPORTS**

484 Trustee Garcia: New Mexico Workforce "Zoom" meeting on Friday.

485

486 Trustee Merrick: MPO meeting

487

488 Mayor Pro Tem Johnson-Burick: MPO meeting 2<sup>nd</sup> Wednesday of April

489

490 Mayor Barraza: Staff Meeting/Defensive Driving Course was held March 1<sup>st</sup>; Business Owner meeting March  
491 9<sup>th</sup>; Mercado Vendors meeting March 10<sup>th</sup>. Architectural Style Committee meeting (Mr. Padilla) March 7<sup>th</sup>.  
492 Met with Trustee Merrick to review budget process.

493  
494  
495  
496  
497  
498  
499  
500

**9. STAFF REPORTS**

- a) Community Development
- b) Community Programs
- c) Finance Department
- d) Fire Department
- e) Marshal Department
- f) Public Works Department

501  
502

**10. BOARD OF TRUSTEE/STAFF COMMENTS**

503 Ms. Bush stated she is excited to be here and will be meeting with the Department Heads.

504  
505

Mr. McGillivary stated Colonia application has been submitted

506  
507

Mr. Klebansky stated he is available when needed.

508  
509

Ms. Bush thanked Ms. Maya for holding up the fort, she really needs recognition for that.

510  
511

Trustee Merrick read letter regarding comments made at Business Owners meeting. Mr. Lucero is trying to keep his family together and that is why she made the decision she made. Her grandparents also have rentals which sustains their family. She moved to Mesilla and is investing in Mesilla. She wants to ensure that they are protecting Mesilla's history. We need to figure out a way to work together. She felt she was ramrodded at the Business Owner meeting. Many cannot sustain a life in Mesilla, so they are not coming back.

512  
513  
514  
515  
516

Trustee Garcia stated she did not know about the meeting, would appreciate being notified. She thanked Ms. Maya for holding up the fort. She stated that Ms. Stoechner-Hernandez lost her father and to keep her in their prayers.

517  
518  
519  
520

Mayor Pro Tem Johnson-Burick thanked Ms. Maya for all her hard work not just in times when we are short staffed but constantly and endlessly. She is so devoted to the town. Everyone is appreciated. Thanked the Mayor for juggling all those hats. Thanked Trustee Merrick for her passion for the town that we all share. She welcomed Ms. Bush and Mr. Padilla to the Town of Mesilla.

521  
522  
523  
524  
525

Trustee Merrick stated she listened but when they talk about her family that is a different ballgame.

526  
527  
528

Mayor Barraza stated she has served the town since 1995 and decisions are never easy to make. She has learned so much while serving these 20 years. People are very vocal during meetings. We do what is right for the town which may not be popular decisions. The board respects each other's decisions which is the key to working together. I may not agree but I listen to the residents. Asked everyone to keep Ms. Stoechner-Hernandez in their prayers. We will be meeting with the Business Owners on a quarterly basis. She was disappointed with the outcome of the legislative session. Senators had \$3.5 million dollars in Capital Outlay, Representatives had \$2 million dollars to distribute. Mesilla received \$50,000 from Senator Cervantes for the Public Safety Building, \$40,000 from Senator Diamond for admin vehicles, \$300,000 from Senator Hamlen; \$50,000 for Mesilla fire hydrants and \$250,000 for the Public Safety Building, \$50,000 from Representative Cadena for fire hydrants. All paperwork was submitted to the legislators, next year we are going to take a stronger approach.

529  
530  
531  
532  
533  
534  
535  
536  
537  
538  
539

Trustee Merrick stated she had spoken to Senator Diamond who stated no one reached out to her.

541  
542 Mayor Barraza stated Mr. Armijo could not get our legislators on the same page. Due to redistricting, there  
543 will be new legislators.  
544  
545 Trustee Garcia recommended reaching out and inviting them to meetings and town events.  
546  
547 Mayor Barraza stated Ms. Bush will coordinate with Ms. Sellers in making information available.  
548 Recommends starting earlier on ICIP. She will be out of town until March 27<sup>th</sup> but will be available by phone.  
549  
550 Mr. Whited reviewed status.  
551  
552 Trustee Garcia thanked Mr. Whited for attending the Architectural Style Committee meetings and Mr.  
553 McGillivray for his work with Las Colonias.

554  
555 **11. ADJOURNMENT**

556 **The Town of Mesilla Trustees unanimously agreed to adjourn the meeting. (Summary: Yes-4).**

557  
558 **MEETING ADJOURNED AT 7:26 P.M.**

559  
560 **APPROVED THIS 28th DAY OF MARCH, 2022.**

561  
562  
563  
564 \_\_\_\_\_  
565 **Nora L. Barraza**  
566 **Mayor**

567  
568 **ATTEST:**

569  
570  
571 \_\_\_\_\_  
572 **Rani Bush**  
573 **Town Clerk/Treasurer**

# Town of Mesilla, New Mexico

BOARD OF TRUSTEES (BOT)  
TOWN OF MESILLA REGULAR MEETING  
MONDAY, MARCH 28, 2022, 6:00 P.M.

MINUTES

**TRUSTEES:** Nora Barraza, Mayor  
Stephanie Johnson-Burick, Mayor Pro Tem  
Bivian Cadena, Trustee  
Veronica Garcia, Trustee  
Adrianna Merrick, Trustee

**STAFF:** Rani Bush, Town Clerk/Treasurer  
Kevin Hoban, Fire Chief  
Rod McGillivray, Public Works Director  
Joe Padilla, Community Development Coordinator  
Enrique Salas, Marshal  
Gloria Maya, Recorder

**PUBLIC:** Susan Krueger                      Hugo Costa  
Lisa Costa                              Russell Hernandez  
Anthony Lucero                      Ralph Lucero  
D. Salas                                  Natalie Ogas  
George Klebansky

**1. PLEDGE OF ALLEGIANCE**

Mayor Barraza led the Pledge of Allegiance.

**2. ROLL CALL & DETERMINATION OF A QUORUM**

**Roll Call.**

**Present:** Mayor Barraza, Mayor Pro Tem Johnson-Burick, Trustee Cadena, Trustee Garcia, Trustee Merrick.

**3. CHANGES TO THE AGENDA & APPROVAL**

Trustee Garcia requested postponing item 6 a) BOT Minutes as they are not per verbatim as requested and item 7 a) until the town attorney is present.

Mayor Barraza asked for section so it can be rectified.

Trustee Garcia responded at the end she asked if it had been approved and Ms. Maya responded yes. She stated she would send the recording to Ms. Maya.

Mayor Barraza asked if Trustee Garcia had requested the recording.

Trustee Garcia responded someone else requested the recording, but they got the whole thing.

54 Mayor Barraza asked who received it.  
55  
56 Trustee Garcia responded they received an email with the recording.  
57 Ms. Bush stated she sent the recording to Mr. Lucero and must have sent it to everyone on the list.  
58

59 **Motion: To approve agenda as amended, Moved by Trustee Garcia, Seconded by Trustee Merrick.**  
60

61 **Roll Call Vote:** Motion passed (summary: Yes =4).

62 Mayor Pro Tem Johnson-Burick Yes  
63 Trustee Cadena Yes  
64 Trustee Garcia Yes  
65 Trustee Merrick Yes  
66

67 **4. PUBLIC INPUT – The public is invited to address the Board for up to 3 minutes.**

68 Mr. A. Lucero read letter regarding his appeal.  
69

70 Mr. Hernandez gave his time to Mr. Lucero.  
71

72 Mr. R. Lucero read letter regarding his appeal.  
73

74 Ms. Krueger stated the Comprehensive Plan and the Yguado Plan are just plans, not ordinances. The  
75 applicant should be allowed to postpone their case if there is not a full board. She asked if the mayor  
76 must recuse herself would that affect the 2/3 number.  
77

78 **5. PRESENTATION**

79 a) National Public Safety Telecommunications Week, April 10 - 16

80 Mr. Costa read proclamation for National Public Safety Telecommunications Week, April 10-16. He  
81 stated it is an honor to receive the proclamation from Town of Mesilla.  
82

83 Mayor Barraza stated she appreciates what they do for Dona Ana County.  
84

85 **6. APPROVAL OF CONSENT AGENDA:** (The Board will be asked to approve by one motion the  
86 following items of recurring or routine business. The Consent Agenda is marked with an asterisk \*)

87 **Motion: To approve consent agenda as amended, Moved by Mayor Pro Tem Johnson-Burick,**  
88 **Seconded by Trustee Garcia.**  
89

90 **Roll Call Vote:** Motion passed (summary: Yes =4).

91 Mayor Pro Tem Johnson-Burick Yes  
92 Trustee Cadena Yes  
93 Trustee Garcia Yes  
94 Trustee Merrick Yes  
95

96 a) **\*BOT MINUTES** – Minutes of Regular Meeting, March 14, 2022. *Postponed*

97 b) **\*PZHAC Case #061102 – 2785 Boldt**, submitted by Steven Sypher for Barncastle  
98 Construction to renew permit to complete remodel of interior framing and stucco.  
99 **Zoned: Historic Residential (HR).** *Approved by consent agenda*

100 c) **\*PZHAC Case #061355 - 2481 Calle De Cura**, submitted by Jennie Soltero for Window  
101 World of Las Cruces to remove and replace four (4) windows located in den area of  
102 house, **Zoned: Historic Residential (HR).** *Approved by consent agenda*  
103  
104

105 7. NEW BUSINESS

106 a) *For Discussion:* Appeal Process Postponed

107  
108 b) *For Approval:* CES for Lynco Electric Co. Inc. Proposal for \$116,747.18 dated March  
109 18,2022 for the Mesilla Streetlight Improvement Project – Rod McGillivray

110 Mr. McGillivray gave an overview of the project.

111  
112 **Motion: To approve CES for Lynco Electric Co., Inc. Proposal for \$116,747.18 dated March 18,**  
113 **2022 for the Mesilla Streetlight Improvement Project, Moved by Trustee Garcia, Seconded by**  
114 **Mayor Pro Tem Johnson-Burick.**

115  
116 **Roll Call Vote:** Motion passed (summary: Yes =4).

117 Mayor Pro Tem Johnson-Burick Yes

118 Trustee Cadena Yes

119 Trustee Garcia Yes

120 Trustee Merrick Yes

121  
122 c) *For Approval:* Proposal from Molzen Corbin for Design Services totaling \$47,008.00 for  
123 Calle de Picacho Roadway Improvements – Rod McGillivray

124 Mr. McGillivray gave an overview of the project.

125  
126 **Motion: To approve proposal from Molzen-Corbin for Design Services totaling \$47,008.00 for Calle**  
127 **de Picacho Roadway Improvements, Moved by Moved by Mayor Pro Tem Johnson-Burick,**  
128 **Seconded by Mayor Pro Tem Johnson-Burick.**

129  
130 **Roll Call Vote:** Motion passed (summary: Yes =4).

131 Mayor Pro Tem Johnson-Burick Yes

132 Trustee Cadena Yes

133 Trustee Garcia Yes

134 Trustee Merrick Yes

135  
136 d) *For Approval:* proposal from Molzen Corbin for Design Services totaling \$29,300.00 for  
137 Calle de Picacho Drainage Improvements Project – Rod McGillivray

138 Mr. McGillivray gave an overview of the project.

139  
140 **Motion: To approve proposal from Molzen-Corbin for Design Services totaling \$29,300.00 for Calle**  
141 **de Picacho Drainage Improvements Project, Moved by Mayor Pro Tem Johnson-Burick, Seconded**  
142 **by Trustee Garcia.**

143  
144 Trustee Garcia asked about the timeframe for completion of the project, so we do not lose funding.

145  
146 Mr. McGillivray responded project must be completed by June 2025.

147  
148 **Roll Call Vote:** Motion passed (summary: Yes =4).

149 Mayor Pro Tem Johnson-Burick Yes

150 Trustee Cadena Yes

151 Trustee Garcia Yes

152 Trustee Merrick Yes



153 **8. BOARD OF TRUSTEE COMMITTEE REPORTS**

154 Trustee Garcia: Architectural Style Committee meeting, next meeting Tuesday, March 29<sup>th</sup>; Work Force  
155 Solution meeting, next meeting in June.

156

157 Mayor Pro Tem Johnson-Burick: MPO will meet on April 13<sup>th</sup>.

158

159 Mayor Barraza: RTD (teleconference) meeting Wednesday, March 23<sup>rd</sup>; SCCOG meeting Friday, March  
160 25<sup>th</sup>.

161

162 **9. BOARD OF TRUSTEE/STAFF COMMENTS**

163 Fire Chief Hoban inaudible

164

165 Marshal Salas inaudible

166

167 Trustee Cadena stated she appreciated the Public Input.

168

169 Trustee Garcia thanked Ms. Bush for reviewing the budget process with the trustees and asked her to look  
170 into the \$110,000 before it is lost. She wants legal opinion to ensure the trustees are correctly following  
171 the appeal process.

172

173 Ms. Bush responded she is looking into it.

174

175 Mayor Pro Tem Johnson-Burick stated it was a wonderful opportunity to represent Mesilla during the  
176 reception for the Secretary of Interior. She thanked Senator Hamlen for the funding she provided the  
177 town.

178

179 Trustee Merrick thanked Ms. Bush for reviewing the budget process. Stated it would help if Mr.  
180 Cervantes would have attended this meeting to answer questions that have come up such as when Trustee  
181 Garcia asked if it was 2/3 and Ms. Maya said motion does pass.

182

183 Mayor Barraza stated Mr. Cervantes will not be available until April; he is not required to attend every  
184 meeting. She will call a Special Meeting if necessary. Encouraged the trustees to bring forth questions  
185 they may have during the MOLI Training. Chapter 18 reviews the appeal process. There will be a  
186 Special Meeting for a Liquor License on Tuesday, April 5<sup>th</sup> at 3:00 p.m. The attendees have been  
187 registered for the MOLI Training and she passed out hotel reservations confirmations. The auditors will  
188 review the FY21 Audit Report, which is being provided to you for your review, at our next BOT meeting.

189

190 Trustee Garcia asked if the April 5<sup>th</sup> meeting could be done by phone or zoom.

191

192 Mayor Barraza responded we are currently not set up for that; Mr. McGillivray is currently in the process  
193 of updating our system. We can a teleconference if she would like to call in.

194

195 Trustee Garcia asked if packets can be made available by Wednesday or Thursday.

196 Ms. Bush responded that is her goal.

197

198 Mayor Barraza stated we are working with Planning and Zoning and the Architectural Style Committee to  
199 get information so that the packets are out by Wednesdays.

200  
201 Trustee Cadena stated she would like to ensure that packets are complete when they are sent out; this is a  
202 process that needs to be worked on. She wants to see that citizens feel they are being treated fairly and  
203 equally. Trustees need to review all pertinent information and material. We need time to do research,  
204 have dialog with citizens, staff and mayor. She recommends staggering the meetings. She wants to come  
205 with full knowledge and understanding of what needs to be voted on. She wants to become familiar with  
206 the code book; put things in priority.

207  
208 Mayor Barraza stated we are trying to streamline the process. It is currently taking to long to process  
209 applications. There are only limited projects that can be administrative approved. Mr. Padilla is ensuring  
210 that all applications have all the required documentation so that it can move forward and not be delayed  
211 because it is sent back. We are now also involving the Fire Marshal in the permit process. The Board of  
212 Trustee only get cases that are in the Historical Residential, Historical Commercial, and Historic General  
213 zones. Ms. Bush and Mr. Padilla are working together on timelines. Once the trustees and Planning and  
214 Zoning become familiar with ordinances, we can accommodate the residents in a timely manner. Town  
215 ordinances and codes are available on the town website, mesillanm.gov.

216

217 **10. ADJOURNMENT**

218

219 **The Town of Mesilla Trustees unanimously agreed to adjourn the meeting. (Summary: Yes-4).**

220

221 **MEETING ADJOURNED AT 6:46 P.M.**

222

223 **APPROVED THIS 11th DAY OF APRIL, 2022.**

224

225

226

227

\_\_\_\_\_  
**Nora L. Barraza**  
**Mayor**

228

229

230

231 **ATTEST:**

232

233

234

\_\_\_\_\_  
**Rani Bush**  
**Town Clerk/Treasurer**

235

236

## BOARD ACTION FORM

### AGENDA DATE

PZHAC: April 04, 2022,

BOT: *APRIL 11, 2022*

**ITEM:** PZHAC Case #061364 – 2043 Calle De Correo, submitted by Alison Tinsley to install a residential rooftop solar system, **Zoned: Historic Residential (HR).**

**BACKGROUND AND ANALYSIS:** This case was reviewed by the Architectural Styles Committee (ASC) it was discussed about panel placement and Height and would it comply with the town code 18.33. it is in the Historic Residential Zone (HR)

Organ Mountain Solar & Electric is proposing an installation of a roof top solar system.

### IMPACT:

- The PZHAC has jurisdiction to recommend approval of the applicant's request for approval of this request to the BOT.
- The applicant has the authority to make an application request to the PZHAC and BOT.
- Due process was provided to the applicant.

Specific findings of fact:

- The proposed work is on applicant's property and not in Town of Mesilla right-of-way.

### ALTERNATIVES:

The Planning, Zoning and Historical Appropriateness Commission (PZHAC) may:

1. Recommend approval of this case with findings stated above.
2. Recommend approval of this case with findings stated above and conditions.
3. Deny the application.

### DEPARTMENT RECOMMENDATIONS:

### SUPPORTING INFORMATION:

- Application
- Plans

**TOWN OF MESILLA  
ZONING APPROVAL**

OFFICIAL USE ONLY:

Case # 061364

Fee \$ 359.50

*Fee \$ 310.00  
Revision = 49.50*

**PERMISSION TO CONDUCT WORK  
OR  
OBTAIN A COMMERCIAL/RESIDENTIAL BUILDING PERMIT FROM CID**

2231 Avenida de Mesilla, P.O. Box 10, Mesilla, NM 88046 (575) 524-3262 ext. 104

CASE NO. \_\_\_\_\_ ZONE: \_\_\_\_\_ CODE: \_\_\_\_\_ APPLICATION DATE: \_\_\_\_\_

Alison Tinsley \_\_\_\_\_ 575-640-3764 \_\_\_\_\_

Name of Property Owner \_\_\_\_\_ Property Owner's Telephone Number \_\_\_\_\_

2043 Calle De Correo Las Cruces NM 88005

Property Owner's Mailing Address City State Zip Code

alisontinsley48@gmail.com

Property Owner's E-mail Address \_\_\_\_\_

Organ Mountain Solar & Electric \_\_\_\_\_

Contractor's Name & Address (If none, indicate Self) \_\_\_\_\_

575-202-9268 03-401215-00-0 394801

Contractor's Telephone Number Contractor's Tax ID Number Contractor's License Number

Address of Proposed Work: 2043 Calle De Correo Las Cruces, NM 88005

Description of Proposed Work: Residential Rooftop Solar Installation

\$ 25,690 \_\_\_\_\_ 3/15/2022 \_\_\_\_\_

Estimated Cost Signature of Applicant Date

Signature of property owner: 

With the exception of administrative approvals, all permit requests must undergo a review process from staff, PZHAC and/or BOT before issuance of a zoning permit. Plan sheets are to be no larger than 11 x 17 inches or shall be submitted electronically.

**FOR OFFICIAL USE ONLY**

PZHAC  Administrative Approval BOT  Approved Date: \_\_\_\_\_

Approved Date: \_\_\_\_\_  Disapproved Date: \_\_\_\_\_

Disapproved Date: \_\_\_\_\_  Approved with Conditions

Approved with conditions

PZHAC APPROVAL REQUIRED: \_\_\_ YES \_\_\_ NO BOT APPROVAL REQUIRED: \_\_\_ YES \_\_\_ NO

CID PERMIT/INSPECTION REQUIRED: \_\_\_ YES \_\_\_ NO \_\_\_ SEE CONDITIONS

CONDITIONS: \_\_\_\_\_

PERMISSION ISSUED/DENIED BY: \_\_\_\_\_ ISSUE DATE: \_\_\_\_\_

**THIS APPLICATION SHALL INCLUDE ALL OF THE FOLLOWING:**

1. Plot plan with legal description to show existing structures, adjoining streets, driveway(s), improvements & setbacks. Verification shall show that the lot was **LEGALLY** subdivided through the Town of Mesilla or that the lot has been in existence prior to February 1972.
2. Site Plan with dimensions and details.
3. Foundation plan with details.
4. Floor plan showing rooms, their uses and dimensions.
5. Cross section of walls
6. Roof and floor framing plan
8. Proof of legal access to the property.
9. Drainage plan.
10. Details of architectural style and color scheme (checklist included for Historical zones) – diagrams and elevations.
11. Proof of sewer service or a copy of septic tank permit; proof of water service (well permit or statement from the Public Utility providing water services).
12. Proof of legal access to the property.
13. Other information as necessary or required by the City Code or Community Development Department (See other side.)

The following are requirements to be included with all building permit applications for new structures or additions to existing structures, as well as other construction or fixtures that will be permanent in nature and affect the appearance or use of the property. (This includes fences, well houses, storage units, metal sheds, photo-voltaic panels that can be seen from the ground, etc.)

### BUILDING PERMIT REQUIREMENTS

A. Completed application, including:

1. Applicant's name
2. Applicant/property owners contact information
3. Physical address of property
4. Description of work to be done, including dimensions of any construction or repairs
5. Value of work to be done
6. Property owner's signature on the application

B. Include all information required in the checklist at the bottom of the application.

C. Additional information required:

---

---

---

---

Note:  
-Special Access Instructions: None.

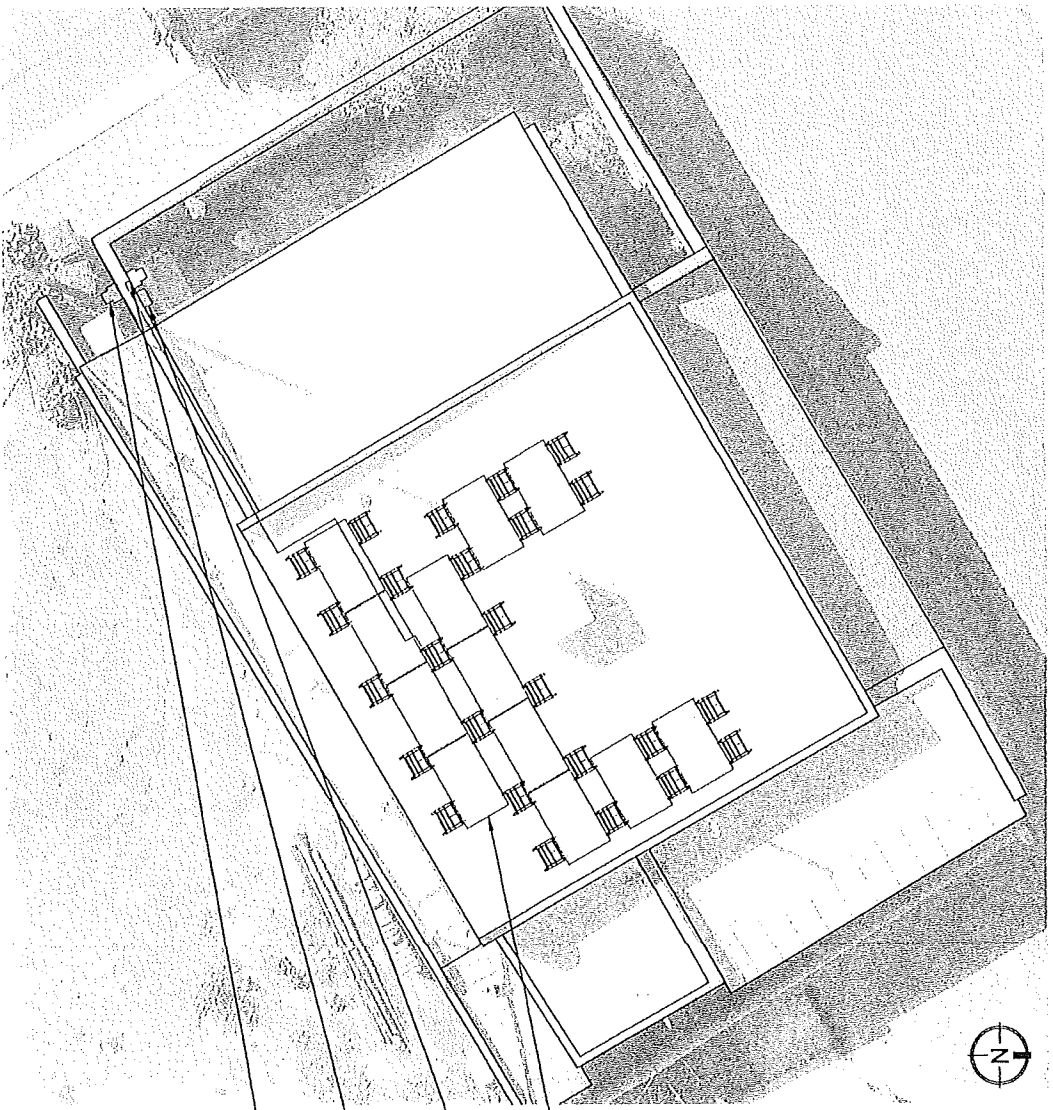

1 Site Plan  
Scale: 1/8" = 1'-0"

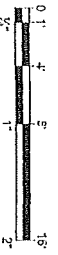

2 Vicinity Map  
Scale: CUSTOM

- Roof Mounted Array  
12 x Panasonic EverVolt Modules  
with Emphase Microinverters
- Existing Main Service Disconnect & Panel  
(Outside)
- Customer Generation AC Disconnect /  
Production Meter / AC Combiner Panel /  
Data Monitoring Unit  
(Outside)
- Existing Utility Meter (Outside)

SHEET NOTES	
1	Exact location of equipment and conduit is subject to minor variations during installation.
2	Estimated annual energy production is based on existing site conditions and the array layout. Annual variations in weather and module degradation will affect production.
3	I approve of this design showing all equipment and locations, and estimated production. Any change to this design may result in delays and additional costs.
Approved By: _____ Date: _____	



**Organ Mountain Solar**  
400 South Compress Road  
Suite D  
Las Cruces, NM 88005  
(575) 288-1792  
NM Electrical Contractor's  
License # 394801

Owner  
**Alison Trinsley**  
Coss Realstate

Utility-Interactive Photovoltaic System  
System Size = 4.44 kWdc  
2043 Calle de Correo  
Mesilla, NM 88045

DESIGNER:  
**Polizois Dallas**

REV	DESCRIPTION	DATE
0	Initial Release	3/3/22

DESIGN SUMMARY	
Number of Modules	12
Module Tilt Angle	10°
Module Azimuth	145°
Average Annual Shading	2.00%
Year 1 Production Estimate	8015 kWh

**SITE PLAN**  
**PV-1.0**

Roof Mounted Array

BoS Location (Exterior Wall)

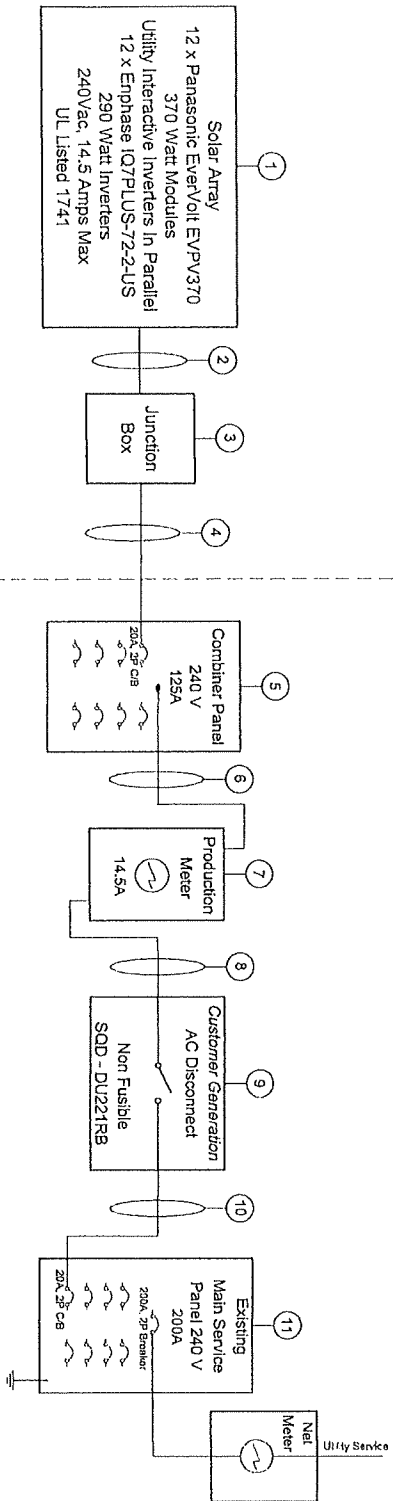

Inverters AC Capacity: 12 x 290 W = 3.48 kWac  
 Array STC Watts: 12 x 370 W = 4.44 kWdc  
 Combined Fault Current: 69.6 Arms; 3 cycles

- Electrical System Notes**
- All electrical components are UL listed where warranted
  - PI System shall be installed in accordance with Article 690 of the 2017 National Electric Code
  - Electrical lugs used with multiple conductors shall be rated for both multiple conductors and circular mil
  - Bond bushings shall be used on concentric and eccentric metal knockouts
  - EMT conduit shall include expansion joints where required
- Grounding Notes**
- A grounding electrode system in accordance with NEC 690.47 and 250.50 through 250.53 and 250.166 shall be provided
  - All grounds shall be connected to the main service ground in the existing Main Service

- Keyed Notes**
- Roof Mounted Array (T<sub>max</sub> = 110 F, T<sub>avg</sub> = 100 F) and 1x #8 AWG bare Cu per rack
  - MicroInverter Conductors, T<sub>C-ER</sub> Cable, 2 x #12 AWG, 90 C wet rated.
  - 1/8" EMT (min) pass-through enclosure for wire transition or equivalent.
  - 1/2" EMT (min) contains 2x #10 AWG THWN-2 (current carrying conductors) and 1x #10 AWG THWN-2 (EGC).
  - 50' AC run at 0.75% Vdrop for #10 AWG THWN-2
  - Emphase IQ Combiner, X-100-201-250-2, NEMA 3R, 125A rated panel with pre-wired IQ Emvay (data monitoring), 1x #8 AWG THWN-2 (neutral) and 1x #8 AWG THWN-2 (EGC).
  - 5' AC run at 0.05% Vdrop for #8 AWG THWN-2
  - Midbank US934XL, NEMA 3R, 100 A meter enclosure.
  - 3/4" Nipple (min) contains 2x #8 AWG THWN-2 (current carrying conductors), 1x #8 AWG THWN-2 (neutral) and 1x #8 AWG THWN-2 (EGC).
  - 5' AC run at 0.05% Vdrop for #8 AWG THWN-2
  - Square D DU221RB, NEMA 3R, 30A rated non fusable disconnect.
  - 3/4" EMT or PVC (min) contains 2x #8 AWG THWN-2 (current carrying conductors), 1x #8 AWG THWN-2 (neutral) and 1x #8 AWG THWN-2 (EGC).
  - 10' AC run at 0.05% Vdrop for #8 AWG THWN-2

- Keyed Notes**
- Existing Load Center with a 200 Amp Bus Bar, a 200 Amp Main Breaker and a new 20 Amp solar back feed CB.

**Organ Mountain Solar & Electric**  
 400 South Compress Road  
 Suite D  
 Las Cruces, NM 88905  
 (575) 288-1792  
 NM Electrical Contractor's  
 License # 394801

**Owner**  
 Alison Tinsley  
 Coss Realstate  
 Utility-Interactive Photovoltaic System  
 System Size = 4.44 kWdc  
 2043 Calle de Correo  
 Mesilla, NM 88045

**DESIGNER**  
 Polizois Dallis

REV	DESCRIPTION	DATE
0	Initial Release	3/3/22

**DESIGN SUMMARY**

Number of Modules	12
Module Tilt Angle	10°
Module Azimuth	145°
Year 1 Production Estimate	8015 kWh

**ONE-LINE DIAGRAM**  
**PV-3.0**



Site

1  
2

R 1: W E ( C P I D ( E L

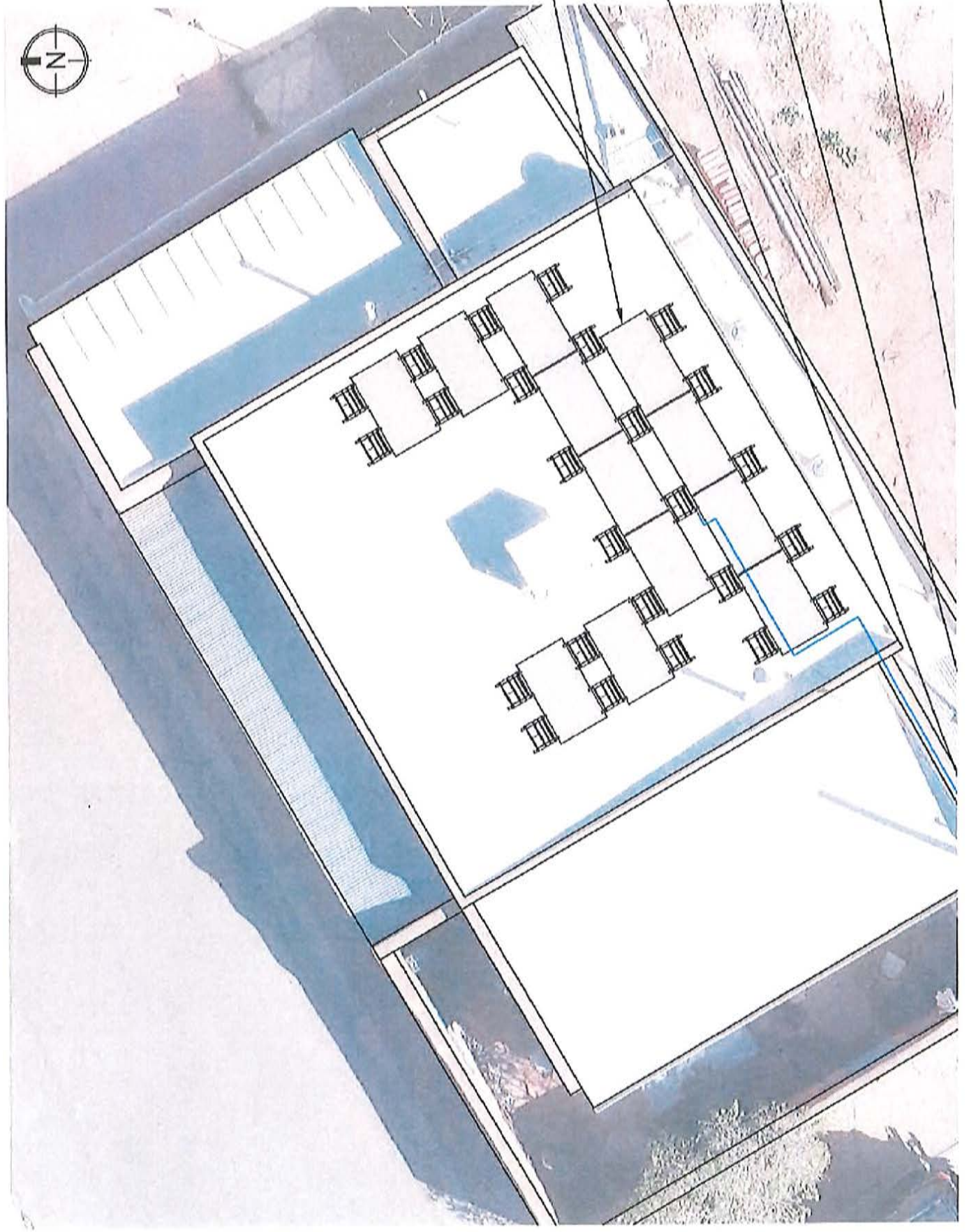

Note:  
-Special Access Instructions: None.



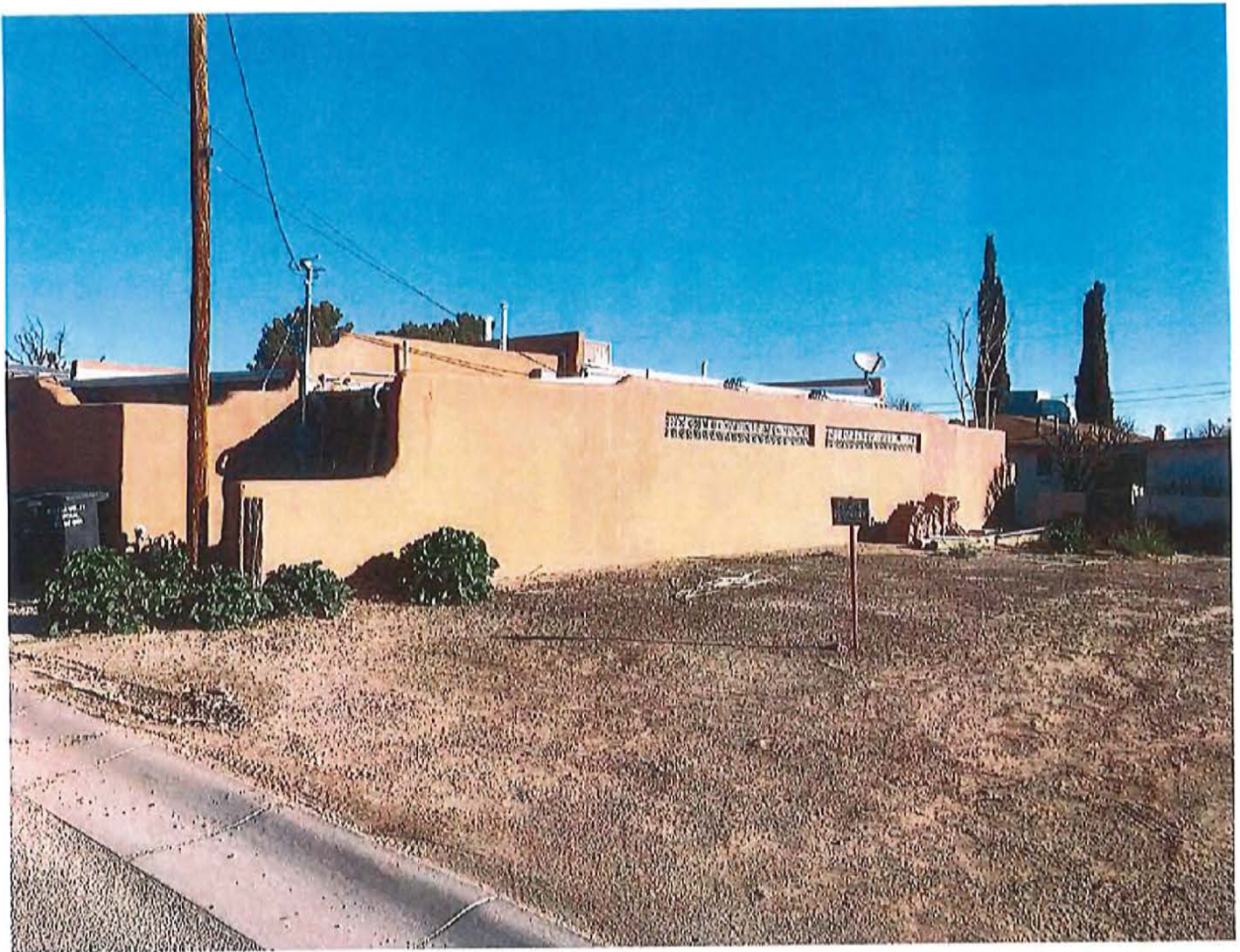

## ACTION FORM

### AGENDA DATE

PZHAC: April 04, 2022,

BOT: *APRIL 11, 2022*

**ITEM:** PZHAC Case #061368 – 2305 Calle De Colon, submitted by Gerard Nevarez to coat exterior of house with elastomeric and clear coat wood on gate, no changes in colors. **Zoned Historic Residential (HR)**

**BACKGROUND AND ANALYSIS:** This case was reviewed by the Architectural Styles Committee (ASC) and had no issues moving it forward

Gerard Nevarez is proposing to coat exterior of house with elastomeric no change to house exterior color and clear coat wood on gate, no changes in colors

### IMPACT:

- The PZHAC has jurisdiction to recommend approval of the applicant's request for approval of this request to the BOT.
- The applicant has the authority to make an application request to the PZHAC and BOT.
- Due process was provided to the applicant.

Specific findings of fact:

- The proposed work is on applicant's property and not in Town of Mesilla right-of-way.

### ALTERNATIVES:

The Planning, Zoning and Historical Appropriateness Commission (PZHAC) may:

1. Recommend approval of this case with findings stated above.
2. Recommend approval of this case with findings stated above and conditions.
3. Deny the application.

### DEPARTMENT RECOMMENDATIONS:

### SUPPORTING INFORMATION:

- Application
- Plans

**TOWN OF MESILLA  
ZONING APPROVAL**

OFFICIAL USE ONLY:

Case # 061368

Fee \$ 129.50

*Permit 10.00  
Review 19.50*

**PERMISSION TO CONDUCT WORK  
OR  
OBTAIN A COMMERCIAL/RESIDENTIAL BUILDING PERMIT FROM CID**

2231 Avenida de Mesilla, P.O. Box 10, Mesilla, NM 88046 (575) 524-3262 ext. 104

CASE NO. \_\_\_\_\_ ZONE: \_\_\_\_\_ CODE: \_\_\_\_\_ APPLICATION DATE: \_\_\_\_\_

Gerard Nevarez 575 642 3938  
Name of Property Owner Property Owner's Telephone Number

PO Box 1102 Mesilla NM 88046  
Property Owner's Mailing Address City State Zip Code

mesilla13@aol.com  
Property Owner's E-mail Address

Josh Krause (Nova) 2706 Claude Dove Dr.  
Contractor's Name & Address (If none, indicate Self)

575.640.0713 \_\_\_\_\_  
Contractor's Telephone Number Contractor's Tax ID Number Contractor's License Number

Address of Proposed Work: 3305 Calle de Colon

Description of Proposed Work: Paint exterior of house with elastomeric. No change from current house exterior color. Clear coat on wood gate & some

\$600 \_\_\_\_\_ 03.18.22 Color  
Estimated Cost Signature of Applicant Date

Signature of property owner: \_\_\_\_\_

With the exception of administrative approvals, all permit requests must undergo a review process from staff, PZHAC and/or BOT before issuance of a zoning permit. **Plan sheets are to be no larger than 11 x 17 inches or shall be submitted electronically.**

**FOR OFFICIAL USE ONLY**

**PZHAC**  Administrative Approval **BOT**  Approved Date: \_\_\_\_\_  
 Approved Date: \_\_\_\_\_  Disapproved Date: \_\_\_\_\_  
 Disapproved Date: \_\_\_\_\_  Approved with Conditions  
 Approved with conditions

PZHAC APPROVAL REQUIRED:  YES  NO BOT APPROVAL REQUIRED:  YES  NO

CID PERMIT/INSPECTION REQUIRED:  YES  NO  SEE CONDITIONS

CONDITIONS: \_\_\_\_\_  
\_\_\_\_\_  
\_\_\_\_\_

PERMISSION ISSUED/DENIED BY: \_\_\_\_\_ ISSUE DATE: \_\_\_\_\_

**THIS APPLICATION SHALL INCLUDE ALL OF THE FOLLOWING:**

1. \_\_\_\_\_ Plot plan with legal description to show existing structures, adjoining streets, driveway(s), improvements & setbacks. Verification shall show that the lot was LEGALLY subdivided through the Town of Mesilla or that the lot has been in existence prior to February 1972.
2. \_\_\_\_\_ Site Plan with dimensions and details.
3. \_\_\_\_\_ Foundation plan with details.
4. \_\_\_\_\_ Floor plan showing rooms, their uses and dimensions.
5. \_\_\_\_\_ Cross section of walls
6. \_\_\_\_\_ Roof and floor framing plan
8. \_\_\_\_\_ Proof of legal access to the property.
9. \_\_\_\_\_ Drainage plan.
10. \_\_\_\_\_ Details of architectural style and color scheme (checklist included for Historical zones) – diagrams and elevations.
11. \_\_\_\_\_ Proof of sewer service or a copy of septic tank permit; proof of water service (well permit or statement from the Public Utility providing water services).
12. \_\_\_\_\_ Proof of legal access to the property.
13. \_\_\_\_\_ Other information as necessary or required by the City Code or Community Development Department (See other side.)

# Gerard Nevarez

## Layer Visibility:

- Roads
- City Limits
- MLS Zones
- Address Labels
- 2014 Aerial Photo
- Parcels



Dona Ana County Assessor's Office | Dona Ana

ACCOUNTNUMBER:	R0400572	PARCELNUMBER:	4006138208035
OWNERNAME:	NEVAREZ GERARD R	MAILADDR1:	PO BOX 1102
CITY:	MESILLA	STATE:	NM
ZIP:	88046-1102	LOT:	
BLOCK:		SUBNAME:	
TRS:	235 1E 36	SITUSADDRS:	2305 CALLE DE COLON
TOTALACRES:	0		

Google Maps 2305 Calle De Colon



Imagery ©2022 Maxar Technologies, U.S. Geological Survey, Map data ©2022 Google 50 ft



### 2305 Calle De Colon

Building

-  Directions
-  Save
-  Nearby
-  Send to your phone
-  Share

 2305 Calle De Colon, Las Cruces, NM 88005

Photos

22805

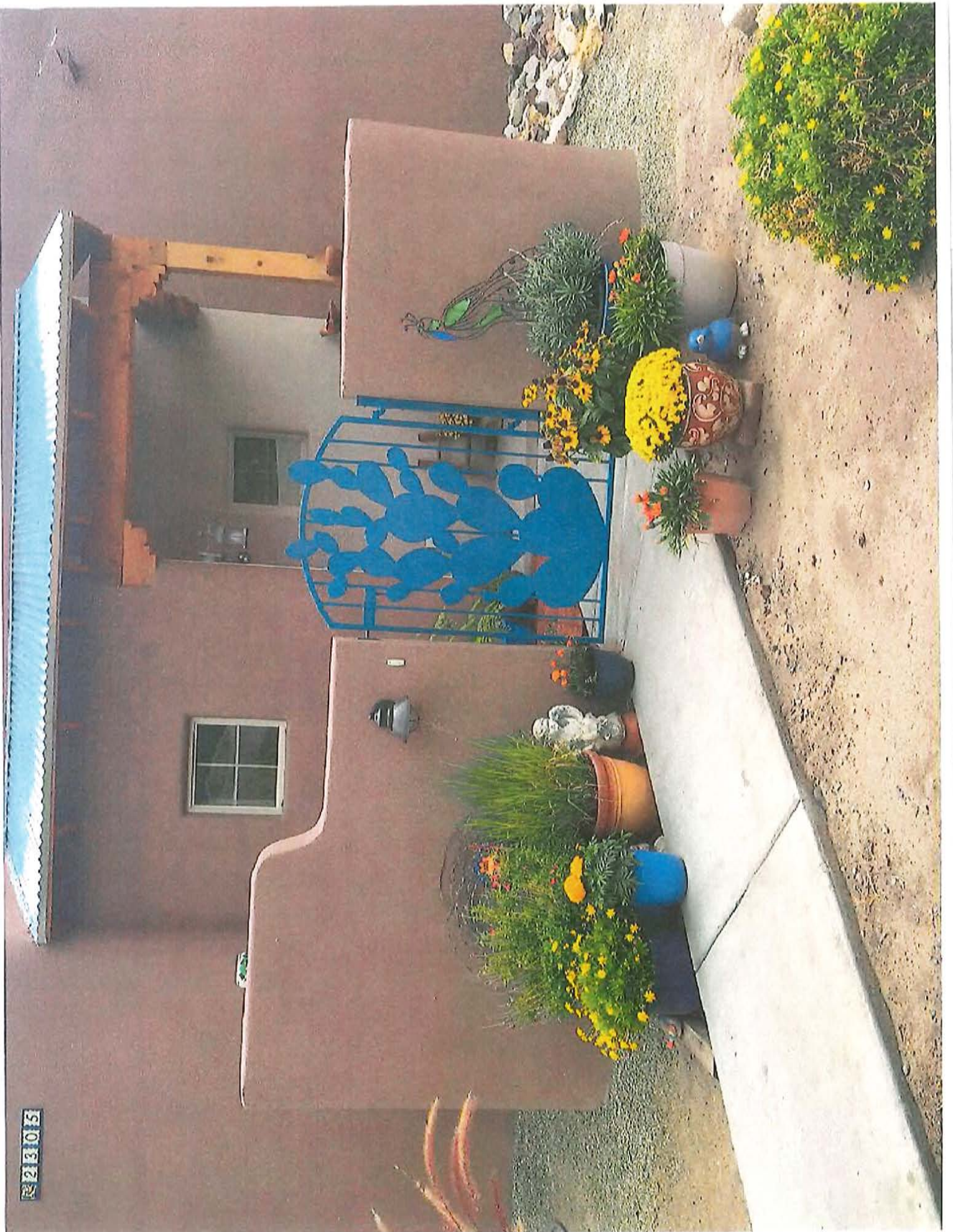

## ACTION FORM

### AGENDA DATE

PZHAC: April 04, 2022,

BOT: *APRIL 11, 2022*

**ITEM:** PZHAC Case #061371 – 331 Capri Arc submitted by Frances Williams to install a ground mounted solar system. **Zoned: R-1**

**BACKGROUND AND ANALYSIS:** Although this property is in the R-1 Zone this case was reviewed by the Architectural Styles Committee (ASC) and had no issues moving it forward

Solar Smart Living LLC is proposing installation of ground mounted solar system, with ten (10) photovoltaic modules. **Zoned: R-1**

### IMPACT:

- The PZHAC has jurisdiction to recommend approval of the applicant's request for approval of this request to the BOT.
- The applicant has the authority to make an application request to the PZHAC and BOT.
- Due process was provided to the applicant.

Specific findings of fact:

- The proposed work is on applicant's property and not in Town of Mesilla right-of-way.

### ALTERNATIVES:

The Planning, Zoning and Historical Appropriateness Commission (PZHAC) may:

1. Recommend approval of this case with findings stated above.
2. Recommend approval of this case with findings stated above and conditions.
3. Deny the application.

### DEPARTMENT RECOMMENDATIONS:

### SUPPORTING INFORMATION:

- Application
- Plans

TOWN OF MESILLA  
ZONING APPROVAL

OFFICIAL USE ONLY:

Case # 061371

Fee \$ 233.00

PERMISSION TO CONDUCT WORK  
OR  
OBTAIN A COMMERCIAL/RESIDENTIAL BUILDING PERMIT FROM CID

Fee 200.00  
Plan 33.00

2231 Avenida de Mesilla, P.O. Box 10, Mesilla, NM 88046 (575) 524-3262 ext. 104

CASE NO. \_\_\_\_\_ ZONE: \_\_\_\_\_ CODE: \_\_\_\_\_ APPLICATION DATE: \_\_\_\_\_

Francis Williams (575) 496-6185  
Name of Property Owner Property Owner's Telephone Number  
331 Capri Arc Las Cruces NM 88005  
Property Owner's Mailing Address City State Zip Code  
frank@mmsu.edu

Property Owner's E-mail Address  
Solar Smart Living, LLC - 108 Ray Ward Pl, Santa Teresa NM 88008 (Applicant: Paulina Olivas)

Contractor's Name & Address (If none, indicate Self)  
(575) 400-2995 3-20375-4488-2 361818  
Contractor's Telephone Number Contractor's Tax ID Number Contractor's License Number

Address of Proposed Work: 331 Capri Arc, Las Cruces NM 88005

Description of Proposed Work: Installation of groundmounted solar system, 10 photovoltaic modules to be installed.

\$ 15,000.00  
Estimated Cost Signature of Applicant Frank Williams Date 3/24/22

Signature of property owner: Frank Williams

With the exception of administrative approvals, all permit requests must undergo a review process from staff, PZHAC and/or BOT before issuance of a zoning permit. Plan sheets are to be no larger than 11 x 17 inches or shall be submitted electronically.

FOR OFFICIAL USE ONLY

PZHAC  Administrative Approval  Approved Date: \_\_\_\_\_  
 Approved Date: \_\_\_\_\_  Disapproved Date: \_\_\_\_\_  
 Disapproved Date: \_\_\_\_\_  Approved with Conditions  
 Approved with conditions

PZHAC APPROVAL REQUIRED: \_\_\_ YES \_\_\_ NO BOT APPROVAL REQUIRED: \_\_\_ YES \_\_\_ NO

CID PERMIT/INSPECTION REQUIRED: \_\_\_ YES \_\_\_ NO \_\_\_ SEE CONDITIONS

CONDITIONS: \_\_\_\_\_

PERMISSION ISSUED/DENIED BY: \_\_\_\_\_ ISSUE DATE: \_\_\_\_\_

THIS APPLICATION SHALL INCLUDE ALL OF THE FOLLOWING:

1. Plot plan with legal description to show existing structures, adjoining streets, driveway(s), improvements & setbacks. Verification shall show that the lot was LEGALLY subdivided through the Town of Mesilla or that the lot has been in existence prior to February 1972.
2. Site Plan with dimensions and details.
3. Foundation plan with details.
4. Floor plan showing rooms, their uses and dimensions.
5. Cross section of walls
6. Roof and floor framing plan
8. Proof of legal access to the property.
9. Drainage plan.
10. Details of architectural style and color scheme (checklist included for Historical zones) - diagrams and elevations.
11. Proof of sewer service or a copy of septic tank permit; proof of water service (well permit or statement from the Public Utility providing water services).
12. Proof of legal access to the property.
13. Other information as necessary or required by the City Code or Community Development Department (See other side.)



The following are requirements to be included with all building permit applications for new structures or additions to existing structures, as well as other construction or fixtures that will be permanent in nature and affect the appearance or use of the property. (This includes fences, well houses, storage units, metal sheds, photo-voltaic panels that can be seen from the ground, etc.)

### BUILDING PERMIT REQUIREMENTS

A. Completed application, including:

1. Applicant's name
2. Applicant/property owners contact information
3. Physical address of property
4. Description of work to be done, including dimensions of any construction or repairs
5. Value of work to be done
6. Property owner's signature on the application

B. Include all information required in the checklist at the bottom of the application.

C. Additional information required:

---

---

---

---

# ONE LINE DIAGRAM & SITE MAP

SSL

Rooftop Photovoltaic Array

# Panels 10<sub>see</sub>

190 Azimuth  
Flush Mount

25° Tilt

Rapid Shutdown Compliant

**PV Array Information w/ Optimizers**  
 Number of Modules in Series String = 10  
 Maximum Current per String = 12 A  
 Max DC Voltage = 480 VDC  
 Max Vmp per String = 380 VDC

**10 AWG Conductors**  
**12 AWG Equipment**  
 Ground

Up to 6 Current Carrying  
 Conductors per Conduit  
 Voltage Drop < 1% if linear  
 distance is less than 125 Ft  
 3/4" Conduit or Greater

**PV Module Ratings @ STC**  
 Module Manufacturer = Trina  
 Module Model # = TSM-60  
 Max Power Current (Imp) = 9.92 A  
 Max Power Voltage (Vmp) = 40.3 V  
 Open Circuit Voltage (Voc) = 47.4 V  
 Short Circuit Current (Isc) = 10.45 A  
 Max Series Fuse (OCSPD) = 20 A  
 Maximum Power (Pmax) = 400 W  
 Max System Voltage = 1500V  
 Voc Temp Coefficient = -0.36 % / °C

### Estimated Annual DG System

Output 7240 kWh per year

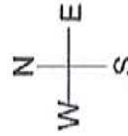

**Central Inverter Rating:**  
 Inverter Manufacturer = Solaredge Inverter  
 Model # = SE 3800H - US  
 Max DC Voltage Rating = 480V  
 Max Power = 5000W  
 Nominal AC Voltage = 120/240VAC  
 Number of Phases = 1  
 Max AC Current = 16 A

**PV Production Meter**  
 Meter Socket 250 V  
 100 Amp rated, Milbank  
 US934 w/ Isolated Neutral

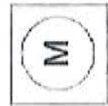

10 AWG  
L1, L2, N  
12 AWG EGC



3800 W  
Inverter

10 AWG  
L1, L2, N  
12 AWG EGC

**Panel Ratings:**  
 Bus Amp Rating = 100A  
 Service Voltage = 120/240 VAC  
 Main OCPD Rating = 100A  
 Inverter OCPD Rating = 20 Amp Backfed  
 Breaker



10 AWG  
L1, L2, N  
12 AWG EGC



Photovoltaic  
 Unfused Customer  
 Generation Disconnect  
 Rated 30 Amps  
 Within 10' of revenue  
 meter

To Utility

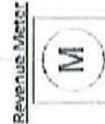

Revenue Meter

Outdoor Load Center  
 100 A Main  
 20 Amp Backfed Breaker  
 Attached placard  
 "Photovoltaic system connected"



- Notes & distances**
- Weather proof one line electric diagram of generating facility will be located at the point of service connection to the utility
  - PV array on roof of residence.
  - All AC equipment located by Utility Meter
  - Inverter located by meter
  - Photovoltaic AC Disconnect to main service panel within 5'
  - Main service panel to revenue meter within 5'
  - Photovoltaic AC Disconnect to revenue meter within 10'
  - Photovoltaic AC Disconnect is lockable and visible within sight to revenue meter

**Customer Name:** Francis D Williams  
 (575) 496-6185  
**Total System Size:** 3.8 kW AC / 4.05 kW DC @ STC  
 10 Solar Panels  
**Install Address:** 331 Capri Arc  
 Las Cruces NM 88005  
**Date:** Mar 10, 2022

**Installer Name:** Solar Smart Living, LLC  
 108 Ray Ward Place  
 Santa Teresa, NM 88008  
**Phone:** (915) 400-2995  
**Contact:** Javier Perea (915) 474-5824  
**Email:** jperea@SolarSmartLiving.com



**SITE MAP  
SSL**

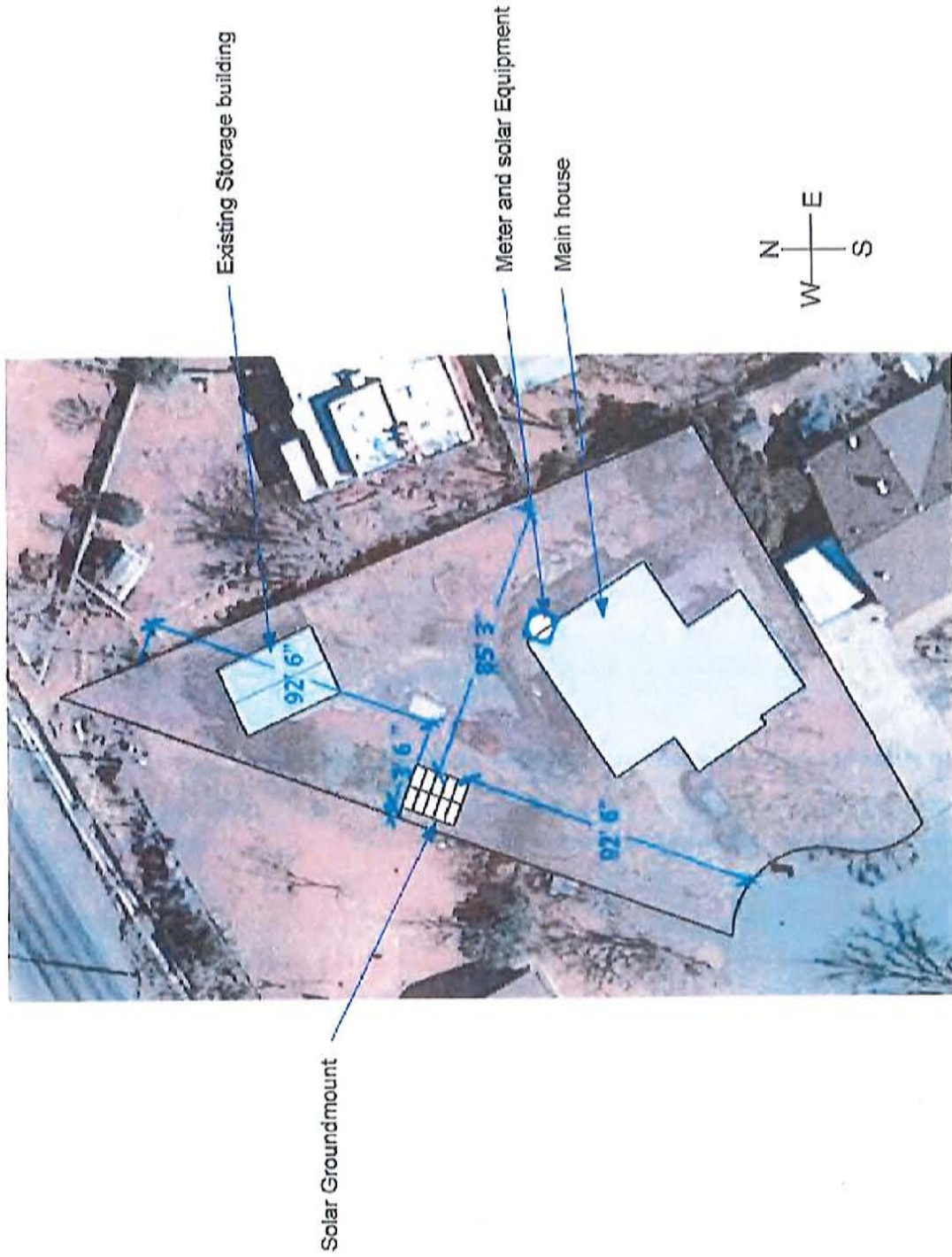

Customer Name: Francis D Williams  
 (575) 496-6185  
 Total System Size: 3.8 KW AC / 4.05 KW DC @ STC  
 10 Solar Panels  
 Install Address: 331 Capri Arc  
 Las Cruces NM 88005  
 Date: Mar 10, 2022

Installer Name: Solar Smart Living, LLC  
 108 Ray Ward Place  
 Santa Teresa, NM 88008  
 Phone: (915) 400-2995  
 Contact: Javier Perea (915) 474-5824  
 Email: jperea@SolarSmartLiving.com



## Single Phase Inverter with HD-Wave Technology

for North America

SE3000H-US / SE3800H-US / SE5000H-US / SE6000H-US /  
SE7600H-US / SE10000H-US / SE11400H-US

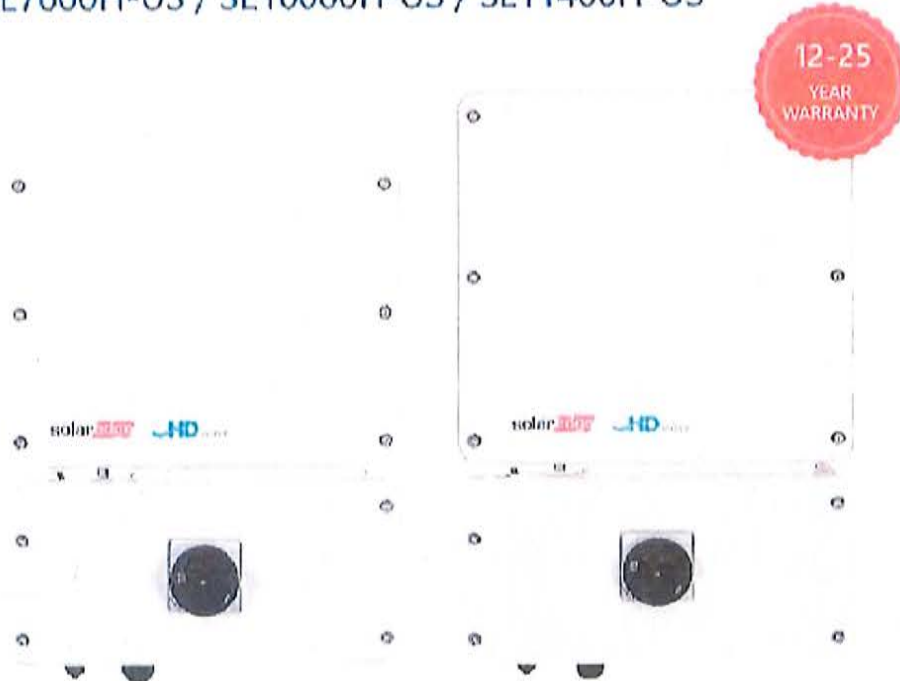

### Optimized installation with HD-Wave technology

- / Specifically designed to work with power optimizers
- / Record-breaking 99% weighted efficiency
- / Quick and easy inverter commissioning directly from a smartphone using the SolarEdge SetApp
- / Fixed voltage inverter for longer strings
- / Integrated arc fault protection and rapid shutdown for NEC 2014 and 2017, per article 690.11 and 690.12
- / UL1741 SA certified, for CPUC Rule 21 grid compliance
- / Small, lightweight, and easy to install both outdoors or indoors
- / Built-in module-level monitoring
- / Optional: Faster installations with built-in consumption metering (1% accuracy) and production revenue grade metering (0.5% accuracy, ANSI C12.20)

# / Single Phase Inverter with HD-Wave Technology for North America

SE3000H-US / SE3800H-US / SE5000H-US / SE6000H-US/  
SE7600H-US / SE10000H-US / SE11400H-US

MODEL NUMBER	SE3000H-US	SE3800H-US	SE5000H-US	SE6000H-US	SE7600H-US	SE10000H-US	SE11400H-US	
APPLICABLE TO INVERTERS WITH PART NUMBER	SEXXXXH-XXXXXBXX4							
<b>OUTPUT</b>								
Rated AC Power Output	3000	3800 @ 240V 3100 @ 208V	5000	6000 @ 240V 5000 @ 208V	7600	10000	11400 @ 240V 10000 @ 208V	VA
Maximum AC Power Output	5000	3800 @ 240V 3100 @ 208V	5000	5000 @ 240V 5000 @ 208V	7600	10000	11400 @ 240V 10000 @ 208V	VA
AC Output Voltage Min - Nom-4Wx (211 - 240 - 254)	✓	✓	✓	✓	✓	✓	✓	Vac
AC Output Voltage Min - Nom-4Aax (183 - 208 - 229)	-	✓	-	✓	-	-	✓	Vac
AC Frequency (Nominal)	59.3 - 60 - 60.5*							Hz
Maximum Continuous Output Current @240V	12.5	16	21	25	32	42	47.5	A
Maximum Continuous Output Current @208V	-	16	-	24	-	-	48.5	A
Power Factor	L Adjustable - 0.85 to 0.85							
GFD Threshold	1							A
Billy Monitoring, Mismatch Protection, Country Configurable Thresholds	Yes							
<b>INPUT</b>								
Maximum DC Power @240V	4650	5500	7750	9300	11000	15500	17050	W
Maximum DC Power @208V	-	5100	-	7750	-	-	15500	W
Transformer-less, Ungrounded	Yes							
Maximum Input Voltage	480							Vdc
Nominal DC Input Voltage	380			480				Vdc
Maximum Input Current @240V <sup>1</sup>	8.5	10.5	13.5	16.5	26	27	30.5	Adc
Maximum Input Current @208V <sup>2</sup>	-	9	-	11.5	-	-	27	Adc
Max. Input Short Circuit Current	-15							Ack
Reverse-Polarity Protection	Yes							
Ground-Fault Isolation Detection	6000 $\mu$ Sensitivity							
Maximum Inverter Efficiency	99				99.2			%
CEC Weighted Efficiency	99						99 @ 240V 98.5 @ 208V	%
Nighttime Power Consumption	< 2.5							W

\*For other regional settings, please contact Solid Edge's support.  
<sup>1</sup>A higher current share may be used; the inverter will limit its output current to the values stated.



# HiKu

## SUPER HIGH POWER POLY PERC MODULE

### 395 W ~ 420 W

CS3W-395 | 400 | 405 | 410 | 415 | 420P

#### MORE POWER



24 % higher power than conventional modules



Up to 4.5 % lower LCOE  
Up to 2.7 % lower system cost



Low NMOT:  $42 \pm 3$  °C  
Low temperature coefficient (Pmax):  
-0.37 % / °C



Better shading tolerance

#### MORE RELIABLE



Lower internal current,  
lower hot spot temperature



Minimizes micro-crack impacts



Heavy snow load up to 5400 Pa,  
wind load up to 3600 Pa\*



linear power output warranty\*



enhanced product warranty on materials and workmanship\*

\*According to the applicable Canadian Solar Limited Warranty Statement.

#### MANAGEMENT SYSTEM CERTIFICATES\*

ISO 9001:2015 / Quality management system  
ISO 14001:2015 / Standards for environmental management system  
OHSAS 18001:2007 / International standards for occupational health & safety

#### PRODUCT CERTIFICATES\*

IEC 61215 / IEC 61730: VDE / CE / MCS / KS / INMETRO  
UL 1703 / IEC 61215 performance; CEC listed (US)  
UL 1703; CSA / IEC 61701 ED2; VDE / IEC 62716; VDE / IEC 60068-2-68; SGS  
UNI 9177 Reaction to Fire: Class 1 / Take-a-way



\* As there are different certification requirements in different markets, please contact your local Canadian Solar sales representative for the specific certificates applicable to the products in the region in which the products are to be used.

CANADIAN SOLAR (USA), INC. is committed to providing high quality solar products, solar system solutions and services to customers around the world. No. 1 module supplier for quality and performance/price ratio in JHS Module Customer Insight Survey. As a leading PV project developer and manufacturer of solar modules with over 38 GW deployed around the world since 2001.

\* For detail information, please refer to Installation Manual.



Customer Name: Francis D Williams  
(575) 496-6185  
Total System Size: 3.8 kW AC / 4.05 kW DC @ STC  
10 Solar Panels  
Install Address: 331 Capri Arc  
Las Cruces NM 88005  
Date: Mar 10, 2022

Installer Name: Solar Smart Living, LLC  
Installer Address: 108 Ray Ward Place  
Santa Teresa, NM 88008  
Phone: (915) 400-2995  
Contact: Javier Perea (915) 474-5824  
Email: jperea@SolarSmartLiving.com

**Project Details**

<b>Name</b>	311 Capit Ave	<b>Date</b>	04/24/2022
<b>Location</b>	311 Capit Ave, Las Colinas, 981 88005	<b>ASCE code</b>	7,10
<b>Total modules</b>	10	<b>Wind speed</b>	120 mph
<b>Module</b>	Canadian Solar: CS3W-405 (400mm)	<b>Snow load</b>	0 psf
<b>Dimensions</b>	82.99" x 41.26" x 1.57" (2108.0mm x 1048.0mm x 40.0mm)	<b>Wind exposure</b>	0
<b>Total watts</b>	4,050 W	<b>Piers</b>	4
		<b>Concrete</b>	2.56 yd <sup>3</sup>

**Substructure & Foundation**

<b>Tile</b>	25"	<b>South facing grade</b>	0"
<b>Pipe/tubing diameter</b>	3"	<b>Soil class</b>	4
<b>Foundation type</b>	Concrete	<b>Hole diameter</b>	24"



**Sub array #1**

<b>Rows</b>	5	<b>Columns</b>	2	<b>Repeats</b>	1
<b>Area</b>	13' 10" (EW) x 17' 6" (NS)	<b>Rail type</b>	XR1000	<b>Diagonal bracing</b>	00
<b>E/W spacing</b>	12' 8"	<b>Rail cantilever</b>	3' 9"	<b>Pipe cantilever</b>	7"
<b>Piers/repeat</b>	4	<b>Total south piers</b>	2 (6")	<b>Total north piers</b>	2 (10' 3")
<b>Total cross pipes</b>	2 (13' 10")	<b>Total pipe length</b>	60' 2"	<b>Uplift</b>	-1,771 lbs
<b>Shear</b>	1,437 lbs	<b>Moment</b>	3,593 ft-lbs		

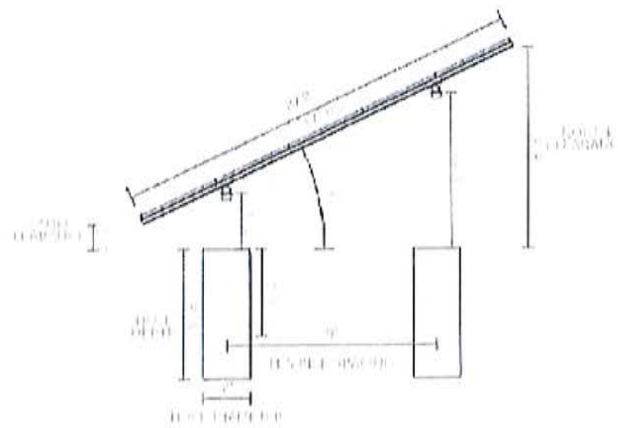
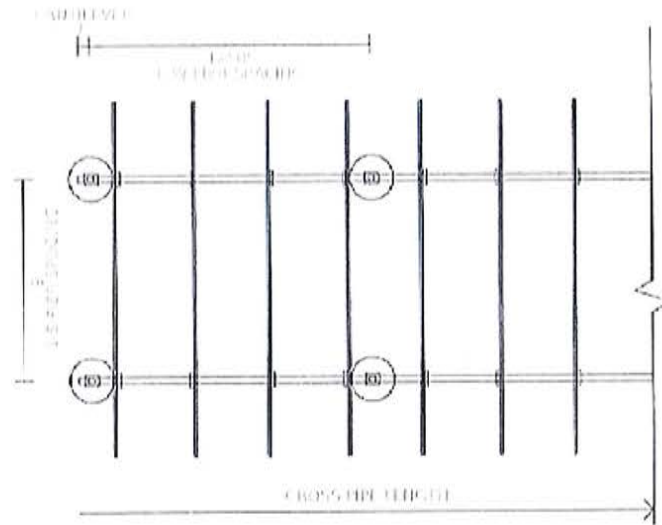

COMPONENT	IRONRIDGE UNIVERSAL FASTENING OBJECT
DESCRIPTION	IRONRIDGE UNIVERSAL FASTENING OBJECT
QUANTITY	1
DATE	08/10/01
DRAWN BY	W. B. BROWN
CHECKED BY	J. M. BROWN
APPROVED BY	J. M. BROWN

PROJECT NO.	
PROJECT NAME	
DATE	
SCALE	
BY	
CHECKED BY	
APPROVED BY	



PI SYSTEM DETAILS	5-UP 2" (UFO)
SCALE	1/2" = 1'-0"
DATE	08/10/01
BY	J. M. BROWN
CHECKED BY	J. M. BROWN
APPROVED BY	J. M. BROWN

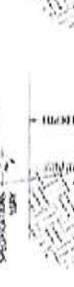
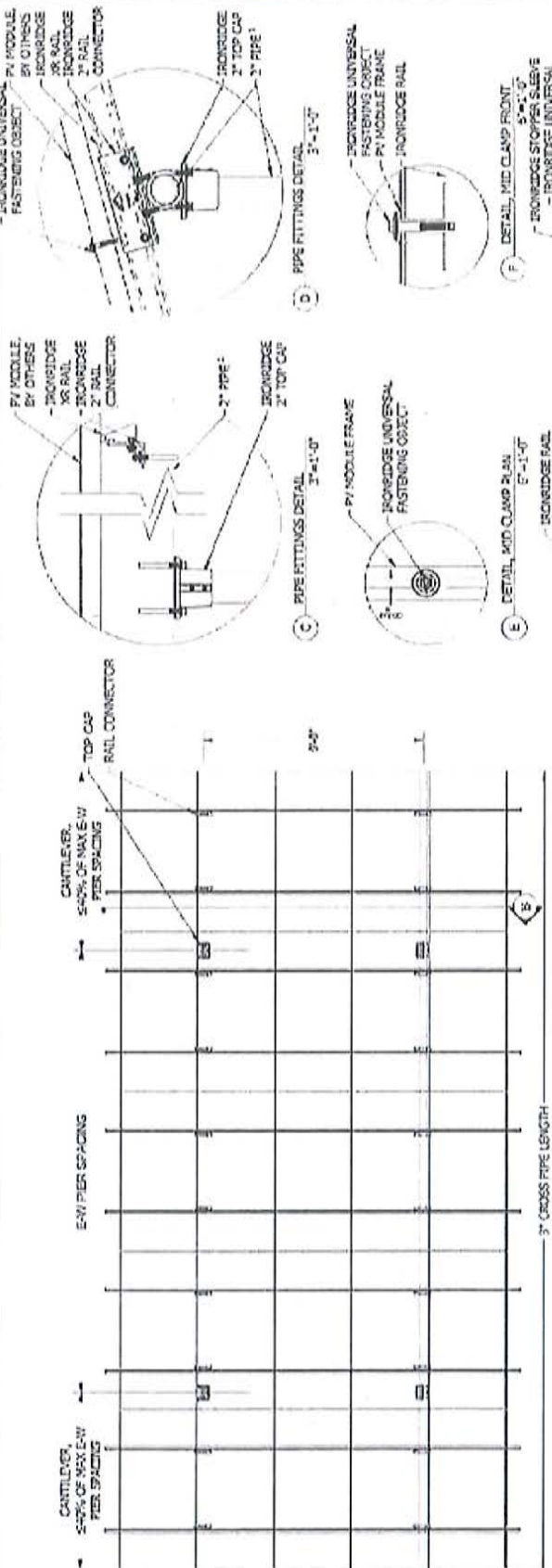

1. SCHEDULE 40 PIPE OR ALLIED MECHANICAL TUBING (8GA WALL THICKNESS)



## Starling Madison Lofquist, Inc.

*Consulting Structural and Forensic Engineers*

5224 South 39<sup>th</sup> Street, Phoenix, Arizona 85040  
tel: (602) 438-2500 fax: (602) 438-2505 ROC#291316 www.smleng.com

IronRidge  
28357 Industrial Boulevard  
Hayward, CA 94545

July 1, 2019  
Page 1 of 52

Attn: Mr. Corey Geiger, VP New Markets, IronRidge Inc.

Subject: Ground Mounting System – Structural Analysis – 5 Module (XR1000)

Dear Sir:

We have analyzed the subject ground mounted structure and determined that it is in compliance with the applicable sections of the following Reference Documents:

Codes: ASCE/SEI 7-10 Min. Design Loads for Buildings & Other Structures  
ASCE/SEI 7-16 Min. Design Loads for Buildings & Other Structures  
International Building Code, 2015 Edition  
International Building Code, 2018 Edition  
Other: AC428, Acceptance Criteria for Modular Framing Systems Used to Support PV  
Modules, dated Effective November 1, 2012 by ICC-ES  
Aluminum Design Manual, 2015 Edition  
IronRidge Exhibit EX-0002

The structure is a simple column (pier) and beam (cross pipe) system. The piers & cross pipes are ASTM A53 Grade B standard weight (schedule 40) steel pipes or Allied Mechanical Tubing. Please refer to Exhibit EX-0002 for approved pipe geometry and material properties. The tops of the piers are connected in the E-W direction by the cross pipes which cantilever over and extend past the end piers. The cross pipes are connected by proprietary IronRidge XR1000 Rails spanning up and down the slope which cantilever over and extend past the top and bottom cross pipes. There are typically two rails per column of modules. The modules are clamped to the rails by the IronRidge Module Mounting Clamps as shown in the attached Exhibit.

Gravity loads are transferred to the piers and foundations by the rails and cross pipes acting as simple beams. For lateral loads the system is either a cantilever structure or, when diagonal braces are provided, a braced frame. The effect of seismic loads (for all design categories A-F) have been determined to be less than the effect due to wind loads in all load conditions and combinations.

The pier spacing in the N-S direction is 9'-0". The pier spacing in the E-W direction is selected from load tables determined by the structural design for the specified slope, wind load, and snow load. The governing criteria for the pier spacing is either the spanning capacity of the cross pipes or the cantilever capacity of the pier. Simplified Load Tables 1A-F & 2A-F are included herein for reference.

More comprehensive information covering all load combinations is available at the IronRidge website, IronRidge.com.

Table 2A - MAXIMUM PIER SPACING (in)											
3" Unbraced Pipe Frame	Snow	Slope (deg)									
		psf	0	5	10	15	20	25	30	35	40
100 mph Exposure B	0	206	206	202	196	187	179	172	147	126	107
	10	182	182	180	178	176	175	172	147	126	107
	20	155	155	155	154	155	157	158	147	126	107
	30	145	146	145	144	146	149	152	147	126	107
	40	133	133	133	132	135	139	142	147	126	107
	50	121	121	122	123	126	130	135	142	126	107
105 mph Exposure B	0	206	206	194	189	179	172	157	133	114	97
	10	182	182	176	174	172	170	157	133	114	97
	20	155	155	162	161	152	153	154	133	114	97
	30	145	146	143	142	144	146	148	133	114	97
	40	133	133	131	131	133	136	140	133	114	97
	50	121	121	122	122	125	128	132	133	114	97
110 mph Exposure B	0	206	206	187	182	173	165	143	122	104	89
	10	182	182	172	170	167	165	143	122	104	89
	20	155	155	149	148	149	149	143	122	104	89
	30	145	146	141	140	141	143	143	122	104	89
	40	133	133	129	129	131	134	137	122	104	89
	50	121	121	120	120	123	126	130	122	104	89
120 mph Exposure B	0	198	203	174	169	160	153	120	102	87	74
	10	178	180	164	162	158	153	120	102	87	74
	20	153	154	144	143	143	143	120	102	87	74
	30	143	145	136	136	136	137	120	102	87	74
	40	131	132	126	125	127	129	120	102	87	74
	50	121	121	118	117	119	122	120	102	87	74
130 mph Exposure B	0	186	191	163	158	149	139	103	87	74	63
	10	171	174	157	154	149	139	103	87	74	63
	20	148	150	139	138	137	136	103	87	74	63
	30	140	141	132	131	131	131	103	87	74	63
	40	128	130	123	122	123	124	103	87	74	63
	50	119	120	115	114	116	118	103	87	74	63
140 mph Exposure B	0	175	180	153	148	140	120	89	75	64	55
	10	164	167	150	147	140	120	89	75	64	55
	20	144	146	134	133	131	120	89	75	64	55
	30	136	138	128	127	126	120	89	75	64	55
	40	125	127	119	118	119	119	89	75	64	55
	50	117	118	112	111	113	114	89	75	64	55
150 mph Exposure B	0	165	170	144	139	132	104	77	65	56	48
	10	158	161	143	139	132	104	77	65	56	48
	20	140	142	130	128	126	104	77	65	56	48
	30	132	134	124	122	121	104	77	65	56	48
	40	123	124	116	115	115	104	77	65	56	48
	50	117	118	112	111	113	114	89	75	64	55
160 mph Exposure B	0	157	161	136	131	124	92	68	57	49	42
	10	152	155	136	131	124	92	68	57	49	42
	20	136	138	125	123	121	92	68	57	49	42
	30	129	131	120	118	117	92	68	57	49	42
	40	120	121	113	111	111	92	68	57	49	42
	50	117	118	112	111	113	114	89	75	64	55

Notes: see page 14

Soil Class 4											
Table 4A - MINIMUM FOUNDATION DEPTHS (in)											
3" Pipe Frame Unbraced	Wind Speed & Exposure Category	Pier Dia (in)	Slope (deg)								
			0	5	10	15	20	25	30	35	40
100 mph Exposure B	12	42	42	48	60	66	78	90	90	90	90
	16	36	36	42	54	60	72	78	78	78	78
	20	36	36	36	48	54	66	72	72	72	72
	24	36	36	36	42	54	60	66	66	66	66
105 mph Exposure B	12	42	42	48	60	72	78	90	90	90	90
	16	36	36	42	54	60	72	78	78	78	78
	20	36	36	36	48	54	66	72	72	72	72
	24	36	36	36	48	54	60	66	66	66	66
110 mph Exposure B	12	42	42	48	60	72	84	90	90	90	90
	16	36	36	42	54	66	72	78	78	78	78
	20	36	36	42	48	60	66	72	72	72	72
	24	36	36	36	48	54	60	66	66	66	66
120 mph Exposure B	12	42	54	54	66	72	84	90	90	90	90
	16	36	42	48	54	66	78	78	78	78	78
	20	36	36	42	54	60	66	72	72	72	72
	24	36	36	36	48	54	66	66	66	66	66
130 mph Exposure B	12	48	54	60	66	78	90	90	90	90	90
	16	36	42	48	60	66	78	78	78	78	78
	20	36	36	42	54	60	72	72	72	72	72
	24	36	36	42	48	60	66	66	66	66	66
140 mph Exposure B	12	54	60	60	72	78	90	90	90	90	90
	16	42	48	48	60	72	78	78	78	78	78
	20	36	36	42	54	66	72	72	72	72	72
	24	36	36	42	54	60	66	66	66	66	66
150 mph Exposure B	12	54	66	66	78	84	90	90	90	90	90
	16	42	48	54	60	72	78	78	78	78	78
	20	36	42	48	60	66	72	72	72	72	72
	24	36	36	42	54	60	66	66	66	66	*
160 mph Exposure B	12	60	72	72	84	84	90	90	90	90	90
	16	48	54	54	66	78	78	78	78	78	78
	20	36	42	48	60	72	72	72	72	72	72
	24	36	36	42	54	66	66	66	66	66	*

Notes: see page 52

Notes for Tables 3 & 4:

1. Concrete Weight = 145 pcf /  $f_c = 2500$  psi
2. Provide Air Entraining Admixture for freeze and thaw cycles as required for colder climates.
3. Skin Friction per 2018 IBC & 2015 IBC 1810.3.3.1.4 & 5
4. Top 1'-0" of soil neglected for Skin Friction
5. Snow Load = 0 psf – tabulated values are conservative for Snow Loads > 0 psf
6. \* indicates special foundation required. Contact IronRidge
7. Resistance to corrosion and/or sulfate attack, along with possible adverse effects due to expansive soils has not been considered in these foundation recommendations. SML Engineers assumes no liability with regard to these items.
8. Soil classification is to be determined and verified by the end user of this certification letter.

The analysis assumes that the array, including the connections and associated hardware, are installed in a workmanlike manner in accordance with the IronRidge Ground Mount Installation Manual and generally accepted standards of construction practice. Verification of PV Module capacity to support the loads associated with the given array shall be the responsibility of the Contractor or Owner and not IronRidge or Starling Madison Lofquist.

Please feel free to contact me at your convenience if you have any questions.

Respectfully yours,

Tres Warner, P.E.  
Design Division Manager

Tres J  
Warner

Digitally signed by Tres  
J Warner  
DN: c=US, o=Starling  
Madison Lofquist Inc,  
ou=A01410C00000174  
6F7B4222000053B6,  
cn=Tres J Warner  
Date: 2020.12.30  
13:42:36 -07'00'





**RESOLUTION 2022-03**

**ACCEPTANCE AND APPROVAL OF THE FY 2021 AUDIT**

**WHEREAS**, the Town of Mesilla is required by statute to contract with an independent auditor to perform the required annual audit or agreed upon procedures for Fiscal Year 2021; and,

**WHEREAS**, the Town of Mesilla has directed the accomplishment of the audit for FY 2021 be completed; and,

**WHEREAS**, this audit has been completed and presented to the Town of Mesilla per the March 8, 2022 Letter from the Statue Auditor authorizing release of the FY 2021 audit.

**WHEREAS**, NMAC 2.2.2.10 (M) (4) provides in pertinent part that “Once the audit report is officially released to the agency by the state auditor (by a release letter) and the required waiting period of five calendar days has passed, unless waived by the agency in writing, the audit report shall be presented by the IPA, to a quorum of the governing authority of the agency at a meeting held in accordance with the Open Meetings Act, if applicable;” and,

**NOW THEREFORE, BE IT RESOLVED**, that the Town of Mesilla does hereby accept and approve the completed audit report as indicated within this document.

**ACCEPTED AND APPROVED** this 11th day of April 2022 in regular session by the Board of Trustees, at Town of Mesilla, Dona Ana County, New Mexico.

\_\_\_\_\_  
Nora L. Barraza  
Mayor

ATTEST:

\_\_\_\_\_  
Rani Bush  
Town Clerk/Treasurer

<b>ROLL CALL VOTE</b>	<b>Y/N</b>
Mayor Barraza	_____
Mayor Pro Tem Johnson-Burick	_____
Trustee Cadena	_____
Trustee Garcia	_____
Trustee Merrick	_____

BRIAN S. COLÓN, ESQ. CFE  
STATE AUDITOR



NATALIE CORDOVA, CPA  
DEPUTY STATE AUDITOR

## State of New Mexico Office of the State Auditor

CONSTITUENT SERVICES  
(505) 476-3821

Via: Email

3/8/2022

OSA Ref No. 6124

Cynthia Stoechner-Hernandez, Town Clerk/Treasurer  
cynthias-h@mesillanm.gov  
Town of Mesilla

Re: Authorization to Release 2021 Town of Mesilla Audit Report

The Office of the State Auditor (OSA) received the audit report for your agency on 2/14/2022. The OSA has completed the review of the audit report required by Section 12-6-14(B) NMSA 1978 and any applicable provisions of the Audit Rule. This letter is your authorization to make the final payment to the Independent Public Accountant (IPA) who contracted with your agency to perform the financial and compliance audit. In accordance with the audit contract, the IPA is required to deliver to the agency the number of copies of the report specified in the contract.

Pursuant to Section 12-6-5 NMSA 1978, the audit report does not become a public record until five days after the date of this release letter, unless your agency has already submitted a written waiver to the OSA. Once the five-day period has expired, or upon the OSA's receipt of a written waiver:

- the OSA will send the report to the Department of Finance and Administration, the Legislative Finance Committee and other relevant oversight agencies;
- the OSA will post the report on its public website; and
- the agency and the IPA shall arrange for the IPA to present the report to the governing authority of the agency, per the Audit Rule, at a meeting held in accordance with the Open Meetings Act, if applicable.

The IPA's findings and comments are included in the audit report on page 95-98. It is ultimately the responsibility of the governing authority of the agency to take corrective action on all findings and comments.

Sincerely,

A handwritten signature in blue ink, appearing to read "B. Colón".

Brian S. Colón, Esq. CFE  
State Auditor

cc. Beasley, Mitchell & Co., LLP



## **BOARD ACTION FORM**

**ITEM:**

Resolution for LP10004 LGTPF - Second Amendment to the Local Government Transportation Project Fund for extension of time.

**BACKGROUND:**

Public Works requested a one year extension of time for the construction phase of the Calle del Norte Phase II multi-use path. This extension of time is needed due to the time lost due to EBID denial of a permit. A change of route and termini was approved by the BOT on March 8, 2021 and approved by NMDOT on August 8, 2021.

**SUPPORTING INFORMATION:**

LGTPF Grant Agreement dated November 7, 2019

**BOT OPTIONS:**

1. Approve the application.
2. Modify the application with conditions.
3. Reject the application.



RESOLUTION NO. 2022-04

**A RESOLUTION AUTHORIZING THE SECOND AMENDMENT TO THE LOCAL GOVERNMENT ROAD FUND PROGRAM BY NEW MEXICO DEPARTMENT OF TRANSPORTATION**

**WHEREAS**, the Town of Mesilla and the New Mexico Department of Transportation have entered into a grant agreement under the Local Government Transportation Fund Program for a local road project.

**WHEREAS**, the total cost of the project will be \$844,000 to be funded in proportional share by the parties hereto as follows:

- a. New Mexico Department of Transportation's share shall be 95% or \$801,800  
and
- b. Town of Mesilla's proportional matching share shall be 5% or \$42,200

TOTAL PROJECT COST IS \$844,000

The Town of Mesilla shall pay all costs, which exceed the total amount of \$844,000.

**NOW THEREFORE**, be it resolved in open session that **Town of Mesilla** determines, resolves, and orders as follows:

That the project for this Cooperative agreement is adopted and has a priority standing.

The amended agreement terminates on June 30, 2023, and the **Town of Mesilla** incorporates all the agreements, covenants, and understandings between the parties hereto concerning the subject matter hereof, and all such covenants, agreements and understandings have been merged into the written agreement.

**NOW THEREFORE**, be it resolved by the Town of Mesilla to continue with Cooperative Agreement for Project Control Number LP10004 with the New Mexico Department of Transportation for LGTPF Program for Year 2019 for **Calle del Norte Multi-Use Path Phase II – Design, right-of-way acquisition, full construction, drainage improvements, construction management and miscellaneous improvements** within the control of the **Town of Mesilla** in New Mexico.

**PASSED, APPROVED and ADOPTED by the Board of Trustees at its meeting of April 11, 2022.**

\_\_\_\_\_  
Nora L. Barraza  
Mayor

ATTEST:

\_\_\_\_\_  
Rani Bush  
Town Clerk/Treasurer

Contract No.	<u>D18400/2</u>
Vendor No.	<u>0000054357</u>
Control No.	<u>LP10004</u>

**SECOND AMENDMENT TO  
LOCAL GOVERNMENT TRANSPORTATION PROJECT FUND**

This **First Amendment** is to the Agreement entered into between the New Mexico Department of Transportation (Department) and the Town of Mesilla (Public Entity). This Amendment is effective as of the date of the last party to sign on the signature page.

**RECITALS**

**Whereas**, the Department and the Public Entity entered into an Agreement, Contract No. D18400, on 11/7/2019 and,

**Whereas**, Section 19 allows for modification of the Agreement by an instrument in writing executed by the parties; and,

**Whereas**, the Department and the Public Entity want to extend the term of the Agreement to allow for Project completion; and,

**Whereas**, the parties agree to modify this Agreement.

**Now, therefore**, the Department and the Public Entity agree as follows:

1. Section 6 Term, is deleted and replaced by the following:

**6. Term**

This Agreement becomes effective upon signature of all parties. The effective date is the date when the last party signed the Agreement on the signature page below. This Agreement terminates on the earliest of the following dates: (a) Department receipt of the Certification of Completion or (b) **June 30, 2023**. In the event an extension to the term is needed, the Public Entity shall provide written notice along with detailed justification to the Department sixty (60) days prior to the expiration date to ensure timely processing of an Amendment. Neither party shall have any obligation after said date except as stated in Sections 2e, 4l, 4n and 7.

All other obligations set forth in the Original Agreement shall remain in full force and effect unless expressly amended or modified by this First Amendment.

**In Witness Whereof**, each party is signing this Agreement on the date stated opposite that party's signature.

**New Mexico Department of Transportation**

By: \_\_\_\_\_  
Cabinet Secretary or Designee

Date: \_\_\_\_\_

Approved as to form and legal sufficiency by the New Mexico Department of Transportation's Office of General Counsel

By: \_\_\_\_\_  
Assistant General Counsel

Date: \_\_\_\_\_

Town of Mesilla

By: \_\_\_\_\_

Date: \_\_\_\_\_

Name: \_\_\_\_\_

Title: \_\_\_\_\_

ATTEST:

By: \_\_\_\_\_  
Town of Mesilla Clerk

Date: \_\_\_\_\_

## Community Development Monthly report for March 2022

- Late February and early March Business registration letter went out with some ordinance information on business, signs and parking in the Town of Mesilla, the due date for business licenses was March 15<sup>th</sup>. The parking fees were addressed with some of the plaza businesses, explanations on parking fees and why they are needed and where the funding goes, still working on getting some of the business to come into compliance with parking fees as renewals are still coming in.
- We had fourteen (14) building applications submitted the month of march, nine (9) went before the Architectural Styles Committee and four (4) moved on the PZHAC. The five that didn't pass were due to proposed plan was not clear or insufficient information on building plan. PZHAC reviewed ten (10) cases, one case was not passed due to needing more information on the building plan.
- Ongoing, working with CODES, Marshals and the Fire Marshals on ordinances and seeking compliance on violations. Answering emails, phone calls and walk-ins, educating the public, contactors, realtors, and anyone seeking to build or do business in Mesilla on the Town Code.

Joe P.

4/06/2022

## Community Projects Report

Project	Description
Current Contact information	Dorothy Sellers Email: <a href="mailto:DorothyS@mesillanm.gov">DorothyS@mesillanm.gov</a> Work: 575-524-3262 Cell:575-571-3890
Cinco de Mayo	Fiesta preparations in full swing. Have 2 vendor booths left and need to fill 1.5 hours of entertainment.
Visitors Guide	Working with TuMedia on the creation and distribution of the 2022 Mesilla Visitors Guide.  Visitors guide is at the printers and should be distributed soon
Social Media and website	Keep social media up to date with things happening in Mesilla. Will continue to push visitors to the website. Mesilla website is now visible on Google search.
Mercado	Workshop visits are planned for January to ensure vendors are meeting the requirements to sell at Mercado. Reviewing new applications for the upcoming Fiscal Year
Clean & Beautiful Grant	New application for FY23 is in progress and will announce new info soon.  Town of Mesilla has been awarded \$6,686.56 for FY22. The award includes two community clean-up events. New trash cans for the Town Hall

	Parking Lot. Promotional items to be given at fiestas and youth interns to man booths at the fiestas.
NM Tourism Grant	The media push of our video and banner is set to resume. Working with NM CoOp to update branding on video and banner. Application for FY23 submitted/

TOWN OF MESILLA  
 REVENUE & EXPENSE REPORT (UNAUDITED)  
 AS OF: MARCH 31ST, 2022

10 -GENERAL FUND

REVENUE

FUND	ACCOUNT #	ACCOUNT NAME	CURRENT BUDGET	CURRENT PERIOD	PRIOR YEAR PO ADJUST.	Y-T-D ACTUAL	Y-T-D ENCUMBRANCE	BUDGET BALANCE	% OF BUDGET
TAXES - LOCAL									
	10-41002	FRANCHISE TAX	70,000.00	6,675.43	0.00	57,087.37	0.00	12,912.63	81.55
	10-41030	INFRASTRUCTURE	49,281.00	137.27	0.00	629.92	0.00	48,651.08	1.28
	10-41050	MUN.GROSS REC. TAX 48%	489,400.00	70,223.58	0.00	655,422.92	0.00	166,022.92	133.92
	10-41060	PROPERTY TAX	105,000.00	885.58	0.00	68,289.65	0.00	36,710.35	65.04
		TOTAL TAXES - LOCAL	713,681.00	77,921.86	0.00	781,429.86	0.00	67,748.86	109.49
TAXES - STATE									
	10-42020	CIGARETTE TAX .02	0.00	0.00	0.00	0.00	0.00	0.00	0.00
	10-42050	STATE GROSS REC.1.225-48%	517,215.00	53,779.24	0.00	499,207.25	0.00	18,007.75	96.52
	10-42060	EQUIVALENT COMPENSATING TAX	11,220.00	0.00	0.00	2,094.23	0.00	9,125.77	18.67
	10-42070	INTERSTATE TELECOM	7,140.00	0.00	0.00	90.43	0.00	7,049.57	1.27
	10-42080	AUTO LIC DIST/REG/ALL CITIES	15,300.00	1,031.44	0.00	9,893.73	0.00	5,406.27	64.66
	10-42090	INTERNET SALES TAXES	27,000.00	0.00	0.00	8,062.76	0.00	18,937.24	29.86
		TOTAL TAXES - STATE	577,875.00	54,810.68	0.00	519,348.40	0.00	58,526.60	89.87
LICENSES & PERMITS									
	10-43010	BUILDING PERMITS	30,000.00	24,028.60	0.00	54,070.20	0.00	24,070.20	180.23
	10-43020	BUSINESS LICENSES	20,000.00	6,580.00	0.00	10,900.00	0.00	9,100.00	54.50
	10-43030	LIQUOR LICENSES	5,000.00	0.00	0.00	1,000.00	0.00	4,000.00	20.00
	10-43060	OTHER PERMITS	37,000.00	100.00	0.00	37,774.00	0.00	774.00	102.09
	10-43100	ANIMAL CONTROL LICENSES	6,000.00	0.00	0.00	3.00	0.00	5,997.00	0.05
		TOTAL LICENSES & PERMITS	98,000.00	30,708.60	0.00	103,747.20	0.00	5,747.20	105.86
CHARGES FOR SERVICES									
	10-44010	OTHER ADMINISTRATIVE FEES	25,000.00	6,155.50	0.00	7,668.80	0.00	17,331.20	30.68
	10-44070	COMM CENTER/PLAZA RENTALS	52,000.00	3,960.58	0.00	25,570.22	0.00	26,429.78	49.17
		TOTAL CHARGES FOR SERVICES	77,000.00	10,116.08	0.00	33,239.02	0.00	43,760.98	43.17
FINES & FORFEITS									
	10-45020	COURT FINES	70,000.00	5,155.00	0.00	49,452.63	0.00	20,547.37	70.65
		TOTAL FINES & FORFEITS	70,000.00	5,155.00	0.00	49,452.63	0.00	20,547.37	70.65
MISCELLANEOUS REVENUES									
	10-46030	INTEREST	2,000.00	0.00	0.00	339.48	0.00	1,660.52	16.97
	10-46040	DWI SEIZURE	0.00	0.00	0.00	0.00	0.00	0.00	0.00
	10-46050	RESTITUTION	1,000.00	0.00	0.00	0.00	0.00	1,000.00	0.00
	10-46060	REFUNDS/REIMBURSEMENTS	7,000.00	73.10	0.00	73.10	0.00	7,073.10	1.04
	10-46090	MISCELLANEOUS INCOME	23,000.00	7,012.97	0.00	11,938.16	0.00	11,061.84	51.91
	10-46095	VISITOR CENTER REVENUES	1,000.00	0.00	0.00	118.88	0.00	881.12	11.89
		TOTAL MISCELLANEOUS REVENUES	34,000.00	6,939.87	0.00	12,323.42	0.00	21,676.58	36.25





TOWN OF MESILLA  
 REVENUE & EXPENSE REPORT (UNAUDITED)  
 AS OF: MARCH 31ST, 2022

10 -GENERAL FUND  
 FINANCE  
 DEPARTMENTAL EXPENDITURES

FUND	ACCOUNT #	ACCOUNT NAME	CURRENT BUDGET	CURRENT PERIOD	PRIOR YEAR PO ADJUST.	Y-T-D ACTUAL	Y-T-D ENCUMBRANCE	BUDGET BALANCE	% OF BUDGET
PERSONNEL EXPENSES									
	10-501-1001	SALARIES	113,300.00	5,912.64	0.00	78,875.45	0.00	34,424.55	69.62
	10-501-1003	FICA/MEDICARE	8,667.00	427.85	0.00	5,529.77	0.00	3,137.23	63.80
	10-501-1004	PERA/ICMA	6,995.00	203.54	0.00	3,860.66	0.00	3,134.34	55.19
	10-501-1005	HEALTH & LIFE INSURANCE	19,485.00	1,162.02	0.00	20,849.05	0.00	1,364.05	107.00
	10-501-1006	WORKERS' COMPENSATION	2,000.00	4.60	0.00	139.43	0.00	1,860.57	6.97
	10-501-1007	UNEMPLOYMENT INSURANCE	648.00	0.00	0.00	0.00	0.00	648.00	0.00
		TOTAL PERSONNEL EXPENSES	151,095.00	7,710.65	0.00	109,254.36	0.00	41,840.64	72.31
OPERATING EXPENSES									
	10-501-2110	TRAVEL/CONF/PER DIEM	3,000.00	0.00	0.00	1,101.88	0.00	1,898.12	36.73
	10-501-2240	VEHICLE R & M	500.00	0.00	0.00	0.00	0.00	500.00	0.00
	10-501-2241	EQUIPMENT R & M	2,737.00	0.00	0.00	304.86	0.00	2,432.14	11.14
	10-501-2242	MEDICAL/DRUG ADMIN	3,650.00	54.16	0.00	192.12	0.00	3,457.88	5.26
	10-501-2305	AUDIT FEES	15,134.00	0.00	0.00	14,962.56	0.00	171.44	98.87
	10-501-2315	PROFESSIONAL SERVICES	1,500.00	0.00	0.00	0.00	0.00	1,500.00	0.00
	10-501-2320	AGREEMENTS/CONTRACTS	115,924.00	13,171.66	0.00	116,209.42	0.00	285.42	100.25
	10-501-2405	OFFICE SUPPLIES	5,000.00	0.00	0.00	1,700.97	0.00	3,299.03	34.02
	10-501-2520	EMPLOYEE TRAINING	1,000.00	487.25	0.00	537.25	0.00	462.75	53.73
	10-501-2530	INSURANCE	16,100.00	0.00	0.00	13,818.46	0.00	2,281.54	85.83
	10-501-2535	POSTAGE	2,720.00	375.31	0.00	2,622.25	0.00	97.75	96.41
	10-501-2540	PRINT/PUBLISH/ADVERTISE	4,700.00	826.34	0.00	6,535.07	0.00	1,835.07	139.04
	10-501-2570	DUES & SUBSCRIPTIONS	5,502.00	674.73	0.00	7,182.93	0.00	1,680.93	130.55
	10-501-2575	TELEPHONE	6,750.00	909.95	0.00	8,090.98	0.00	1,340.98	119.87
	10-501-2580	UTILITIES	33,971.00	3,178.85	0.00	27,803.56	0.00	6,167.44	81.84
	10-501-2585	FUEL	2,000.00	0.00	0.00	179.20	0.00	1,820.80	8.96
	10-501-2590	ELECTIONS	0.00	0.00	0.00	0.00	0.00	0.00	0.00
	10-501-2597	OTHER EXPENSES	3,500.00	0.00	0.00	1,692.43	0.00	1,807.57	48.36
	10-501-2599	DEPRECIATION EXPENSE	0.00	0.00	0.00	0.00	0.00	0.00	0.00
		TOTAL OPERATING EXPENSES	223,688.00	19,678.25	0.00	202,933.94	0.00	20,754.06	90.72
CAPITAL OUTLAY									
	10-501-3000	STATE INVESTMENT FUND LOS	0.00	0.00	0.00	0.00	0.00	0.00	0.00
	10-501-3050	CAPITAL OUTLAY	0.00	0.00	0.00	0.00	0.00	0.00	0.00
		TOTAL CAPITAL OUTLAY	0.00	0.00	0.00	0.00	0.00	0.00	0.00
TOTAL FINANCE			374,783.00	27,388.90	0.00	312,188.30	0.00	62,594.70	83.30

TOWN OF MESILLA  
 REVENUE & EXPENSE REPORT (UNAUDITED)  
 AS OF: MARCH 31ST, 2022

10 -GENERAL FUND  
 COURT  
 DEPARTMENTAL EXPENDITURES

FUND	ACCOUNT #	ACCOUNT NAME	CURRENT BUDGET	CURRENT PERIOD	PRIOR YEAR PO ADJUST.	Y-T-D ACTUAL	Y-T-D ENCUMBRANCE	BUDGET BALANCE	% OF BUDGET
PERSONNEL EXPENSES									
	10-502-1001	SALARIES	42,540.00	3,657.92	0.00	37,659.70	0.00	4,880.30	88.53
	10-502-1003	FICA/MEDICARE	3,254.00	279.84	0.00	2,806.32	0.00	447.68	86.24
	10-502-1004	PERA/ICMA	2,947.00	358.47	0.00	3,588.64	0.00 (	641.64)	121.77
	10-502-1005	HEALTH & LIFE INSURANCE	60.00	9.94	0.00	89.46	0.00 (	29.46)	149.10
	10-502-1006	WORKERS' COMPENSATION	400.00	4.60	0.00	139.43	0.00	260.57	34.86
	10-502-1007	UNEMPLOYMENT INSURANCE	997.00	0.00	0.00	0.00	0.00	997.00	0.00
	10-502-1008	OVERTIME	0.00	0.00	0.00	0.00	0.00	0.00	0.00
		TOTAL PERSONNEL EXPENSES	50,198.00	4,310.77	0.00	44,283.55	0.00	5,914.45	88.22
OPERATING EXPENSES									
	10-502-2110	TRAVEL/CONF/TRAINING	200.00	0.00	0.00	0.00	0.00	200.00	0.00
	10-502-2241	EQUIPMENT R & M	0.00	0.00	0.00	0.00	0.00	0.00	0.00
	10-502-2320	AGREEMENTS/CONTRACTS	5,200.00	226.09	0.00	2,155.89	0.00	3,044.11	41.46
	10-502-2405	OFFICE SUPPLIES	3,000.00	48.00	0.00	2,632.10	0.00	367.90	87.74
	10-502-2535	POSTAGE	2,500.00	0.00	0.00	166.00	0.00	2,334.00	6.64
	10-502-2570	DUES & SUBSCRIPTIONS	1,000.00	0.00	0.00	285.00	0.00	715.00	28.50
	10-502-2575	TELEPHONE	5,000.00	226.33	0.00	2,174.68	0.00	2,825.32	43.49
	10-502-2596	INDIGENT FEES	4,800.00	541.56	0.00	5,572.99	0.00 (	772.99)	116.10
	10-502-2597	OTHER EXPENSES	1,315.00	420.00	0.00	2,238.25	0.00 (	923.25)	170.21
		TOTAL OPERATING EXPENSES	23,015.00	1,461.98	0.00	15,224.91	0.00	7,790.09	66.15
CAPITAL OUTLAY									
	10-502-3050	CAPITAL OUTLAY	0.00	0.00	0.00	0.00	0.00	0.00	0.00
		TOTAL CAPITAL OUTLAY	0.00	0.00	0.00	0.00	0.00	0.00	0.00
TOTAL COURT			73,213.00	5,772.75	0.00	59,508.46	0.00	13,704.54	81.28

TOWN OF MESILLA  
 REVENUE & EXPENSE REPORT (UNAUDITED)  
 AS OF: MARCH 31ST, 2022

10 -GENERAL FUND  
 MARSHAL  
 DEPARTMENTAL EXPENDITURES

FUND	ACCOUNT #	ACCOUNT NAME	CURRENT BUDGET	CURRENT PERIOD	PRIOR YEAR PO ADJUST.	Y-T-D ACTUAL	Y-T-D ENCUMBRANCE	BUDGET BALANCE	% OF BUDGET
PERSONNEL EXPENSES									
	10-503-1001	SALARIES	302,497.00	19,504.02	0.00	171,868.51	0.00	130,628.49	56.82
	10-503-1003	FICA/MEDICARE	23,908.00	1,592.51	0.00	15,087.86	0.00	8,820.14	63.11
	10-503-1004	PERA/ICMA	44,927.00	3,217.98	0.00	30,507.12	0.00	14,419.88	67.90
	10-503-1005	HEALTH & LIFE INSURANCE	20,168.00	1,949.30	0.00	16,611.66	0.00	3,556.34	82.37
	10-503-1006	WORKERS' COMPENSATION	10,844.00	13.80	0.00	2,123.98	0.00	8,720.02	19.59
	10-503-1007	UNEMPLOYMENT INSURANCE	7,236.00	0.00	0.00	0.00	0.00	7,236.00	0.00
	10-503-1008	OVERTIME ALLOTMENT	25,000.00	3,775.75	0.00	36,255.05	0.00	11,255.05	145.02
		TOTAL PERSONNEL EXPENSES	434,580.00	30,053.36	0.00	272,454.18	0.00	162,125.82	62.69
OPERATING EXPENSES									
	10-503-2110	TRAVEL/CONF/TRAINING	5,000.00	0.00	0.00	3,201.77	920.00	878.23	82.44
	10-503-2240	VEHICLE R & M	24,500.00	4,448.63	0.00	16,458.43	0.00	8,041.57	67.18
	10-503-2241	EQUIPMENT R & M	5,000.00	22,003.00	0.00	9,658.30	0.00	4,658.30	193.17
	10-503-2320	AGREEMENTS/CONTRACTS	15,939.00	3,741.95	0.00	9,632.39	0.00	6,306.61	60.43
	10-503-2324	ANIMAL CONTROL	6,000.00	0.00	0.00	2,778.03	0.00	3,221.97	46.30
	10-503-2405	OFFICE SUPPLIES	1,000.00	10.99	0.00	460.14	0.00	539.86	46.01
	10-503-2420	UNIFORM ALLOWANCE	15,000.00	4,994.97	0.00	8,977.02	830.00	5,192.98	65.38
	10-503-2450	COMM/DISPATCH	0.00	0.00	0.00	0.00	0.00	0.00	0.00
	10-503-2505	PETCO GRANT	0.00	0.00	0.00	0.00	0.00	0.00	0.00
	10-503-2530	INSURANCE	36,500.00	0.00	0.00	19,302.30	0.00	17,197.70	52.88
	10-503-2535	POSTAGE	100.00	0.00	0.00	61.64	0.00	38.36	61.64
	10-503-2540	PRINT/PUBLISH/ADVERTISE	750.00	0.00	0.00	594.32	0.00	155.68	79.24
	10-503-2570	DUES & SUBSCRIPTIONS	150.00	0.00	0.00	75.00	0.00	75.00	50.00
	10-503-2575	TELEPHONE/GPS	2,500.00	208.11	0.00	3,169.06	0.00	669.06	126.76
	10-503-2585	FUEL	16,000.00	1,743.27	0.00	15,321.51	0.00	678.49	95.76
	10-503-2597	DWI SEIZURES TOWING	0.00	649.87	0.00	649.87	0.00	649.87	0.00
		TOTAL OPERATING EXPENSES	128,439.00	37,800.79	0.00	90,339.78	1,750.00	36,349.22	71.70
CAPITAL OUTLAY									
	10-503-3050	AMMO FOR QUALS	2,085.00	0.00	0.00	1,765.00	0.00	320.00	84.65
		TOTAL CAPITAL OUTLAY	2,085.00	0.00	0.00	1,765.00	0.00	320.00	84.65
<hr/>									
		TOTAL MARSHAL	565,104.00	67,854.15	0.00	364,558.96	1,750.00	198,795.04	64.82

TOWN OF MESILLA  
 REVENUE & EXPENSE REPORT (UNAUDITED)  
 AS OF: MARCH 31ST, 2022

10 -GENERAL FUND  
 FIRE

DEPARTMENTAL EXPENDITURES

FUND	ACCOUNT #	ACCOUNT NAME	CURRENT BUDGET	CURRENT PERIOD	PRIOR YEAR PO ADJUST.	Y-T-D ACTUAL	Y-T-D ENCUMBRANCE	BUDGET BALANCE	% OF BUDGET
PERSONNEL EXPENSES									
	10-504-1001	SALARIES	60,986.00	4,784.96	0.00	47,380.80	0.00	13,605.20	77.69
	10-504-1003	FICA/MEDICARE	4,665.00	356.22	0.00	3,536.13	0.00	1,128.87	75.80
	10-504-1004	PERA/ICMA	13,356.00	1,047.90	0.00	10,376.40	0.00	2,979.60	77.69
	10-504-1005	HEALTH & LIFE INSURANCE	30,809.00	1,162.02	0.00	27,433.18	0.00	3,375.82	89.04
	10-504-1006	WORKERS' COMPENSATION	3,729.00	2.30	0.00	870.49	0.00	2,858.51	23.34
	10-504-1007	UNEMPLOYMENT INSURANCE	1,098.00	0.00	0.00	0.00	0.00	1,098.00	0.00
		TOTAL PERSONNEL EXPENSES	114,643.00	7,353.40	0.00	89,597.00	0.00	25,046.00	78.15
OPERATING EXPENSES									
	10-504-2315	MEDICAL DIRECTOR	5,993.00	250.00	0.00	2,216.62	0.00	3,776.38	36.99
	10-504-2320	AGREEMENTS/CONTRACTS	3,000.00	0.00	0.00	0.00	0.00	3,000.00	0.00
	10-504-2420	EQUIPMENT	913.00	3,555.98	0.00	4,656.59	0.00	3,743.59	510.03
	10-504-2444	FIRE TRUCK LOAN	0.00	0.00	0.00	0.00	0.00	0.00	0.00
	10-504-2597	OTHER EXPENSES	0.00	0.00	0.00	0.00	0.00	0.00	0.00
		TOTAL OPERATING EXPENSES	9,906.00	3,805.98	0.00	6,873.21	0.00	3,032.79	69.38
CAPITAL OUTLAY									
	10-504-3050	CAPITAL OUTLAY	0.00	0.00	0.00	0.00	0.00	0.00	0.00
		TOTAL CAPITAL OUTLAY	0.00	0.00	0.00	0.00	0.00	0.00	0.00
TOTAL FIRE			124,549.00	11,159.38	0.00	96,470.21	0.00	28,078.79	77.46

TOWN OF MESILLA  
 REVENUE & EXPENSE REPORT (UNAUDITED)  
 AS OF: MARCH 31ST, 2022

10 -GENERAL FUND  
 MAINTENANCE  
 DEPARTMENTAL EXPENDITURES

FUND	ACCOUNT #	ACCOUNT NAME	CURRENT BUDGET	CURRENT PERIOD	PRIOR YEAR PO ADJUST.	Y-T-D ACTUAL	Y-T-D ENCUMBRANCE	BUDGET BALANCE	% OF BUDGET
PERSONNEL EXPENSES									
	10-505-1001	SALARIES	67,724.00	4,238.57	0.00	41,361.92	0.00	26,362.08	61.07
	10-505-1003	FICA/MEDICARE	5,181.00	308.50	0.00	3,124.80	0.00	2,056.20	60.31
	10-505-1004	PERA/ICMA	6,277.00	415.38	0.00	4,053.48	0.00	2,223.52	64.58
	10-505-1005	HEALTH & LIFE INSURANCE	78.00	4.42	0.00	39.78	0.00	38.22	51.00
	10-505-1006	WORKERS' COMPENSATION	2,737.00	2.30	0.00	132.53	0.00	2,604.47	4.84
	10-505-1007	UNEMPLOYMENT INSURANCE	996.00	0.00	0.00	0.00	0.00	996.00	0.00
	10-505-1008	OVERTIME ALLOTMENT	2,000.00	0.00	0.00	0.00	0.00	2,000.00	0.00
		TOTAL PERSONNEL EXPENSES	84,993.00	4,969.17	0.00	48,712.51	0.00	36,280.49	57.31
OPERATING EXPENSES									
	10-505-2110	TRAVEL/CONF/PER DIEM	0.00	0.00	0.00	0.00	0.00	0.00	0.00
	10-505-2205	BUILDING MAINTENANCE	6,800.00	140.21	0.00	4,697.31	0.00	2,102.69	69.08
	10-505-2230	MAINT/GROUNDS/ROADS	20,449.16	3,286.40	0.00	21,661.62	0.00	1,212.46	105.93
	10-505-2231	DOH ZIKA FUNDING	0.00	0.00	0.00	0.00	0.00	0.00	0.00
	10-505-2232	STREET SIGNS	0.00	0.00	0.00	249.80	0.00	249.80	0.00
	10-505-2300	INSURANCE CLAIMS	1,000.00	0.00	0.00	0.00	0.00	1,000.00	0.00
	10-505-2303	AGREEMENTS/CONTRACTS	4,070.00	0.00	0.00	933.42	0.00	3,136.58	22.93
	10-505-2321	VECTOR CONTROL	17,700.00	253.12	0.00	13,446.48	0.00	4,253.52	75.97
	10-505-2545	EBID TAXES	1,117.00	0.00	0.00	0.00	0.00	1,117.00	0.00
	10-505-2597	OTHER EXPENSES	3,041.95	0.00	0.00	2,093.94	0.00	948.01	68.84
		TOTAL OPERATING EXPENSES	54,178.11	3,679.73	0.00	43,082.57	0.00	11,095.54	79.52
CAPITAL OUTLAY									
	10-505-3050	CAPITAL OUTLAY	0.00	0.00	0.00	0.00	0.00	0.00	0.00
		TOTAL CAPITAL OUTLAY	0.00	0.00	0.00	0.00	0.00	0.00	0.00
TOTAL MAINTENANCE			139,171.11	8,648.90	0.00	91,795.08	0.00	47,376.03	65.96

TOWN OF MESILLA  
REVENUE & EXPENSE REPORT (UNAUDITED)  
AS OF: MARCH 31ST, 2022

10 -GENERAL FUND  
EXECUTIVE/LEGISLATIVE  
DEPARTMENTAL EXPENDITURES

FUND	ACCOUNT #	ACCOUNT NAME	CURRENT BUDGET	CURRENT PERIOD	PRIOR YEAR PO ADJUST.	Y-T-D ACTUAL	Y-T-D ENCUMBRANCE	BUDGET BALANCE	% OF BUDGET
PERSONNEL EXPENSES									
	10-506-1001	SALARIES	62,000.00	4,769.12	0.00	47,691.20	0.00	14,308.80	76.92
	10-506-1003	FICA/MEDICARE	4,743.00	364.86	0.00	3,648.60	0.00	1,094.40	76.93
	10-506-1004	PERA/ICMA	2,352.00	120.60	0.00	1,628.10	0.00	723.90	69.22
	10-506-1006	WORKER'S COMPENSATION	497.00	11.50	0.00	132.75	0.00	364.25	26.71
	10-506-1007	UNEMPLOYMENT INSURANCE	440.00	0.00	0.00	0.00	0.00	440.00	0.00
		TOTAL PERSONNEL EXPENSES	70,032.00	5,266.08	0.00	53,100.65	0.00	16,931.35	75.82
OPERATING EXPENSES									
	10-506-2110	TRAVEL/CONF/TRAINING	8,000.00	0.00	0.00	1,657.01	0.00	6,342.99	20.71
	10-506-2310	LEGAL FEES - GM	37,065.00	0.00	0.00	26,783.18	0.00	10,281.82	72.26
	10-506-2311	LEGAL FEES - COURT	33,550.00	0.00	0.00	32,383.19	0.00	1,166.81	96.52
	10-506-2315	PROFESSIONAL SERVICES	3,104.00	0.00	0.00	0.00	0.00	3,104.00	0.00
	10-506-2405	OFFICE SUPPLIES	500.00	203.98	0.00	332.67	0.00	167.33	66.53
	10-506-2530	INSURANCE	2,500.00	0.00	0.00	1,250.00	0.00	1,250.00	50.00
	10-506-2540	PRINT/PUBLISH/ADVERTISE	15,000.00	0.00	0.00	0.00	0.00	15,000.00	0.00
	10-506-2570	DUES & SUBSCRIPTIONS	4,000.00	0.00	0.00	3,587.71	0.00	412.29	89.69
	10-506-2575	TELEPHONE	1,270.00	126.11	0.00	971.59	0.00	298.41	76.50
	10-506-2597	OTHER EXPENSES	8,666.00	0.00	0.00	1,942.80	0.00	6,723.20	22.42
		TOTAL OPERATING EXPENSES	113,655.00	330.09	0.00	68,908.15	0.00	44,746.85	60.63
CAPITAL OUTLAY									
	10-506-3050	CAPITAL OUTLAY	0.00	0.00	0.00	0.00	0.00	0.00	0.00
		TOTAL CAPITAL OUTLAY	0.00	0.00	0.00	0.00	0.00	0.00	0.00
TOTAL EXECUTIVE/LEGISLATIVE			183,687.00	5,596.17	0.00	122,008.80	0.00	61,678.20	66.42

TOWN OF MESILLA  
 REVENUE & EXPENSE REPORT (UNAUDITED)  
 AS OF: MARCH 31ST, 2022

10 -GENERAL FUND  
 COMMUNITY PROGRAMS  
 DEPARTMENTAL EXPENDITURES

FUND	ACCOUNT #	ACCOUNT NAME	CURRENT BUDGET	CURRENT PERIOD	PRIOR YEAR PO ADJUST.	Y-T-D ACTUAL	Y-T-D ENCUMBRANCE	BUDGET BALANCE	% OF BUDGET
PERSONNEL EXPENSES									
	10-507-1001	SALARIES	38,512.00	2,746.24	0.00	31,016.80	0.00	7,495.20	80.54
	10-507-1003	FICA/MEDICARE	2,678.00	181.36	0.00	2,106.32	0.00	571.68	78.65
	10-507-1004	PERA/ICMA	3,815.00	269.14	0.00	2,664.90	0.00	1,150.10	69.85
	10-507-1005	HEALTH & LIFE INSURANCE	17,737.00	1,364.40	0.00	12,280.22	0.00	5,456.78	69.24
	10-507-1006	WORKER'S COMPENSATION	240.00	2.30	0.00	197.66	0.00	42.34	82.36
	10-507-1007	UNEMPLOYMENT INSURANCE	997.00	0.00	0.00	0.00	0.00	997.00	0.00
		TOTAL PERSONNEL EXPENSES	63,979.00	4,563.44	0.00	48,265.90	0.00	15,713.10	75.44
OPERATING EXPENSES									
	10-507-2110	TRAVEL/CONF/TRAINING	1,000.00	0.00	0.00	0.00	0.00	1,000.00	0.00
	10-507-2405	OFFICE SUPPLIES	750.00	44.97	0.00	270.96	0.00	479.04	36.13
	10-507-2411	COMMUNITY PROGRAMS	8,769.00	0.00	0.00	5,447.74	0.00	3,321.26	62.12
	10-507-2535	POSTAGE	890.00	180.90	0.00	180.90	0.00	709.10	20.33
	10-507-2540	PRINT/PUBLISH/ADVERTISE	15,764.00	0.00	0.00	5,651.52	0.00	10,112.48	35.85
	10-507-2570	DUES & SUBSCRIPTIONS	2,500.00	111.95	0.00	867.92	0.00	1,632.08	34.72
	10-507-2575	TELEPHONE	1,604.00	0.00	0.00	0.00	0.00	1,604.00	0.00
	10-507-2597	CLEAN & BEAUTIFUL GRANT	14,400.00	0.00	0.00	336.00	0.00	14,064.00	2.33
		TOTAL OPERATING EXPENSES	45,677.00	337.82	0.00	12,755.04	0.00	32,921.96	27.92
CAPITAL OUTLAY									
	10-507-3050	CAPITAL OUTLAY	0.00	0.00	0.00	0.00	0.00	0.00	0.00
		TOTAL CAPITAL OUTLAY	0.00	0.00	0.00	0.00	0.00	0.00	0.00
TOTAL COMMUNITY PROGRAMS			109,656.00	4,901.26	0.00	61,020.94	0.00	48,635.06	55.65



TOWN OF MESILLA  
 REVENUE & EXPENSE REPORT (UNAUDITED)  
 AS OF: MARCH 31ST, 2022

10 -GENERAL FUND  
 COMM CNTR/PLAZA  
 DEPARTMENTAL EXPENDITURES

FUND	ACCOUNT #	ACCOUNT NAME	CURRENT BUDGET	CURRENT PERIOD	PRIOR YEAR PO ADJUST.	Y-T-D ACTUAL	Y-T-D ENCUMBRANCE	BUDGET BALANCE	% OF BUDGET
OPERATING EXPENSES									
	10-508-2205	BUILDING MAINTENANCE	26,642.00	523.85	0.00	26,935.71	0.00 (	293.71)	101.10
	10-508-2210	BUILDING R&M	9,000.00	10,158.60	0.00	10,158.60	0.00 (	1,158.60)	112.87
	10-508-2252	ELECTRICAL R & M	5,500.00	0.00	0.00	1,083.32	0.00	4,416.68	19.70
	10-508-2410	R & M SUPPLIES	1,300.00	0.00	0.00	531.36	0.00	768.64	40.87
	10-508-2516	COMM/PLAZA REFUNDS	200.00	300.00	0.00	1,300.00	0.00 (	1,100.00)	650.00
	10-508-2580	UTILITIES	20,000.00	2,509.50	0.00	6,754.96	0.00	13,245.04	33.77
	10-508-2597	OTHER EXPENSES	0.00	0.00	0.00	0.00	0.00	0.00	0.00
		TOTAL OPERATING EXPENSES	62,642.00	13,491.95	0.00	46,763.95	0.00	15,878.05	74.65
CAPITAL OUTLAY									
	10-508-3050	CAPITAL OUTLAY	0.00	0.00	0.00	0.00	0.00	0.00	0.00
		TOTAL CAPITAL OUTLAY	0.00	0.00	0.00	0.00	0.00	0.00	0.00
		TOTAL COMM CNTR/PLAZA	62,642.00	13,491.95	0.00	46,763.95	0.00	15,878.05	74.65

TOWN OF MESILLA  
 REVENUE & EXPENSE REPORT (UNAUDITED)  
 AS OF: MARCH 31ST, 2022

10 -GENERAL FUND  
 COMMUNITY DEVELOPMENT  
 DEPARTMENTAL EXPENDITURES

FUND	ACCOUNT #	ACCOUNT NAME	CURRENT BUDGET	CURRENT PERIOD	PRIOR YEAR PO ADJUST.	Y-T-D ACTUAL	Y-T-D ENCUMBRANCE	BUDGET BALANCE	% OF BUDGET
PERSONNEL EXPENSES									
	10-509-1001	SALARIES	20,000.00	3,040.00	0.00	8,420.52	0.00	11,579.48	42.10
	10-509-1003	FICA/MEDICARE	2,678.00	232.56	0.00	644.18	0.00	2,033.82	24.05
	10-509-1004	PERA/ICMA	3,430.00	297.92	0.00	825.20	0.00	2,604.80	24.06
	10-509-1005	HEALTH & LIFE INSURANCE	13,000.00	0.00	0.00	7.87	0.00	12,992.13	0.06
	10-509-1006	WORKER'S COMPENSATION	496.00	2.30	0.00	2.30	0.00	493.70	0.46
	10-509-1007	UNEMPLOYMENT INSURANCE	998.00	0.00	0.00	0.00	0.00	998.00	0.00
		TOTAL PERSONNEL EXPENSES	40,602.00	3,572.78	0.00	9,900.07	0.00	30,701.93	24.38
OPERATING EXPENSES									
	10-509-2110	TRAVEL/CONF/TRAINING	0.00	0.00	0.00	0.00	0.00	0.00	0.00
	10-509-2405	OFFICE SUPPLIES	0.00	0.00	0.00	0.00	0.00	0.00	0.00
	10-509-2520	EMPLOYEE TRAINING	0.00	0.00	0.00	0.00	0.00	0.00	0.00
	10-509-2535	POSTAGE	0.00	0.00	0.00	0.00	0.00	0.00	0.00
	10-509-2540	PRINT/PUBLISH/ADVERTISE	0.00	0.00	0.00	0.00	0.00	0.00	0.00
	10-509-2570	DUES & SUBSCRIPTIONS	0.00	0.00	0.00	0.00	0.00	0.00	0.00
	10-509-2585	FUEL	0.00	0.00	0.00	0.00	0.00	0.00	0.00
	10-509-2597	OTHER EXPENSES	0.00	0.00	0.00	0.00	0.00	0.00	0.00
	10-509-2598	BLDG INSP CONTRACT	0.00	0.00	0.00	0.00	0.00	0.00	0.00
		TOTAL OPERATING EXPENSES	0.00	0.00	0.00	0.00	0.00	0.00	0.00
CAPITAL OUTLAY									
	10-509-3050	CAPITAL OUTLAY	0.00	0.00	0.00	0.00	0.00	0.00	0.00
		TOTAL CAPITAL OUTLAY	0.00	0.00	0.00	0.00	0.00	0.00	0.00
TOTAL COMMUNITY DEVELOPMENT			40,602.00	3,572.78	0.00	9,900.07	0.00	30,701.93	24.38
TOTAL EXPENDITURES			1,673,407.11	148,386.24	0.00	1,164,214.77	1,750.00	507,442.34	69.68
EXCESS REVENUES/EXPENDITURES			1,548.89	37,265.85	0.00	476,484.85	( 1,750.00)	( 473,185.96)	650.00
TRANSFERS IN									
	10-48888	TRANSFER IN	50,000.00	0.00	0.00	0.00	0.00	50,000.00	0.00
	10-48889	TRANSFER IN/INVESTMENTS	0.00	0.00	0.00	0.00	0.00	0.00	0.00
		TOTAL TRANSFERS IN	50,000.00	0.00	0.00	0.00	0.00	50,000.00	0.00



TOWN OF MESILLA  
 REVENUE & EXPENSE REPORT (UNAUDITED)  
 AS OF: MARCH 31ST, 2022

12 -FIRE PROTECTION FUND

REVENUE

FUND	ACCOUNT #	ACCOUNT NAME	CURRENT BUDGET	CURRENT PERIOD	PRIOR YEAR PO ADJUST.	Y-T-D ACTUAL	Y-T-D ENCUMBRANCE	BUDGET BALANCE	% OF BUDGET
MISCELLANEOUS REVENUES									
	12-46030	PROCEEDS FROM DEBT	0.00	0.00	0.00	0.00	0.00	0.00	0.00
	12-46090	MISC INCOME/DONATIONS	2,000.00	2,490.00	0.00	13,640.00	0.00	( 11,640.00)	682.00
		TOTAL MISCELLANEOUS REVENUES	2,000.00	2,490.00	0.00	13,640.00	0.00	( 11,640.00)	682.00
INTER-GOV/GRANTS									
	12-47040	STATE ALLOTMENT	244,897.00	0.00	0.00	225,225.00	0.00	19,672.00	91.97
		TOTAL INTER-GOV/GRANTS	244,897.00	0.00	0.00	225,225.00	0.00	19,672.00	91.97
		TOTAL REVENUES	246,897.00	2,490.00	0.00	238,865.00	0.00	8,032.00	96.75

TOWN OF MESILLA  
 REVENUE & EXPENSE REPORT (UNAUDITED)  
 AS OF: MARCH 31ST, 2022

12 -FIRE PROTECTION FUND  
 FIRE DEPARTMENT  
 DEPARTMENTAL EXPENDITURES

FUND	ACCOUNT #	ACCOUNT NAME	CURRENT BUDGET	CURRENT PERIOD	PRIOR YEAR PO ADJUST.	Y-T-D ACTUAL	Y-T-D ENCUMBRANCE	BUDGET BALANCE	% OF BUDGET
PERSONNEL EXPENSES									
	12-504-1001	STIPEND FROM DONATIONS	0.00	0.00	0.00	3,357.00	0.00 (	3,357.00)	0.00
	12-504-1003	FICA/MEDICARE	0.00	0.00	0.00	256.83	0.00 (	256.83)	0.00
	TOTAL PERSONNEL EXPENSES		0.00	0.00	0.00	3,613.83	0.00 (	3,613.83)	0.00
OPERATING EXPENSES									
	12-504-2110	TRAVEL/CONF/TRAINING	3,564.00	0.00	0.00	7,172.45	0.00 (	3,608.45)	201.25
	12-504-2205	BUILDING R & M	35,000.00	0.00	0.00	1,126.50	0.00	33,873.50	3.22
	12-504-2240	VEHICLE R & M	36,043.43	1,541.60	0.00	35,449.32	0.00	594.11	98.35
	12-504-2241	EQUIPMENT R & M	20,000.00	3,138.98	0.00	18,979.79	0.00	1,020.21	94.90
	12-504-2320	AGREEMENTS/CONTRACTS	5,000.00	0.00	0.00	1,656.76	0.00	3,343.24	33.14
	12-504-2405	OFFICE SUPPLIES	17,211.00	0.00	0.00	0.00	0.00	17,211.00	0.00
	12-504-2407	MAINTENANCE SUPPLIES	5,000.00	4,347.80	0.00	9,466.95	0.00 (	4,466.95)	189.34
	12-504-2410	EQUIPMENT PURCHASES	3,200.00	18.71	0.00	19,099.36	0.00 (	15,899.36)	596.86
	12-504-2412	DEMO SUPPLIES	3,000.00	0.00	0.00	826.22	0.00	2,173.78	27.54
	12-504-2420	UNIFORM ALLOWANCE	5,000.00	0.00	0.00	5,131.68	0.00 (	131.68)	102.63
	12-504-2530	INSURANCE	6,000.00	0.00	0.00	5,943.11	0.00	56.89	99.05
	12-504-2540	PRINT/PUBLISH/ADVERTISE	200.00	0.00	0.00	0.00	0.00	200.00	0.00
	12-504-2570	DUES/SUBSCRIPTIONS	1,000.00	324.57	0.00	2,010.44	0.00 (	1,010.44)	201.04
	12-504-2575	TELEPHONE/PAGERS	10,000.00	909.28	0.00	7,357.77	0.00	2,642.23	73.58
	12-504-2580	UTILITIES	20,000.00	1,237.65	0.00	11,859.74	0.00	8,140.26	59.30
	12-504-2585	FUEL	20,000.00	781.95	0.00	5,697.57	0.00	14,302.43	28.49
	12-504-2598	MISCELLANEOUS	4,971.00	0.00	0.00	52.85	0.00	4,918.15	1.06
	TOTAL OPERATING EXPENSES		195,189.43	12,300.54	0.00	131,830.51	0.00	63,358.92	67.54
CAPITAL OUTLAY									
	12-504-3050	CAPITAL OUTLAY	54,279.00	0.00	0.00	18,586.25 (	9,074.25)	44,767.00	17.52
	TOTAL CAPITAL OUTLAY		54,279.00	0.00	0.00	18,586.25 (	9,074.25)	44,767.00	17.52
TOTAL FIRE DEPARTMENT									
			249,468.43	12,300.54	0.00	154,030.59 (	9,074.25)	104,512.09	58.11
TOTAL EXPENDITURES									
			249,468.43	12,300.54	0.00	154,030.59 (	9,074.25)	104,512.09	58.11
EXCESS REVENUES/EXPENDITURES									
			( 2,571.43) (	9,810.54)	0.00	84,834.41	9,074.25 (	96,480.09)	652.00-

TOWN OF MESILLA  
 REVENUE & EXPENSE REPORT (UNAUDITED)  
 AS OF: MARCH 31ST, 2022

13 -RECREATION FUND

REVENUE

FUND	ACCOUNT #	ACCOUNT NAME	CURRENT BUDGET	CURRENT PERIOD	PRIOR YEAR PO ADJUST.	Y-T-D ACTUAL	Y-T-D ENCUMBRANCE	BUDGET BALANCE	% OF BUDGET
TAXES - STATE									
	13-42010	RECREATION TAXES 1%	0.00	0.00	0.00	0.00	0.00	0.00	0.00
		TOTAL TAXES - STATE	0.00	0.00	0.00	0.00	0.00	0.00	0.00
MISCELLANEOUS REVENUES									
	13-46090	MISC INCOME/DONATIONS	500.00	0.00	0.00	100.00	0.00	400.00	20.00
		TOTAL MISCELLANEOUS REVENUES	500.00	0.00	0.00	100.00	0.00	400.00	20.00
INTER-GOV/GRANTS									
	13-47080	SUMMER REC GRANTS	4,500.00	0.00	0.00	0.00	0.00	4,500.00	0.00
		TOTAL INTER-GOV/GRANTS	4,500.00	0.00	0.00	0.00	0.00	4,500.00	0.00
		TOTAL REVENUES	5,000.00	0.00	0.00	100.00	0.00	4,900.00	2.00

TOWN OF MESILLA  
 REVENUE & EXPENSE REPORT (UNAUDITED)  
 AS OF: MARCH 31ST, 2022

13 -RECREATION FUND  
 RECREATION  
 DEPARTMENTAL EXPENDITURES

FUND	ACCOUNT #	ACCOUNT NAME	CURRENT BUDGET	CURRENT PERIOD	PRIOR YEAR PO ADJUST.	Y-T-D ACTUAL	Y-T-D ENCUMBRANCE	BUDGET BALANCE	% OF BUDGET
PERSONNEL EXPENSES									
	13-513-1001	SALARIES	0.00	0.00	0.00	0.00	0.00	0.00	0.00
	13-513-1003	FICA/MEDICARE	0.00	0.00	0.00	0.00	0.00	0.00	0.00
	13-513-1006	WORKER'S COMPENSATION	21.00	0.00	0.00	0.00	0.00	21.00	0.00
		TOTAL PERSONNEL EXPENSES	21.00	0.00	0.00	0.00	0.00	21.00	0.00
OPERATING EXPENSES									
	13-513-2598	SUPPLIES	4,979.00	0.00	0.00	1,017.57	0.00	3,961.43	20.44
		TOTAL OPERATING EXPENSES	4,979.00	0.00	0.00	1,017.57	0.00	3,961.43	20.44
		TOTAL RECREATION	5,000.00	0.00	0.00	1,017.57	0.00	3,982.43	20.35
		TOTAL EXPENDITURES	5,000.00	0.00	0.00	1,017.57	0.00	3,982.43	20.35
		EXCESS REVENUES/EXPENDITURES	0.00	0.00	0.00	( 917.57)	0.00	917.57	0.00
TRANSFERS IN									
	13-48888	TRANSFER IN	4,000.00	0.00	0.00	0.00	0.00	4,000.00	0.00
		TOTAL TRANSFERS IN	4,000.00	0.00	0.00	0.00	0.00	4,000.00	0.00
TRANSFERS OUT									
	13-513-4444	TRANSFERS OUT	4,000.00	0.00	0.00	0.00	0.00	4,000.00	0.00
		TOTAL TRANSFERS OUT	4,000.00	0.00	0.00	0.00	0.00	4,000.00	0.00
		NET TRANSFERS	0.00	0.00	0.00	0.00	0.00	0.00	0.00
		REVENUES & TRANSFERS IN OVER/ (UNDER) EXPENDITURES & TRANSFERS OUT	0.00	0.00	0.00	( 917.57)	0.00	917.57	0.00

TOWN OF MESILLA  
 REVENUE & EXPENSE REPORT (UNAUDITED)  
 AS OF: MARCH 31ST, 2022

14 -EMS FUND

REVENUE

FUND	ACCOUNT #	ACCOUNT NAME	CURRENT BUDGET	CURRENT PERIOD	PRIOR YEAR PO ADJUST.	Y-T-D ACTUAL	Y-T-D ENCUMBRANCE	BUDGET BALANCE	% OF BUDGET
MISCELLANEOUS REVENUES									
	14-46090	MISCELLANEOUS INCOME	18,855.00	0.00	0.00	18,855.00	0.00	0.00	100.00
		TOTAL MISCELLANEOUS REVENUES	18,855.00	0.00	0.00	18,855.00	0.00	0.00	100.00
INTER-GOV/GRANTS									
	14-47035	STATE ALLOTMENT	7,142.00	0.00	0.00	7,142.00	0.00	0.00	100.00
		TOTAL INTER-GOV/GRANTS	7,142.00	0.00	0.00	7,142.00	0.00	0.00	100.00
		TOTAL REVENUES	25,997.00	0.00	0.00	25,997.00	0.00	0.00	100.00



TOWN OF MESILLA  
 REVENUE & EXPENSE REPORT (UNAUDITED)  
 AS OF: MARCH 31ST, 2022

14 -EMS FUND  
 EMS

DEPARTMENTAL EXPENDITURES

FUND	ACCOUNT #	ACCOUNT NAME	CURRENT BUDGET	CURRENT PERIOD	PRIOR YEAR PO ADJUST.	Y-T-D ACTUAL	Y-T-D ENCUMBRANCE	BUDGET BALANCE	% OF BUDGET
OPERATING EXPENSES									
	14-514-2110	TRAVEL/CONF/TRAINING	2,500.00	0.00	0.00	0.00	0.00	2,500.00	0.00
	14-514-2241	EQUIPMENT R & M	1,400.00	0.00	0.00	170.49	0.00	1,229.51	12.18
	14-514-2320	AGREEMENTS/CONTRACTS	1,142.00	0.00	0.00	1,706.75	0.00 (	564.75)	149.45
	14-514-2410	EQUIPMENT/SUPPLIES	2,100.00	0.00	0.00	5,372.56	0.00 (	3,272.56)	255.84
	14-514-2545	LOCAL SYSTEM IMP GRANT	18,855.00	0.00	0.00	1,647.60	0.00	17,207.40	8.74
		TOTAL OPERATING EXPENSES	25,997.00	0.00	0.00	8,897.40	0.00	17,099.60	34.22
CAPITAL OUTLAY									
	14-514-3050	CAPITAL OUTLAY	0.00	0.00	0.00	0.00	0.00	0.00	0.00
		TOTAL CAPITAL OUTLAY	0.00	0.00	0.00	0.00	0.00	0.00	0.00
TOTAL EMS									
			25,997.00	0.00	0.00	8,897.40	0.00	17,099.60	34.22
TOTAL EXPENDITURES									
			25,997.00	0.00	0.00	8,897.40	0.00	17,099.60	34.22
EXCESS REVENUES/EXPENDITURES									
			0.00	0.00	0.00	17,099.60	0.00 (	17,099.60)	0.00
TRANSFERS IN									
	14-48888	TRANSFER IN	0.00	0.00	0.00	0.00	0.00	0.00	0.00
		TOTAL TRANSFERS IN	0.00	0.00	0.00	0.00	0.00	0.00	0.00
TRANSFERS OUT									
	14-514-4444	TRANSFER OUT	0.00	0.00	0.00	0.00	0.00	0.00	0.00
		TOTAL TRANSFERS OUT	0.00	0.00	0.00	0.00	0.00	0.00	0.00
NET TRANSFERS									
			0.00	0.00	0.00	0.00	0.00	0.00	0.00
REVENUES & TRANSFERS IN OVER/ (UNDER) EXPENDITURES & TRANSFERS OUT									
			0.00	0.00	0.00	17,099.60	0.00 (	17,099.60)	0.00

TOWN OF MESILLA  
 REVENUE & EXPENSE REPORT (UNAUDITED)  
 AS OF: MARCH 31ST, 2022

15 -AMERICAN RECOVERY FUND

REVENUE

FUND	ACCOUNT #	ACCOUNT NAME	CURRENT BUDGET	CURRENT PERIOD	PRIOR YEAR PO ADJUST.	Y-T-D ACTUAL	Y-T-D ENCUMBRANCE	BUDGET BALANCE	% OF BUDGET
CHARGES FOR SERVICES									
	15-44083	ARFA DEPOSITS	453,921.00	0.00	0.00	226,960.50	0.00	226,960.50	50.00
		TOTAL CHARGES FOR SERVICES	453,921.00	0.00	0.00	226,960.50	0.00	226,960.50	50.00
MISCELLANEOUS REVENUES									
	15-46030	INTEREST	0.00	0.00	0.00	0.00	0.00	0.00	0.00
	15-46090	MISCELLANEOUS INCOME	0.00	0.00	0.00	0.00	0.00	0.00	0.00
		TOTAL MISCELLANEOUS REVENUES	0.00	0.00	0.00	0.00	0.00	0.00	0.00
		TOTAL REVENUES	453,921.00	0.00	0.00	226,960.50	0.00	226,960.50	50.00

TOWN OF MESILLA  
 REVENUE & EXPENSE REPORT (UNAUDITED)  
 AS OF: MARCH 31ST, 2022

15 -AMERICAN RECOVERY FUND  
 COVID 19  
 DEPARTMENTAL EXPENDITURES

FUND	ACCOUNT #	ACCOUNT NAME	CURRENT BUDGET	CURRENT PERIOD	PRIOR YEAR PO ADJUST.	Y-T-D ACTUAL	Y-T-D ENCUMBRANCE	BUDGET BALANCE	% OF BUDGET		
PERSONNEL EXPENSES											
	15-515-1003	FICA/MEDICARE	0.00	0.00	0.00	1,549.26	0.00 (	1,549.26)	0.00		
	15-515-1008	COVID PAY ENHANCEMENTS	0.00	0.00	0.00	20,250.00	0.00 (	20,250.00)	0.00		
		TOTAL PERSONNEL EXPENSES	0.00	0.00	0.00	21,799.26	0.00 (	21,799.26)	0.00		
OPERATING EXPENSES											
	15-515-2241	EQUIPMENT	0.00	18,710.29	0.00	31,693.80	69,486.87 (	101,180.67)	0.00		
	15-515-2597	OTHER EXPENSES	453,921.00	0.00	0.00	0.00	0.00	453,921.00	0.00		
		TOTAL OPERATING EXPENSES	453,921.00	18,710.29	0.00	31,693.80	69,486.87	352,740.33	22.29		
TOTAL COVID 19			453,921.00	18,710.29	0.00	53,493.06	69,486.87	330,941.07	27.09		
TOTAL EXPENDITURES			453,921.00	18,710.29	0.00	53,493.06	69,486.87	330,941.07	27.09		
EXCESS REVENUES/EXPENDITURES			0.00 (	18,710.29)	0.00	173,467.44	(	69,486.87)	(	103,980.57)	0.00
TRANSFERS IN											
	15-48888	TRANSFER IN	0.00	0.00	0.00	0.00	0.00	0.00	0.00		
		TOTAL TRANSFERS IN	0.00	0.00	0.00	0.00	0.00	0.00	0.00		
TRANSFERS OUT											
		TOTAL TRANSFERS OUT	0.00	0.00	0.00	0.00	0.00	0.00	0.00		
NET TRANSFERS			0.00	0.00	0.00	0.00	0.00	0.00	0.00		
REVENUES & TRANSFERS IN OVER/ (UNDER) EXPENDITURES & TRANSFERS OUT			0.00 (	18,710.29)	0.00	173,467.44	(	69,486.87)	(	103,980.57)	0.00

TOWN OF MESILLA  
 REVENUE & EXPENSE REPORT (UNAUDITED)  
 AS OF: MARCH 31ST, 2022

16 -CORRECTIONS FUND

REVENUE

FUND	ACCOUNT #	ACCOUNT NAME	CURRENT BUDGET	CURRENT PERIOD	PRIOR YEAR PO ADJUST.	Y-T-D ACTUAL	Y-T-D ENCUMBRANCE	BUDGET BALANCE	% OF BUDGET
FINES & FORFEITS									
	16-45010	CORRECTION FEES	53,000.00	1,190.34	0.00	11,465.23	0.00	41,534.77	21.63
	16-45040	DWI PREVENTION FEES	340.00	0.00	0.00	75.00	0.00	265.00	22.06
	16-45042	JUDICIAL EDUCATION FEES	7,945.00	178.54	0.00	1,717.06	0.00	6,227.94	21.61
	16-45043	LABORATORY FEES	386.00	0.00	0.00	85.00	0.00	301.00	22.02
	16-45044	COURT AUTOMATION FEES	15,906.00	357.12	0.00	3,439.58	0.00	12,466.42	21.62
		TOTAL FINES & FORFEITS	77,577.00	1,726.00	0.00	16,781.87	0.00	60,795.13	21.63
MISCELLANEOUS REVENUES									
	16-46030	INTEREST	200.00	0.00	0.00	23.85	0.00	176.15	11.93
		TOTAL MISCELLANEOUS REVENUES	200.00	0.00	0.00	23.85	0.00	176.15	11.93
		TOTAL REVENUES	77,777.00	1,726.00	0.00	16,805.72	0.00	60,971.28	21.61

TOWN OF MESILLA  
 REVENUE & EXPENSE REPORT (UNAUDITED)  
 AS OF: MARCH 31ST, 2022

16 -CORRECTIONS FUND

CORRECTIONS  
 DEPARTMENTAL EXPENDITURES

FUND	ACCOUNT #	ACCOUNT NAME	CURRENT BUDGET	CURRENT PERIOD	PRIOR YEAR PO ADJUST.	Y-T-D ACTUAL	Y-T-D ENCUMBRANCE	BUDGET BALANCE	% OF BUDGET
OPERATING EXPENSES									
	16-516-2510	PRISONER CARE	32,000.00	7,552.53	0.00	86,138.31	0.00 (	54,138.31)	269.18
	16-516-2515	AUTO/LAB/DWI/JUD ED	25,000.00	299.80	0.00	4,725.00	0.00	20,275.00	18.90
	16-516-2520	TRANSPORT FEES - COURT		0.00	0.00	0.00	0.00	2,025.00	0.00
	16-516-2598	MISCELLANEOUS	22,975.00	0.00	0.00	0.00	0.00	22,975.00	0.00
		TOTAL OPERATING EXPENSES	82,000.00	7,852.33	0.00	90,863.31	0.00 (	8,863.31)	110.81
CAPITAL OUTLAY									
	16-516-3000	STATE INVESTMENT LOSS	0.00	0.00	0.00	0.00	0.00	0.00	0.00
		TOTAL CAPITAL OUTLAY	0.00	0.00	0.00	0.00	0.00	0.00	0.00
TOTAL CORRECTIONS			82,000.00	7,852.33	0.00	90,863.31	0.00 (	8,863.31)	110.81
TOTAL EXPENDITURES			82,000.00	7,852.33	0.00	90,863.31	0.00 (	8,863.31)	110.81
EXCESS REVENUES/EXPENDITURES			( 4,223.00)	( 6,126.33)	0.00	( 74,057.59)	0.00	69,834.59	753.67
TRANSFERS IN									
	16-48888	TRANSFER IN	0.00	0.00	0.00	0.00	0.00	0.00	0.00
	16-48889	TRANSFER IN/INVESTMENTS	0.00	0.00	0.00	0.00	0.00	0.00	0.00
		TOTAL TRANSFERS IN	0.00	0.00	0.00	0.00	0.00	0.00	0.00
TRANSFERS OUT									
	16-516-4444	TRANSFER OUT	0.00	0.00	0.00	0.00	0.00	0.00	0.00
		TOTAL TRANSFERS OUT	0.00	0.00	0.00	0.00	0.00	0.00	0.00
NET TRANSFERS			0.00	0.00	0.00	0.00	0.00	0.00	0.00
REVENUES & TRANSFERS IN OVER/ (UNDER) EXPENDITURES & TRANSFERS OUT			( 4,223.00)	( 6,126.33)	0.00	( 74,057.59)	0.00	69,834.59	753.67

TOWN OF MESILLA  
 REVENUE & EXPENSE REPORT (UNAUDITED)  
 AS OF: MARCH 31ST, 2022

18 -LAW ENFORCEMENT FUND

REVENUE

FUND	ACCOUNT #	ACCOUNT NAME	CURRENT BUDGET	CURRENT PERIOD	PRIOR YEAR PO ADJUST.	Y-T-D ACTUAL	Y-T-D ENCUMBRANCE	BUDGET BALANCE	% OF BUDGET
TAXES - STATE									
	18-42520	TRANSPORT FEES - COURT	1,000.00	0.00	0.00	0.00	0.00	1,000.00	0.00
		TOTAL TAXES - STATE	1,000.00	0.00	0.00	0.00	0.00	1,000.00	0.00
MISCELLANEOUS REVENUES									
	18-46090	MISCELLANEOUS INCOME	0.00	0.00	0.00	0.00	0.00	0.00	0.00
	18-46500	PROCEEDS FROM ISSUANCE OF DE	0.00	0.00	0.00	0.00	0.00	0.00	0.00
		TOTAL MISCELLANEOUS REVENUES	0.00	0.00	0.00	0.00	0.00	0.00	0.00
INTER-GOV/GRANTS									
	18-47045	STATE ALLOTMENT	23,600.00	0.00	0.00	3,977.00	0.00	19,623.00	16.85
		TOTAL INTER-GOV/GRANTS	23,600.00	0.00	0.00	3,977.00	0.00	19,623.00	16.85
		TOTAL REVENUES	24,600.00	0.00	0.00	3,977.00	0.00	20,623.00	16.17

TOWN OF MESILLA  
 REVENUE & EXPENSE REPORT (UNAUDITED)  
 AS OF: MARCH 31ST, 2022

18 -LAW ENFORCEMENT FUND  
 LAW ENFORCEMENT  
 DEPARTMENTAL EXPENDITURES

FUND	ACCOUNT #	ACCOUNT NAME	CURRENT BUDGET	CURRENT PERIOD	PRIOR YEAR PO ADJUST.	Y-T-D ACTUAL	Y-T-D ENCUMBRANCE	BUDGET BALANCE	% OF BUDGET
OPERATING EXPENSES									
	18-518-2240	VEHICLE R&M	3,977.00	0.00	0.00	1,105.76	0.00	2,871.24	27.80
	18-518-2241	EQUIPMENT R & M	0.00	0.00	0.00	0.00	0.00	0.00	0.00
	18-518-2410	EQUIPMENT PURCHASES	0.00	0.00	0.00	0.00	0.00	0.00	0.00
	18-518-2520	EMPLOYEE TRAINING	0.00	0.00	0.00	0.00	0.00	0.00	0.00
	18-518-2597	OTHER EXPENSES	0.00	0.00	0.00	0.00	0.00	0.00	0.00
		TOTAL OPERATING EXPENSES	3,977.00	0.00	0.00	1,105.76	0.00	2,871.24	27.80
CAPITAL OUTLAY									
	18-518-3050	CAPITOL OUTLAY	0.00	0.00	0.00	0.00	0.00	0.00	0.00
	18-518-3052	NMFA DEBT	19,623.00	0.00	0.00	0.00	0.00	19,623.00	0.00
		TOTAL CAPITAL OUTLAY	19,623.00	0.00	0.00	0.00	0.00	19,623.00	0.00
		TOTAL LAW ENFORCEMENT	23,600.00	0.00	0.00	1,105.76	0.00	22,494.24	4.69
		TOTAL EXPENDITURES	23,600.00	0.00	0.00	1,105.76	0.00	22,494.24	4.69
		EXCESS REVENUES/EXPENDITURES	1,000.00	0.00	0.00	2,871.24	0.00 (	1,871.24)	287.12
TRANSFERS IN									
	18-48888	TRANSFER IN	0.00	0.00	0.00	0.00	0.00	0.00	0.00
		TOTAL TRANSFERS IN	0.00	0.00	0.00	0.00	0.00	0.00	0.00
TRANSFERS OUT									
	18-518-4002	DEBT SERVICE INTEREST	0.00	0.00	0.00	0.00	0.00	0.00	0.00
	18-518-4444	TRANSFER OUT	0.00	0.00	0.00	0.00	0.00	0.00	0.00
		TOTAL TRANSFERS OUT	0.00	0.00	0.00	0.00	0.00	0.00	0.00
		NET TRANSFERS	0.00	0.00	0.00	0.00	0.00	0.00	0.00
		REVENUES & TRANSFERS IN OVER/ (UNDER) EXPENDITURES & TRANSFERS OUT	1,000.00	0.00	0.00	2,871.24	0.00 (	1,871.24)	287.12

TOWN OF MESILLA  
 REVENUE & EXPENSE REPORT (UNAUDITED)  
 AS OF: MARCH 31ST, 2022

20 -COURT AUTOMATION FUND

REVENUE			CURRENT	CURRENT	PRIOR YEAR	Y-T-D	Y-T-D	BUDGET	% OF
FUND	ACCOUNT #	ACCOUNT NAME	BUDGET	PERIOD	PO ADJUST.	ACTUAL	ENCUMBRANCE	BALANCE	BUDGET
MISCELLANEOUS REVENUES									
	20-46060	COURT AUTOMATION GRANT	6,000.00	0.00	0.00	708.99	0.00	5,291.01	11.82
		TOTAL MISCELLANEOUS REVENUES	6,000.00	0.00	0.00	708.99	0.00	5,291.01	11.82
		TOTAL REVENUES	6,000.00	0.00	0.00	708.99	0.00	5,291.01	11.82



TOWN OF MESILLA  
 REVENUE & EXPENSE REPORT (UNAUDITED)  
 AS OF: MARCH 31ST, 2022

20 -COURT AUTOMATION FUND  
 COURT AUTOMATION  
 DEPARTMENTAL EXPENDITURES

FUND	ACCOUNT #	ACCOUNT NAME	CURRENT BUDGET	CURRENT PERIOD	PRIOR YEAR PO ADJUST.	Y-T-D ACTUAL	Y-T-D ENCUMBRANCE	BUDGET BALANCE	% OF BUDGET
CAPITAL OUTLAY									
	20-520-3050	CAPITAL OUTLAY	6,000.00	153.36	0.00	459.13	0.00	5,540.87	7.65
		TOTAL CAPITAL OUTLAY	6,000.00	153.36	0.00	459.13	0.00	5,540.87	7.65
-----									
		TOTAL COURT AUTOMATION	6,000.00	153.36	0.00	459.13	0.00	5,540.87	7.65
		TOTAL EXPENDITURES	6,000.00	153.36	0.00	459.13	0.00	5,540.87	7.65
-----									
		EXCESS REVENUES/EXPENDITURES	0.00	( 153.36)	0.00	249.86	0.00	( 249.86)	0.00
-----									
TRANSFERS IN									
	20-48888	TRANSFER IN	0.00	0.00	0.00	0.00	0.00	0.00	0.00
		TOTAL TRANSFERS IN	0.00	0.00	0.00	0.00	0.00	0.00	0.00
TRANSFERS OUT									
	20-520-4444	TRANSFER OUT	0.00	0.00	0.00	0.00	0.00	0.00	0.00
		TOTAL TRANSFERS OUT	0.00	0.00	0.00	0.00	0.00	0.00	0.00
		NET TRANSFERS	0.00	0.00	0.00	0.00	0.00	0.00	0.00
REVENUES & TRANSFERS IN OVER/ (UNDER) EXPENDITURES & TRANSFERS OUT									
			0.00	( 153.36)	0.00	249.86	0.00	( 249.86)	0.00
-----									

TOWN OF MESILLA  
 REVENUE & EXPENSE REPORT (UNAUDITED)  
 AS OF: MARCH 31ST, 2022

21 -TOWN HALL PROJECT

REVENUE			CURRENT	CURRENT	PRIOR YEAR	Y-T-D	Y-T-D	BUDGET	% OF
FUND	ACCOUNT #	ACCOUNT NAME	BUDGET	PERIOD	PO ADJUST.	ACTUAL	ENCUMBRANCE	BALANCE	BUDGET
TAXES - LOCAL									
	21-41040	MUNICIPAL INFRASTRUCTURE GRT	47,135.00	137.27	0.00	629.93	0.00	46,505.07	1.34
	21-41055	MUNICIPAL C/O GRT	30,900.00	274.54	0.00	1,259.85	0.00	29,640.15	4.08
		TOTAL TAXES - LOCAL	78,035.00	411.81	0.00	1,889.78	0.00	76,145.22	2.42
MISCELLANEOUS REVENUES									
	21-46030	INTEREST	200.00	0.00	0.00	40.96	0.00	159.04	20.48
	21-46090	MISC PROCEEDS	0.00	0.00	0.00	0.00	0.00	0.00	0.00
		TOTAL MISCELLANEOUS REVENUES	200.00	0.00	0.00	40.96	0.00	159.04	20.48
		TOTAL REVENUES	78,235.00	411.81	0.00	1,930.74	0.00	76,304.26	2.47

TOWN OF MESILLA  
 REVENUE & EXPENSE REPORT (UNAUDITED)  
 AS OF: MARCH 31ST, 2022

21 -TOWN HALL PROJECT  
 TOWN HALL PROJECT  
 DEPARTMENTAL EXPENDITURES

FUND	ACCOUNT #	ACCOUNT NAME	CURRENT BUDGET	CURRENT PERIOD	PRIOR YEAR PO ADJUST.	Y-T-D ACTUAL	Y-T-D ENCUMBRANCE	BUDGET BALANCE	% OF BUDGET
OPERATING EXPENSES									
	21-521-2205	BUILDING MAINTENANCE	0.00	0.00	0.00	0.00	0.00	0.00	0.00
		TOTAL OPERATING EXPENSES	0.00	0.00	0.00	0.00	0.00	0.00	0.00
TOTAL TOWN HALL PROJECT									
			0.00	0.00	0.00	0.00	0.00	0.00	0.00
TOTAL EXPENDITURES									
			0.00	0.00	0.00	0.00	0.00	0.00	0.00
EXCESS REVENUES/EXPENDITURES									
			78,235.00	411.81	0.00	1,930.74	0.00	76,304.26	2.47
TRANSFERS IN									
	21-48888	TRANSFER IN	0.00	0.00	0.00	0.00	0.00	0.00	0.00
	21-48889	TRANSFER IN/INVESTMENTS	0.00	0.00	0.00	0.00	0.00	0.00	0.00
		TOTAL TRANSFERS IN	0.00	0.00	0.00	0.00	0.00	0.00	0.00
TRANSFERS OUT									
	21-521-4001	DEBT SERVICE PRINCIPAL	21,441.00	0.00	0.00	0.00	0.00	21,441.00	0.00
	21-521-4002	DEBT SERVICE INTEREST	24,996.00	0.00	0.00	0.00	0.00	24,996.00	0.00
	21-521-4444	TRANSFERS OUT	0.00	0.00	0.00	0.00	0.00	0.00	0.00
		TOTAL TRANSFERS OUT	46,437.00	0.00	0.00	0.00	0.00	46,437.00	0.00
NET TRANSFERS									
			( 46,437.00)	0.00	0.00	0.00	0.00	( 46,437.00)	0.00
REVENUES & TRANSFERS IN OVER/ (UNDER) EXPENDITURES & TRANSFERS OUT									
			31,798.00	411.81	0.00	1,930.74	0.00	29,867.26	6.07

TOWN OF MESILLA  
 REVENUE & EXPENSE REPORT (UNAUDITED)  
 AS OF: MARCH 31ST, 2022

23 -WATER SERVICES FUND

REVENUE

FUND	ACCOUNT #	ACCOUNT NAME	CURRENT BUDGET	CURRENT PERIOD	PRIOR YEAR PO ADJUST.	Y-T-D ACTUAL	Y-T-D ENCUMBRANCE	BUDGET BALANCE	% OF BUDGET
CHARGES FOR SERVICES									
	23-44080	WATER SERVICES	335,356.00	47,177.30	0.00	276,445.90	0.00	58,910.10	82.43
	23-44081	WATER CONNECTIONS FEES	8,500.00	1,050.00	0.00	3,650.00	0.00	4,850.00	42.94
	23-44082	WATER SERVICES PENALTY	2,700.00	0.00	0.00	947.97	0.00	1,752.03	35.11
	23-44083	UTILITY DEPOSITS RECEIVED	0.00	0.00	0.00	0.00	0.00	0.00	0.00
		TOTAL CHARGES FOR SERVICES	346,556.00	48,227.30	0.00	281,043.87	0.00	65,512.13	81.10
MISCELLANEOUS REVENUES									
	23-46030	INTEREST	209.00	0.00	0.00	257.82	0.00	48.82	123.36
	23-46090	MISCELLANEOUS INCOME	2,376.00	841.61	0.00	1,525.00	0.00	851.00	64.18
	23-46100	UNAPPLIED CREDITS	2,000.00	( 1,064.41)	0.00	4,074.51	0.00	2,074.51	203.73
		TOTAL MISCELLANEOUS REVENUES	4,585.00	( 222.80)	0.00	5,857.33	0.00	1,272.33	127.75
INTER-GOV/GRANTS									
	23-47030	EXCAVATION/BORING PERMIT	2,500.00	0.00	0.00	1,200.00	0.00	1,300.00	48.00
		TOTAL INTER-GOV/GRANTS	2,500.00	0.00	0.00	1,200.00	0.00	1,300.00	48.00
		TOTAL REVENUES	353,641.00	48,004.50	0.00	288,101.20	0.00	65,539.80	81.47

TOWN OF MESILLA  
 REVENUE & EXPENSE REPORT (UNAUDITED)  
 AS OF: MARCH 31ST, 2022

23 -WATER SERVICES FUND  
 WATER OPERATIONS  
 DEPARTMENTAL EXPENDITURES

FUND	ACCOUNT #	ACCOUNT NAME	CURRENT BUDGET	CURRENT PERIOD	PRIOR YEAR PO ADJUST.	Y-T-D ACTUAL	Y-T-D ENCUMBRANCE	BUDGET BALANCE	% OF BUDGET
PERSONNEL EXPENSES									
	23-510-1001	SALARIES	93,440.00	4,898.07	0.00	53,525.14	2,464.80	37,450.06	59.92
	23-510-1003	FICA/MEDICARE	7,148.00	369.24	0.00	3,392.95	0.00	3,755.05	47.47
	23-510-1004	PERA/ICMA	8,926.00	480.03	0.00	4,507.72	0.00	4,418.28	50.50
	23-510-1005	HEALTH & LIFE INSURANCE	31,565.00	732.34	0.00	10,459.48	0.00	21,105.52	33.14
	23-510-1006	WORKERS' COMPENSATION	3,803.00	5.75	0.00	587.20	0.00	3,215.80	15.44
	23-510-1007	UNEMPLOYMENT INSURANCE	3,831.00	0.00	0.00	0.00	0.00	3,831.00	0.00
	23-510-1008	OVERTIME ALLOTMENT	2,500.00	160.08	0.00	1,821.04	0.00	678.96	72.84
		TOTAL PERSONNEL EXPENSES	151,213.00	6,645.51	0.00	74,293.53	2,464.80	74,454.67	50.76
OPERATING EXPENSES									
	23-510-2110	OVERTIME ALLOTMENT	0.00	0.00	0.00	0.00	0.00	0.00	0.00
	23-510-2240	VEHICLE R & M	4,589.00	53.22	0.00	3,202.19	0.00	1,386.81	69.78
	23-510-2241	EQUIPMENT R & M	9,800.00	322.51	0.00	8,395.08	730.00	674.92	93.11
	23-510-2253	WATER LINE R & M	4,000.00	0.00	0.00	11,031.89	0.00	( 7,031.89)	275.80
	23-510-2320	AGREEMENTS/CONTRACTS	24,300.00	639.96	0.00	19,762.90	0.00	4,537.10	81.33
	23-510-2405	OFFICE SUPPLIES	600.00	1,550.09	0.00	2,783.84	499.44	( 2,683.28)	547.21
	23-510-2410	EQUIPMENT/SUPPLIES	9,500.00	1,290.26	0.00	5,988.25	0.00	3,511.75	63.03
	23-510-2415	SAFETY EQUIPMENT	1,800.00	203.11	0.00	932.03	0.00	867.97	51.78
	23-510-2420	UNIFORM ALLOWANCE	1,500.00	210.60	0.00	1,729.54	0.00	( 229.54)	115.30
	23-510-2430	CHEMICALS	3,275.00	0.00	0.00	4,087.30	0.00	( 812.30)	124.80
	23-510-2530	INSURANCE	24,700.00	0.00	0.00	24,697.83	0.00	2.17	99.99
	23-510-2535	POSTAGE	3,100.00	370.99	0.00	3,406.55	0.00	( 306.55)	109.89
	23-510-2540	PRINT/PUBLISH/ADVERTISE	2,300.00	0.00	0.00	485.13	0.00	1,814.87	21.09
	23-510-2545	GRT TO NM	0.00	0.00	0.00	0.00	0.00	0.00	0.00
	23-510-2546	CONSERVATION FEES TO NM	3,200.00	171.75	0.00	2,549.79	0.00	650.21	79.68
	23-510-2560	EQUIPMENT RENTAL	500.00	309.77	0.00	309.77	0.00	190.23	61.95
	23-510-2570	DUES/SUBSCRIPTIONS	1,400.00	270.33	0.00	1,655.32	0.00	( 255.32)	118.24
	23-510-2575	TELEPHONE	6,100.00	1,018.71	0.00	7,068.60	0.00	( 968.60)	115.88
	23-510-2580	UTILITIES	24,500.00	1,339.59	0.00	18,644.02	0.00	5,855.98	76.10
	23-510-2581	METER REPLACEMENT PROGRAM	4,400.00	1,800.00	0.00	4,802.48	0.00	( 402.48)	109.15
	23-510-2585	FUEL	4,000.00	0.00	0.00	5,652.88	0.00	( 1,652.88)	141.32
	23-510-2598	MISCELLANEOUS	1,500.00	0.00	0.00	2,081.25	0.00	( 581.25)	138.75
	23-510-2599	DEPRECIATION EXPENSE	0.00	0.00	0.00	0.00	0.00	0.00	0.00
		TOTAL OPERATING EXPENSES	135,064.00	9,550.89	0.00	129,266.64	1,229.44	4,567.92	96.62
CAPITAL OUTLAY									
	23-510-3050	CAPITAL OUTLAY	38,613.00	0.00	0.00	24,424.84	0.00	14,188.16	63.26
		TOTAL CAPITAL OUTLAY	38,613.00	0.00	0.00	24,424.84	0.00	14,188.16	63.26
TOTAL WATER OPERATIONS									
			324,890.00	16,196.40	0.00	227,985.01	3,694.24	93,210.75	71.31
TOTAL EXPENDITURES									
			324,890.00	16,196.40	0.00	227,985.01	3,694.24	93,210.75	71.31
EXCESS REVENUES/EXPENDITURES									
			28,751.00	31,808.10	0.00	60,116.19	( 3,694.24)	( 27,670.95)	196.24

TOWN OF MESILLA  
 REVENUE & EXPENSE REPORT (UNAUDITED)  
 AS OF: MARCH 31ST, 2022

24 - WASTEWATER SERVICES FUND

REVENUE

FUND	ACCOUNT #	ACCOUNT NAME	CURRENT BUDGET	CURRENT PERIOD	PRIOR YEAR PO ADJUST.	Y-T-D ACTUAL	Y-T-D ENCUMBRANCE	BUDGET BALANCE	% OF BUDGET
CHARGES FOR SERVICES									
	24-44080	WASTEWATER SERVICES	184,675.00	28,446.07	0.00	150,865.92	0.00	33,809.08	81.69
	24-44081	WASTEWATER CONNECTIONS FEES	18,200.00	0.00	0.00	2,250.00	0.00	15,950.00	12.36
	24-44082	SEWER SERVICES PENALTY	2,020.00	0.00	0.00	512.92	0.00	1,507.08	25.39
		TOTAL CHARGES FOR SERVICES	204,895.00	28,446.07	0.00	153,628.84	0.00	51,266.16	74.98
MISCELLANEOUS REVENUES									
	24-46030	INTEREST	300.00	0.00	0.00	0.00	0.00	300.00	0.00
	24-46090	MISCELLANEOUS INCOME	8,700.00	0.00	0.00	11,481.40	0.00 (	2,781.40)	131.97
		TOTAL MISCELLANEOUS REVENUES	9,000.00	0.00	0.00	11,481.40	0.00 (	2,481.40)	127.57
		TOTAL REVENUES	213,895.00	28,446.07	0.00	165,110.24	0.00	48,784.76	77.19

TOWN OF MESILLA  
REVENUE & EXPENSE REPORT (UNAUDITED)  
AS OF: MARCH 31ST, 2022

24 -WASTEWATER SERVICES FUND  
WASTEWATER OPERATIONS  
DEPARTMENTAL EXPENDITURES

FUND	ACCOUNT #	ACCOUNT NAME	CURRENT BUDGET	CURRENT PERIOD	PRIOR YEAR PO ADJUST.	Y-T-D ACTUAL	Y-T-D ENCUMBRANCE	BUDGET BALANCE	% OF BUDGET
PERSONNEL EXPENSES									
	24-510-1001	SALARIES	34,760.00	1,193.85	0.00	11,262.27	0.00	23,497.73	32.40
	24-510-1003	FICA/MEDICARE	2,889.00	0.00	0.00	0.00	0.00	2,889.00	0.00
	24-510-1004	PERA/ICMA	3,406.00	0.00	0.00	0.00	0.00	3,406.00	0.00
	24-510-1005	HEALTH & LIFE INSURANCE	80.00	0.00	0.00	0.00	0.00	80.00	0.00
	24-510-1006	WORKERS' COMPENSATION	1,085.00	0.00	0.00	572.25	0.00	512.75	52.74
	24-510-1007	UNEMPLOYMENT INSURANCE	988.00	0.00	0.00	0.00	0.00	988.00	0.00
	24-510-1008	OVERTIME ALLOTMENT	3,000.00	0.00	0.00	0.00	0.00	3,000.00	0.00
		TOTAL PERSONNEL EXPENSES	46,208.00	1,193.85	0.00	11,834.52	0.00	34,373.48	25.61
OPERATING EXPENSES									
	24-510-2240	VEHICLE R & M	5,500.00	0.00	0.00	5,022.02	0.00	477.98	91.31
	24-510-2242	EQUIPMENT R&M	0.00	0.00	0.00	0.00	0.00	0.00	0.00
	24-510-2251	PUMP R & M	15,000.00	9.74	0.00	1,287.23	0.00	13,712.77	8.58
	24-510-2253	SEWER LINE R & M	11,989.00	207.72	0.00	2,931.31	0.00	9,057.69	24.45
	24-510-2322	SEWER LINE CLEANING	27,000.00	0.00	0.00	16,196.63	7,137.25	3,666.12	86.42
	24-510-2325	CLC FEES	92,619.00	7,778.31	0.00	62,217.64	0.00	30,401.36	67.18
	24-510-2326	CLC CONNECTION FEES	14,000.00	0.00	0.00	1,943.00	0.00	12,057.00	13.88
	24-510-2415	SAFETY EQUIPMENT	1,800.00	120.06	0.00	796.01	0.00	1,003.99	44.22
	24-510-2420	UNIFORM ALLOWANCE	1,600.00	0.00	0.00	841.39	0.00	758.61	52.59
	24-510-2430	CHEMICALS	11,569.00	2,800.00	0.00	8,597.89	0.00	2,971.11	74.32
	24-510-2540	PRINT/PUBLISH/ADVERTISE	1,600.00	0.00	0.00	0.00	0.00	1,600.00	0.00
	24-510-2575	TELEPHONE	2,100.00	37.78	0.00	302.24	0.00	1,797.76	14.39
	24-510-2580	UTILITIES	900.00	0.00	0.00	406.15	0.00	493.85	45.13
	24-510-2585	FUEL	4,000.00	0.00	0.00	0.00	0.00	4,000.00	0.00
		TOTAL OPERATING EXPENSES	189,677.00	10,953.61	0.00	100,541.51	7,137.25	81,998.24	56.77
CAPITAL OUTLAY									
	24-510-3050	CAPITAL OUTLAY	0.00	0.00	0.00	0.00	0.00	0.00	0.00
		TOTAL CAPITAL OUTLAY	0.00	0.00	0.00	0.00	0.00	0.00	0.00
TOTAL WASTEWATER OPERATIONS									
			235,885.00	12,147.46	0.00	112,376.03	7,137.25	116,371.72	50.67
TOTAL EXPENDITURES									
			235,885.00	12,147.46	0.00	112,376.03	7,137.25	116,371.72	50.67
EXCESS REVENUES/EXPENDITURES									
			( 21,990.00)	16,298.61	0.00	52,734.21	( 7,137.25)	( 67,586.96)	207.35-

TOWN OF MESILLA  
 REVENUE & EXPENSE REPORT (UNAUDITED)  
 AS OF: MARCH 31ST, 2022

25 -DEBT SERVICE FUND

REVENUE

FUND	ACCOUNT #	ACCOUNT NAME	CURRENT BUDGET	CURRENT PERIOD	PRIOR YEAR PO ADJUST.	Y-T-D ACTUAL	Y-T-D ENCUMBRANCE	BUDGET BALANCE	% OF BUDGET
TAXES - LOCAL									
	25-41020	ADMIN FEES	0.00	0.00	0.00	0.00	0.00	0.00	0.00
	25-41040	MUNICIPAL GRT	32,532.00	6,173.40	0.00	21,606.90	0.00	10,925.10	66.42
		TOTAL TAXES - LOCAL	32,532.00	6,173.40	0.00	21,606.90	0.00	10,925.10	66.42
MISCELLANEOUS REVENUES									
	25-46030	INTEREST	76,838.00	0.00	0.00	0.00	0.00	76,838.00	0.00
	25-46060	MESILLA 9 MARSHAL CARS	0.00	0.00	0.00	0.00	0.00	0.00	0.00
	25-46090	MISC LOAN REVENUE	0.00	0.00	0.00	0.00	0.00	0.00	0.00
		TOTAL MISCELLANEOUS REVENUES	76,838.00	0.00	0.00	0.00	0.00	76,838.00	0.00
		TOTAL REVENUES	109,370.00	6,173.40	0.00	21,606.90	0.00	87,763.10	19.76



TOWN OF MESILLA  
 REVENUE & EXPENSE REPORT (UNAUDITED)  
 AS OF: MARCH 31ST, 2022

25 --DEBT SERVICE FUND  
 FIRE TRUCK LOAN - NMFA  
 DEPARTMENTAL EXPENDITURES

FUND	ACCOUNT #	ACCOUNT NAME	CURRENT BUDGET	CURRENT PERIOD	PRIOR YEAR PO ADJUST.	Y-T-D ACTUAL	Y-T-D ENCUMBRANCE	BUDGET BALANCE	% OF BUDGET
OPERATING EXPENSES									
	25-525-2240	GRT ADMIN FEES	0.00	0.00	0.00	0.00	0.00	0.00	0.00
	25-525-2320	NMFA PAYMENT 2846-PP	32,532.00	6,173.40	0.00	21,606.90	0.00	10,925.10	66.42
	25-525-2420	MESILLA 9 MARSHAL LOAN	0.00	0.00	0.00	0.00	0.00	0.00	0.00
		TOTAL OPERATING EXPENSES	32,532.00	6,173.40	0.00	21,606.90	0.00	10,925.10	66.42
TOTAL FIRE TRUCK LOAN - NMFA									
			32,532.00	6,173.40	0.00	21,606.90	0.00	10,925.10	66.42
TOTAL EXPENDITURES									
			32,532.00	6,173.40	0.00	21,606.90	0.00	10,925.10	66.42
EXCESS REVENUES/EXPENDITURES									
			76,838.00	0.00	0.00	0.00	0.00	76,838.00	0.00
TRANSFERS IN									
	25-48888	TRANSFER IN	76,838.00	0.00	0.00	0.00	0.00	76,838.00	0.00
		TOTAL TRANSFERS IN	76,838.00	0.00	0.00	0.00	0.00	76,838.00	0.00
TRANSFERS OUT									
	25-525-4001	DEBT SERVICE PRINCIPAL	0.00	0.00	0.00	0.00	0.00	0.00	0.00
	25-525-4002	DEBT SERVICE INTEREST	0.00	0.00	0.00	0.00	0.00	0.00	0.00
	25-525-4021	NMFA 3413-PP MARSHAL CARS	0.00	0.00	0.00	0.00	0.00	0.00	0.00
	25-525-4444	TRANSFER OUT	0.00	0.00	0.00	0.00	0.00	0.00	0.00
		TOTAL TRANSFERS OUT	0.00	0.00	0.00	0.00	0.00	0.00	0.00
NET TRANSFERS									
			76,838.00	0.00	0.00	0.00	0.00	76,838.00	0.00
REVENUES & TRANSFERS IN OVER/ (UNDER) EXPENDITURES & TRANSFERS OUT									
			153,676.00	0.00	0.00	0.00	0.00	153,676.00	0.00



TOWN OF MESILLA  
 REVENUE & EXPENSE REPORT (UNAUDITED)  
 AS OF: MARCH 31ST, 2022

26 -LODGER'S TAX FUND  
 LODGER'S TAX  
 DEPARTMENTAL EXPENDITURES

FUND	ACCOUNT #	ACCOUNT NAME	CURRENT BUDGET	CURRENT PERIOD	PRIOR YEAR PO ADJUST.	Y-T-D ACTUAL	Y-T-D ENCUMBRANCE	BUDGET BALANCE	% OF BUDGET
OPERATING EXPENSES									
	26-526-2411	COMMUNITY PROGRAMS	1,000.00	0.00	0.00	500.00	0.00	500.00	50.00
	26-526-2525	TOURISM MATCHING	7,250.00	0.00	0.00	4,262.86	0.00	2,987.14	58.80
	26-526-2526	TOURISM PROMOTION	5,750.00	0.00	0.00	0.00	0.00	5,750.00	0.00
		TOTAL OPERATING EXPENSES	14,000.00	0.00	0.00	4,762.86	0.00	9,237.14	34.02
TOTAL LODGER'S TAX									
			14,000.00	0.00	0.00	4,762.86	0.00	9,237.14	34.02
TOTAL EXPENDITURES									
			14,000.00	0.00	0.00	4,762.86	0.00	9,237.14	34.02
EXCESS REVENUES/EXPENDITURES									
			0.00	2,796.34	0.00	14,993.58	0.00 (	14,993.58)	0.00
TRANSFERS IN									
	26-48888	TRANSFER IN	0.00	0.00	0.00	0.00	0.00	0.00	0.00
		TOTAL TRANSFERS IN	0.00	0.00	0.00	0.00	0.00	0.00	0.00
TRANSFERS OUT									
	26-526-4444	TRANSFER OUT	0.00	0.00	0.00	0.00	0.00	0.00	0.00
		TOTAL TRANSFERS OUT	0.00	0.00	0.00	0.00	0.00	0.00	0.00
NET TRANSFERS									
			0.00	0.00	0.00	0.00	0.00	0.00	0.00
REVENUES & TRANSFERS IN OVER/ (UNDER) EXPENDITURES & TRANSFERS OUT									
			0.00	2,796.34	0.00	14,993.58	0.00 (	14,993.58)	0.00

TOWN OF MESILLA  
 REVENUE & EXPENSE REPORT (UNAUDITED)  
 AS OF: MARCH 31ST, 2022

27 -ROAD FUND

REVENUE

FUND	ACCOUNT #	ACCOUNT NAME	CURRENT BUDGET	CURRENT PERIOD	PRIOR YEAR PO ADJUST.	Y-T-D ACTUAL	Y-T-D ENCUMBRANCE	BUDGET BALANCE	% OF BUDGET
TAXES - STATE									
	27-42030	GASOLINE TAX/MUNI ROAD	5,154.12	417.00	0.00	3,336.00	0.00	1,818.12	64.72
	27-42040	GASOLINE TAX/COUNTY ROAD	25.75	0.45	0.00	42.55	0.00	16.80	165.24
		TOTAL TAXES - STATE	5,179.87	417.45	0.00	3,378.55	0.00	1,801.32	65.22
MISCELLANEOUS REVENUES									
	27-46090	MISCELLANEOUS INCOME	0.00	0.00	0.00	0.00	0.00	0.00	0.00
		TOTAL MISCELLANEOUS REVENUES	0.00	0.00	0.00	0.00	0.00	0.00	0.00
INTER-GOV/GRANTS									
	27-47068	OLD LGRF & ROAD FUND PROJECT	2.00	0.00	0.00	0.00	0.00	2.00	0.00
	27-47069	CALLE PARIAN CN 1193343	75,000.00	0.00	0.00	75,000.00	0.00	0.00	100.00
	27-47070	LGRF PICACHO CASTILLO ARENAL	40,000.00	0.00	0.00	40,000.00	0.00	0.00	100.00
	27-47072	LGRF PRINCIPAL,SANTIAGO, OES	0.00	0.00	0.00	0.00	0.00	0.00	0.00
	27-47080	PLAZA SIDEWALK IMPS	117,000.00	0.00	0.00	0.00	0.00	117,000.00	0.00
	27-47081	SAP CALLE PICACHO DRAIN	180,000.00	0.00	0.00	0.00	0.00	180,000.00	0.00
	27-47082	STREET LIGHT IMPS	125,000.00	0.00	0.00	0.00	0.00	125,000.00	0.00
	27-47085	TRAIL LGTPF PHS II	844,000.00	0.00	0.00	0.00	0.00	844,000.00	0.00
		TOTAL INTER-GOV/GRANTS	1,381,002.00	0.00	0.00	115,000.00	0.00	1,266,002.00	8.33
		TOTAL REVENUES	1,386,181.87	417.45	0.00	118,378.55	0.00	1,267,803.32	8.54

TOWN OF MESILLA  
REVENUE & EXPENSE REPORT (UNAUDITED)  
AS OF: MARCH 31ST, 2022

27 -ROAD FUND

ROAD FUND  
DEPARTMENTAL EXPENDITURES

FUND	ACCOUNT #	ACCOUNT NAME	CURRENT BUDGET	CURRENT PERIOD	PRIOR YEAR PO ADJUST.	Y-T-D ACTUAL	Y-T-D ENCUMBRANCE	BUDGET BALANCE	% OF BUDGET
OPERATING EXPENSES									
	27-527-2231	STREET R&M	5,000.00	109.53	0.00	9,377.53	0.00	( 4,377.53)	187.55
	27-527-2232	STREET SIGNS	19,122.83	0.00	0.00	17,994.63	0.00	1,128.20	94.10
	27-527-2233	STREET STRIPING	500.00	152.25	0.00	152.25	0.00	347.75	30.45
	27-527-2234	BOWMAN CN118263 ID C2633	0.00	0.00	0.00	0.00	0.00	0.00	0.00
	27-527-2235	LGRF SP-1-19(966, HW2L100	0.00	0.00	0.00	0.00	0.00	0.00	0.00
	27-527-2315	CALLE PARIAN CAPITAL OUTL	0.00	0.00	0.00	0.00	0.00	0.00	0.00
	27-527-2330	MISC STREET IMPROVEMENTS	0.00	0.00	0.00	0.00	0.00	0.00	0.00
	27-527-2430	PRIOR YEAR LGRF & ROAD PR	107,531.00	0.00	0.00	0.00	0.00	107,531.00	0.00
	27-527-2520	LGRF PICACHO, CASTILLO, A	34,121.76	0.00	0.00	34,121.76	0.00	0.00	100.00
	27-527-2530	LGRF PRINCIPAL, SANTIAGO,	0.00	0.00	0.00	0.00	0.00	0.00	0.00
	27-527-2540	PLAZA SIDEWALK IMPS	117,000.00	0.00	0.00	0.00	21,410.30	95,589.70	18.30
	27-527-2542	SAP CALLE PICACHO DRAIN	180,000.00	0.00	0.00	0.00	31,698.94	148,301.06	17.61
	27-527-2543	CALLE PICACHO TPF NMDOT	0.00	0.00	0.00	0.00	50,857.00	( 50,857.00)	0.00
	27-527-2544	MESILLA STREET LGT IMPS	125,000.00	8,123.44	0.00	8,123.44	116,747.18	129.38	99.90
	27-527-2546	TRAIL LGTPF PHS II	844,000.00	0.00	0.00	65,040.91	0.00	778,959.09	7.71
		TOTAL OPERATING EXPENSES	1,432,275.59	8,385.22	0.00	134,810.52	220,713.42	1,076,751.65	24.82
CAPITAL OUTLAY									
	27-527-3010	MISCELLANEOUS	5,000.00	0.00	0.00	0.00	0.00	5,000.00	0.00
		TOTAL CAPITAL OUTLAY	5,000.00	0.00	0.00	0.00	0.00	5,000.00	0.00
TOTAL ROAD FUND									
			1,437,275.59	8,385.22	0.00	134,810.52	220,713.42	1,081,751.65	24.74
TOTAL EXPENDITURES									
			1,437,275.59	8,385.22	0.00	134,810.52	220,713.42	1,081,751.65	24.74
EXCESS REVENUES/EXPENDITURES									
			( 51,093.72)	( 7,967.77)	0.00	( 16,431.97)	( 220,713.42)	186,051.67	464.14
TRANSFERS IN									
	27-48888	TRANSFER IN	33,748.00	0.00	0.00	0.00	0.00	33,748.00	0.00
		TOTAL TRANSFERS IN	33,748.00	0.00	0.00	0.00	0.00	33,748.00	0.00
TRANSFERS OUT									
	27-527-4444	TRANSFER OUT	0.00	0.00	0.00	( 130,000.00)	0.00	130,000.00	0.00
		TOTAL TRANSFERS OUT	0.00	0.00	0.00	( 130,000.00)	0.00	130,000.00	0.00
NET TRANSFERS									
			33,748.00	0.00	0.00	130,000.00	0.00	( 96,252.00)	385.21

TOWN OF MESILLA  
REVENUE & EXPENSE REPORT (UNAUDITED)  
AS OF: MARCH 31ST, 2022

27 -ROAD FUND

ROAD FUND

DEPARTMENTAL EXPENDITURES

FUND	ACCOUNT #	ACCOUNT NAME	CURRENT BUDGET	CURRENT PERIOD	PRIOR YEAR PO ADJUST.	Y-T-D ACTUAL	Y-T-D ENCUMBRANCE	BUDGET BALANCE	% OF BUDGET
REVENUES & TRANSFERS IN OVER/									
(UNDER) EXPENDITURES & TRANSFERS OUT (									
			17,345.72)	7,967.77)	0.00	113,568.03	( 220,713.42)	89,799.67	617.71
			=====	=====	=====	=====	=====	=====	=====

3

TOWN OF MESILLA  
 REVENUE & EXPENSE REPORT (UNAUDITED)  
 AS OF: MARCH 31ST, 2022

28 -SOLID WASTE FUND

REVENUE

FUND	ACCOUNT #	ACCOUNT NAME	CURRENT BUDGET	CURRENT PERIOD	PRIOR YEAR PO ADJUST.	Y-T-D ACTUAL	Y-T-D ENCUMBRANCE	BUDGET BALANCE	% OF BUDGET
TAXES - LOCAL									
	28-41020	ENVIRONMENTAL GRT	24,116.88	68.28	0.00	314.01	0.00	23,802.87	1.30
	TOTAL TAXES - LOCAL		24,116.88	68.28	0.00	314.01	0.00	23,802.87	1.30
CHARGES FOR SERVICES									
	28-44080	SOLID WASTE SERVICES	220,177.00	41,637.30	0.00	188,235.79	0.00	31,941.21	85.49
	28-44082	SOLID WASTE SERVICES PENALTY	3,400.00	0.00	0.00	596.53	0.00	2,803.47	17.55
	TOTAL CHARGES FOR SERVICES		223,577.00	41,637.30	0.00	188,832.32	0.00	34,744.68	84.46
MISCELLANEOUS REVENUES									
	28-46030	INTEREST	100.00	0.00	0.00	18.34	0.00	81.66	18.34
	28-46090	MISCELLANEOUS	3,000.00	0.00	0.00	0.00	0.00	3,000.00	0.00
	TOTAL MISCELLANEOUS REVENUES		3,100.00	0.00	0.00	18.34	0.00	3,081.66	0.59
TOTAL REVENUES			250,793.88	41,705.58	0.00	189,164.67	0.00	61,629.21	75.43

TOWN OF MESILLA  
REVENUE & EXPENSE REPORT (UNAUDITED)  
AS OF: MARCH 31ST, 2022

28 -SOLID WASTE FUND  
OPERATING EXPENSES  
DEPARTMENTAL EXPENDITURES

FUND	ACCOUNT #	ACCOUNT NAME	CURRENT BUDGET	CURRENT PERIOD	PRIOR YEAR PO ADJUST.	Y-T-D ACTUAL	Y-T-D ENCUMBRANCE	BUDGET BALANCE	% OF BUDGET
PERSONNEL EXPENSES									
	28-510-1001	SALARIES	124,500.00	9,174.07	0.00	77,451.01	0.00	47,048.99	62.21
	28-510-1003	FICA/MEDICARE	7,283.00	712.50	0.00	5,938.56	0.00	1,344.44	81.54
	28-510-1004	PERA/ICMA	8,939.00	876.26	0.00	7,229.82	0.00	1,709.18	80.88
	28-510-1005	HEALTH & LIFE INSURANCE	13,000.00	733.00	0.00	6,539.28	0.00	6,460.72	50.30
	28-510-1006	WORKERS' COMPENSATION	2,231.00	10.35	0.00	598.70	0.00	1,632.30	26.84
	28-510-1007	UNEMPLOYMENT INSURANCE	1,992.00	0.00	0.00	0.00	0.00	1,992.00	0.00
	28-510-1008	OVERTIME ALLOTMENT	3,000.00	397.28	0.00	2,470.67	0.00	529.33	82.36
		TOTAL PERSONNEL EXPENSES	160,945.00	11,903.46	0.00	100,228.04	0.00	60,716.96	62.27
OPERATING EXPENSES									
	28-510-2110	TRAVEL/CONF/TRAINING	1,500.00	0.00	0.00	550.74	0.00	949.26	36.72
	28-510-2205	OVERTIME ALLOTMENT	0.00	0.00	0.00	0.00	0.00	0.00	0.00
	28-510-2240	VEHCILE R&M	5,500.00	0.00	0.00	3,950.66	0.00	1,549.34	71.83
	28-510-2241	EQUIPMENT R&M	10,791.06	3,687.10	0.00	9,619.46	0.00	1,171.60	89.14
	28-510-2320	AGREEMENTS/CONTRACTS	140,099.00	14,694.39	0.00	133,942.54	0.00	6,156.46	95.61
	28-510-2323	SPEC EVENTS TRASH SVC	800.00	0.00	0.00	215.05	0.00	584.95	26.88
	28-510-2324	CLC LANDFILL	711.00	6.70	0.00	195.25	0.00	515.75	27.46
	28-510-2405	MAINTENANCE SUPPLIES	2,000.00	0.00	0.00	668.89	0.00	1,331.11	33.44
	28-510-2415	SAFETY EQUIPMENT	1,000.00	43.33	0.00	292.49	0.00	707.51	29.25
	28-510-2420	UNIFORM ALLOWANCE	2,000.00	465.90	0.00	2,115.54	0.00	115.54	105.78
	28-510-2425	CLEANING SUPPLIES	6,000.00	1,078.67	0.00	2,634.29	0.00	3,365.71	43.90
	28-510-2430	CHEMICALS	5,000.00	80.00	0.00	1,932.63	0.00	3,067.37	38.65
	28-510-2535	POSTAGE	500.00	0.00	0.00	0.00	0.00	500.00	0.00
	28-510-2540	PRINT/PUBLISH/ADVERTISE	500.00	0.00	0.00	0.00	0.00	500.00	0.00
	28-510-2545	GRT TO NM	0.00	0.00	0.00	0.00	0.00	0.00	0.00
	28-510-2575	TELEPHONE	3,000.00	37.78	0.00	302.24	0.00	2,697.76	10.07
	28-510-2585	FUEL	5,000.00	922.93	0.00	2,959.90	0.00	2,040.10	59.20
	28-510-2598	MISCELLANEOUS	0.00	0.00	0.00	0.00	0.00	0.00	0.00
		TOTAL OPERATING EXPENSES	184,401.06	21,016.80	0.00	159,379.68	0.00	25,021.38	86.43
CAPITAL OUTLAY									
	28-510-3050	CAPITAL OUTLAY	0.00	0.00	0.00	0.00	0.00	0.00	0.00
		TOTAL CAPITAL OUTLAY	0.00	0.00	0.00	0.00	0.00	0.00	0.00
TOTAL OPERATING EXPENSES			345,346.06	32,920.26	0.00	259,607.72	0.00	85,738.34	75.17
TOTAL EXPENDITURES			345,346.06	32,920.26	0.00	259,607.72	0.00	85,738.34	75.17
EXCESS REVENUES/EXPENDITURES			{ 94,552.18}	8,785.32	0.00	{ 70,443.05}	0.00	{ 24,109.13}	74.50





TOWN OF MESILLA  
 REVENUE & EXPENSE REPORT (UNAUDITED)  
 AS OF: MARCH 31ST, 2022

29 -SCHOOL RESOURCE OFFICER  
 SCHOOL RESOURCE OFFICER  
 DEPARTMENTAL EXPENDITURES

FUND	ACCOUNT #	ACCOUNT NAME	CURRENT BUDGET	CURRENT PERIOD	PRIOR YEAR PO ADJUST.	Y-T-D ACTUAL	Y-T-D ENCUMBRANCE	BUDGET BALANCE	% OF BUDGET
PERSONNEL EXPENSES									
	29-529-1001	SRO SALARIES	73,596.00	5,003.60	0.00	38,301.53	0.00	35,294.47	52.04
	29-529-1003	FICA/MEDICARE	5,630.00	411.31	0.00	2,987.32	0.00	2,642.68	53.06
	29-529-1004	P.E.R.A.	14,094.00	918.14	0.00	7,127.77	0.00	6,966.23	50.57
	29-529-1005	HEALTH & LIFE INSURANCE	34,664.00	1,364.40	0.00	12,284.02	0.00	22,379.98	35.44
	29-529-1006	WORKER'S COMPENSATION	2,844.00	4.60	0.00	2,095.38	0.00	748.62	73.68
	29-529-1007	UNEMPLOYMENT INSURANCE	1,994.00	0.00	0.00	0.00	0.00	1,994.00	0.00
	29-529-1008	OVERTIME	1,500.00	0.00	0.00	54.25	0.00	1,445.75	3.62
		TOTAL PERSONNEL EXPENSES	134,322.00	7,702.05	0.00	62,850.27	0.00	71,471.73	46.79
TOTAL SCHOOL RESOURCE OFFICER									
			134,322.00	7,702.05	0.00	62,850.27	0.00	71,471.73	46.79
TOTAL EXPENDITURES									
			134,322.00	7,702.05	0.00	62,850.27	0.00	71,471.73	46.79
EXCESS REVENUES/EXPENDITURES									
			( 19,596.00)	( 7,702.05)	0.00	( 5,486.77)	0.00	( 14,109.23)	28.00
TRANSFERS IN									
	29-48888	TRANSFERS IN	18,095.00	0.00	0.00	0.00	0.00	18,095.00	0.00
		TOTAL TRANSFERS IN	18,095.00	0.00	0.00	0.00	0.00	18,095.00	0.00
TRANSFERS OUT									
	29-529-4444	TRANSFER OUT	0.00	0.00	0.00	0.00	0.00	0.00	0.00
		TOTAL TRANSFERS OUT	0.00	0.00	0.00	0.00	0.00	0.00	0.00
NET TRANSFERS									
			18,095.00	0.00	0.00	0.00	0.00	18,095.00	0.00
REVENUES & TRANSFERS IN OVER/ (UNDER) EXPENDITURES & TRANSFERS OUT									
			( 1,501.00)	( 7,702.05)	0.00	( 5,486.77)	0.00	3,985.77	365.54

TOWN OF MESILLA  
 REVENUE & EXPENSE REPORT (UNAUDITED)  
 AS OF: MARCH 31ST, 2022

30 -EVENTS FUND

REVENUE

FUND	ACCOUNT #	ACCOUNT NAME	CURRENT BUDGET	CURRENT PERIOD	PRIOR YEAR PO ADJUST.	Y-T-D ACTUAL	Y-T-D ENCUMBRANCE	BUDGET BALANCE	% OF BUDGET
CHARGES FOR SERVICES									
	30-44070	RENTALS	20,300.00	4,105.00	0.00	10,195.00	0.00	10,105.00	50.22
		TOTAL CHARGES FOR SERVICES	20,300.00	4,105.00	0.00	10,195.00	0.00	10,105.00	50.22
MISCELLANEOUS REVENUES									
	30-46090	MISCELLANEOUS INCOME	0.00	100.00	0.00	100.00	0.00 (	100.00)	0.00
		TOTAL MISCELLANEOUS REVENUES	0.00	100.00	0.00	100.00	0.00 (	100.00)	0.00
		TOTAL REVENUES	20,300.00	4,205.00	0.00	10,295.00	0.00	10,005.00	50.71

TOWN OF MESILLA  
 REVENUE & EXPENSE REPORT (UNAUDITED)  
 AS OF: MARCH 31ST, 2022

30 -EVENTS FUND

EVENTS FUND  
 DEPARTMENTAL EXPENDITURES

FUND	ACCOUNT #	ACCOUNT NAME	CURRENT BUDGET	CURRENT PERIOD	PRIOR YEAR PO ADJUST.	Y-T-D ACTUAL	Y-T-D ENCUMBRANCE	BUDGET BALANCE	% OF BUDGET
OPERATING EXPENSES									
	30-530-2530	FIESTA REFUNDS	0.00	0.00	0.00	525.00	0.00 (	525.00)	0.00
	TOTAL OPERATING EXPENSES		0.00	0.00	0.00	525.00	0.00 (	525.00)	0.00
CAPITAL OUTLAY									
	30-530-3062	VENDOR AGREE/CONTRACTS	10,700.00	0.00	0.00	5,090.00	0.00	5,610.00	47.57
	30-530-3082	MISCELLANEOUS	9,600.00	0.00	0.00	10,498.71	0.00 (	898.71)	109.36
	TOTAL CAPITAL OUTLAY		20,300.00	0.00	0.00	15,588.71	0.00	4,711.29	76.79
<hr/>									
	TOTAL EVENTS FUND		20,300.00	0.00	0.00	16,113.71	0.00	4,186.29	79.38
<hr/>									
	TOTAL EXPENDITURES		20,300.00	0.00	0.00	16,113.71	0.00	4,186.29	79.38
<hr/>									
	EXCESS REVENUES/EXPENDITURES		0.00	4,205.00	0.00 (	5,818.71)	0.00	5,818.71	0.00
<hr/>									
TRANSFERS IN									
	30-48888	TRANSFER IN	0.00	0.00	0.00	0.00	0.00	0.00	0.00
	TOTAL TRANSFERS IN		0.00	0.00	0.00	0.00	0.00	0.00	0.00
<hr/>									
TRANSFERS OUT									
	TOTAL TRANSFERS OUT		0.00	0.00	0.00	0.00	0.00	0.00	0.00
<hr/>									
	NET TRANSFERS		0.00	0.00	0.00	0.00	0.00	0.00	0.00
<hr/>									
	REVENUES & TRANSFERS IN OVER/ (UNDER) EXPENDITURES & TRANSFERS OUT		0.00	4,205.00	0.00 (	5,818.71)	0.00	5,818.71	0.00
<hr/>									

TOWN OF MESILLA  
 REVENUE & EXPENSE REPORT (UNAUDITED)  
 AS OF: MARCH 31ST, 2022

32 -PARKING FUND

REVENUE

FUND	ACCOUNT #	ACCOUNT NAME	CURRENT BUDGET	CURRENT PERIOD	PRIOR YEAR PO ADJUST.	Y-T-D ACTUAL	Y-T-D ENCUMBRANCE	BUDGET BALANCE	% OF BUDGET
MISCELLANEOUS REVENUES									
	32-46020	PARKING FEE DEPOSITS	6,000.00	3,715.00	0.00	5,865.00	0.00	135.00	97.75
	32-46090	MISCELLANEOUS DEPOSITS	0.00	0.00	0.00	0.00	0.00	0.00	0.00
		TOTAL MISCELLANEOUS REVENUES	6,000.00	3,715.00	0.00	5,865.00	0.00	135.00	97.75
TOTAL REVENUES			6,000.00	3,715.00	0.00	5,865.00	0.00	135.00	97.75
TOTAL EXPENDITURES			0.00	0.00	0.00	0.00	0.00	0.00	0.00
EXCESS REVENUES/EXPENDITURES			6,000.00	3,715.00	0.00	5,865.00	0.00	135.00	97.75
TRANSFERS OUT									
		TOTAL TRANSFERS OUT	0.00	0.00	0.00	0.00	0.00	0.00	0.00
NET TRANSFERS			0.00	0.00	0.00	0.00	0.00	0.00	0.00
REVENUES & TRANSFERS IN OVER/ (UNDER) EXPENDITURES & TRANSFERS OUT									
			6,000.00	3,715.00	0.00	5,865.00	0.00	135.00	97.75

TOWN OF MESILLA  
 REVENUE & EXPENSE REPORT (UNAUDITED)  
 AS OF: MARCH 31ST, 2022

33 -MUNICIPAL COURT BONDS

REVENUE

FUND	ACCOUNT #	ACCOUNT NAME	CURRENT BUDGET	CURRENT PERIOD	PRIOR YEAR PO ADJUST.	Y-T-D ACTUAL	Y-T-D ENCUMBRANCE	BUDGET BALANCE	% OF BUDGET
MISCELLANEOUS REVENUES									
	33-46020	BOND DEPOSITS	9,000.00 (	618.00)	0.00 (	9,221.00)	0.00	18,221.00	102.46-
	33-46090	MISCELLANEOUS INCOME	0.00	0.00	0.00	7,198.00	0.00 (	7,198.00)	0.00
		TOTAL MISCELLANEOUS REVENUES	9,000.00 (	618.00)	0.00 (	2,023.00)	0.00	11,023.00	22.48-
		TOTAL REVENUES	9,000.00 (	618.00)	0.00 (	2,023.00)	0.00	11,023.00	22.48-

TOWN OF MESILLA  
 REVENUE & EXPENSE REPORT (UNAUDITED)  
 AS OF: MARCH 31ST, 2022

33 -MUNICIPAL COURT BONDS  
 COURT BONDS  
 DEPARTMENTAL EXPENDITURES

FUND	ACCOUNT #	ACCOUNT NAME	CURRENT BUDGET	CURRENT PERIOD	PRIOR YEAR PO ADJUST.	Y-T-D ACTUAL	Y-T-D ENCUMBRANCE	BUDGET BALANCE	% OF BUDGET
CAPITAL OUTLAY									
	33-533-3301	COURT REFUNDS/PAYMENTS	9,000.00	0.00	0.00 (	5,365.00)	0.00	14,365.00	59.61-
		TOTAL CAPITAL OUTLAY	9,000.00	0.00	0.00 (	5,365.00)	0.00	14,365.00	59.61-
-----									
		TOTAL COURT BONDS	9,000.00	0.00	0.00 (	5,365.00)	0.00	14,365.00	59.61-
		TOTAL EXPENDITURES	9,000.00	0.00	0.00 (	5,365.00)	0.00	14,365.00	59.61-
-----									
		EXCESS REVENUES/EXPENDITURES	0.00 (	618.00)	0.00	3,342.00	0.00 (	3,342.00)	0.00
-----									
TRANSFERS OUT									
	33-533-4444	TRANSFER OUT	0.00	0.00	0.00	0.00	0.00	0.00	0.00
		TOTAL TRANSFERS OUT	0.00	0.00	0.00	0.00	0.00	0.00	0.00
		NET TRANSFERS	0.00	0.00	0.00	0.00	0.00	0.00	0.00
REVENUES & TRANSFERS IN OVER/ (UNDER) EXPENDITURES & TRANSFERS OUT									
			0.00 (	618.00)	0.00	3,342.00	0.00 (	3,342.00)	0.00
-----									





TOWN OF MESILLA  
 REVENUE & EXPENSE REPORT (UNAUDITED)  
 AS OF: MARCH 31ST, 2022

35 -CAPITAL IMPROVEMENTS FUND

CAPITAL IMPROVEMENTS

DEPARTMENTAL EXPENDITURES

FUND	ACCOUNT #	ACCOUNT NAME	CURRENT BUDGET	CURRENT PERIOD	PRIOR YEAR PO ADJUST.	Y-T-D ACTUAL	Y-T-D ENCUMBRANCE	BUDGET BALANCE	% OF BUDGET
CAPITAL OUTLAY									
35-535-3559		PLAZA LIGHTING CAPITAL OU	71,000.00	0.00	0.00	2,723.07	70,569.99 (	2,293.06)	103.23
35-535-3560		SCADA SYSTEM	100,000.00	0.00	0.00	0.00	25,507.59	74,492.41	25.51
35-535-3561		MARSHAL'S EQUIP CAPITAL O	50.00	0.00	0.00	0.00	0.00	50.00	0.00
35-535-3562		20-E3389 MARSHAL'S CARS/E	110,000.00	0.00	0.00	103,436.00	0.00	6,564.00	94.03
35-535-3563		WATER TRUST BOARD 159,199	2,000.00	0.00	0.00	0.00	0.00	2,000.00	0.00
35-535-3564		20-E2124-STB BOOSTER STAT	320,000.00	0.00	0.00	29,051.18	0.00	290,948.82	9.08
35-535-3565		UNIVERSITY WATER LINE REP	2,000.00	0.00	0.00	0.00	60,477.00 (	58,477.00)	23.85
35-535-3566		CAPITAL OUTLAY- PLAYGROUN	123,000.00	0.00	0.00	123,000.00	0.00	0.00	100.00
35-535-3567		OLD CAPITAL OUTLAY PROJEC	192,000.00	0.00	0.00	0.00	0.00	192,000.00	0.00
35-535-3568		ADELANTE PROJECTS	75,000.00	0.00	0.00	0.00	0.00	75,000.00	0.00
35-535-3570		LA LLORONA MATCHING FUNDS	0.00	0.00	0.00	0.00	0.00	0.00	0.00
35-535-3572		SIDEWALK/EASEMENTS IMPRV	0.00	0.00	0.00	28,705.69	0.00 (	28,705.69)	0.00
		TOTAL CAPITAL OUTLAY	995,050.00	0.00	0.00	286,915.94	156,554.58	551,579.48	44.57
TOTAL CAPITAL IMPROVEMENTS									
			995,050.00	0.00	0.00	286,915.94	156,554.58	551,579.48	44.57
TOTAL EXPENDITURES									
			995,050.00	0.00	0.00	286,915.94	156,554.58	551,579.48	44.57
EXCESS REVENUES/EXPENDITURES									
			( 56,000.00)	0.00	0.00 (	183,186.42)	( 156,554.58)	283,741.00	606.68
TRANSFERS IN									
35-48888		TRANSFER IN	50,000.00	0.00	0.00 (	130,000.00)	0.00	180,000.00	260.00-
		TOTAL TRANSFERS IN	50,000.00	0.00	0.00 (	130,000.00)	0.00	180,000.00	260.00-
TRANSFERS OUT									
35-535-4444		TRANSFER OUT	50,000.00	0.00	0.00	0.00	0.00	50,000.00	0.00
		TOTAL TRANSFERS OUT	50,000.00	0.00	0.00	0.00	0.00	50,000.00	0.00
NET TRANSFERS									
			0.00	0.00	0.00 (	130,000.00)	0.00	130,000.00	0.00
REVENUES & TRANSFERS IN OVER/ (UNDER) EXPENDITURES & TRANSFERS OUT (									
			56,000.00)	0.00	0.00 (	313,186.42)	( 156,554.58)	413,741.00	838.82

TOWN OF MESILLA FIRE DEPARTMENT  
MONTHLY BOT REPORT



DATE: MARCH, 2022

---

MAJOR ADDITIONS TO INVENTORY

10 sets of dual certified wildland/extrication PPE. Replaces 15 to 20 year old gear.

MAINTENANCE OF EQUIPMENT

Two LifePak 12 cardiac monitors calibrated, tested and certified. Quarterly Pharmacy inspection completed with no issues. SCBA air bottles compression station serviced, tested and certified. Holmatro extrication gear tested with repairs made to hydraulic resevoir. Blades on cutting tool replaced. Engine 31 door latch replaces after door kept opening while in motion. Squad 32 engine block heater replaced along with shoreline connection. New batteries were also placed in Squad 32. Two 4-gas detectors sent for calibration and repair.

COMMENTS

Deputy Chief Evans has been appointed as an ambassador to the National Volunteer Fire Counsel Daily Forum. Chief Evans will be answering questions and weighing in on a variety of topics concerning the volunteer fire service in our country. Fire Marshal Greg Whited has been elected as First Vice President to the New Mexico Chapter of the International Association of Arson Investigators. Two of our firefighters passed the National Registry of EMTs registry exam and are currently awaiting the NM licenses. The department conducted a precribed burn with personnle from the Mesilla Valley Bosque Stated Park to reduce a fuel load issue in the park. 2.6 acres of slash and brush were burned without incident. The opprotunity was taken to also do training and pratical hands on experience with fire containment, fire line construction and fire behavior.

SUBMITTED BY

Fire Chief Kevin Hoban \_\_\_\_\_



# Mesilla Fire Department

Mesilla, NM

This report was generated on 4/4/2022 11:37:03 AM



## Incident Statistics

Zone(s): All Zones | Start Date: 03/01/2022 | End Date: 03/31/2022

INCIDENT COUNT			
INCIDENT TYPE		# INCIDENTS	
EMS		40	
FIRE		21	
<b>TOTAL</b>		<b>61</b>	
TOTAL TRANSPORTS (N2 and N3)			
APPARATUS	# of APPARATUS	# of PATIENT TRANSPORTS	TOTAL # of PATIENT
Bat31	0	0	9
Bat32	0	0	3
E31	0	0	2
SQ32	0	0	15
<b>TOTAL</b>	<b>0</b>	<b>0</b>	<b>29</b>
PRE-INCIDENT VALUE		LOSSES	
<b>\$0.00</b>		<b>\$0.00</b>	
CO CHECKS			
<b>TOTAL</b>			
MUTUAL AID			
Aid Type		Total	
Aid Given		13	
Aid Received		1	
OVERLAPPING CALLS			
# OVERLAPPING		% OVERLAPPING	
18		29.51	
LIGHTS AND SIREN - AVERAGE RESPONSE TIME (Dispatch to Arrival)			
Station	EMS	FIRE	
Mesilla Fire Main Station 31	0:09:49	0:18:10	
Mesilla FMO	0:05:59		
<b>AVERAGE FOR ALL CALLS</b>		<b>0:10:29</b>	
LIGHTS AND SIREN - AVERAGE TURNOUT TIME (Dispatch to Enroute)			
Station	EMS	FIRE	
Mesilla Fire Main Station 31	0:01:56	0:06:47	
Mesilla FMO	0:01:05		
<b>AVERAGE FOR ALL CALLS</b>		<b>0:02:29</b>	
AGENCY	AVERAGE TIME ON SCENE (MM:SS)		
Mesilla Fire Department	52:13		

Only Reviewed Incidents included. EMS for Incident counts includes only 300 to 399 Incident Types. All other incident types are counted as FIRE. CO Checks only includes Incident Types: 424, 736 and 734. # Apparatus Transports = # of incide

# Mesilla Fire Department

Mesilla, NM

This report was generated on 4/4/2022 12:21:42 PM



## Breakdown by Major Incident Types for Date Range

Zone(s): All Zones | Start Date: 03/01/2022 | End Date: 03/31/2022

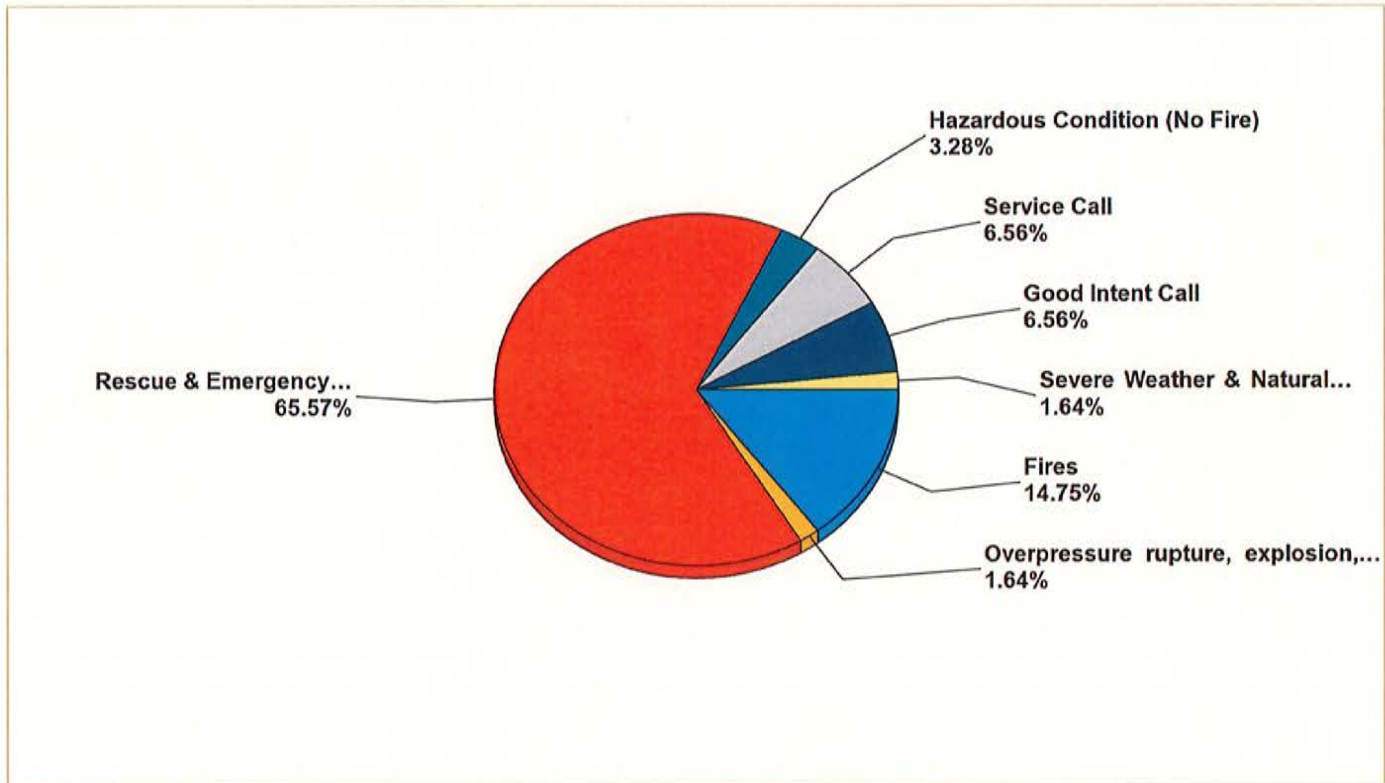

MAJOR INCIDENT TYPE	# INCIDENTS	% of TOTAL
Fires	9	14.75%
Overpressure rupture, explosion, overheating - no fire	1	1.64%
Rescue & Emergency Medical Service	40	65.57%
Hazardous Condition (No Fire)	2	3.28%
Service Call	4	6.56%
Good Intent Call	4	6.56%
Severe Weather & Natural Disaster	1	1.64%
<b>TOTAL</b>	<b>61</b>	<b>100%</b>

Only REVIEWED and/or LOCKED IMPORTED incidents are included. Summary results for a major incident type are not displayed if the count is zero.



**Detailed Breakdown by Incident Type**

<b>INCIDENT TYPE</b>	<b># INCIDENTS</b>	<b>% of TOTAL</b>
111 - Building fire	1	1.64%
132 - Road freight or transport vehicle fire	1	1.64%
136 - Self-propelled motor home or recreational vehicle	1	1.64%
142 - Brush or brush-and-grass mixture fire	6	9.84%
251 - Excessive heat, scorch burns with no ignition	1	1.64%
311 - Medical assist, assist EMS crew	5	8.2%
320 - Emergency medical service, other	1	1.64%
321 - EMS call, excluding vehicle accident with injury	24	39.34%
322 - Motor vehicle accident with injuries	5	8.2%
381 - Rescue or EMS standby	5	8.2%
412 - Gas leak (natural gas or LPG)	2	3.28%
511 - Lock-out	1	1.64%
522 - Water or steam leak	1	1.64%
551 - Assist police or other governmental agency	1	1.64%
561 - Unauthorized burning	1	1.64%
611 - Dispatched & cancelled en route	1	1.64%
622 - No incident found on arrival at dispatch address	2	3.28%
631 - Authorized controlled burning	1	1.64%
813 - Wind storm, tornado/hurricane assessment	1	1.64%
<b>TOTAL INCIDENTS:</b>	<b>61</b>	<b>100%</b>

Only REVIEWED and/or LOCKED IMPORTED incidents are included. Summary results for a major incident type are not displayed if the count is zero.



# Mesilla Fire Department

Mesilla, NM

This report was generated on 4/4/2022 12:24:14 PM



## Breakdown by Major Incident Types for Date Range

Zone(s): All Zones | Start Date: 01/01/2022 | End Date: 03/31/2022

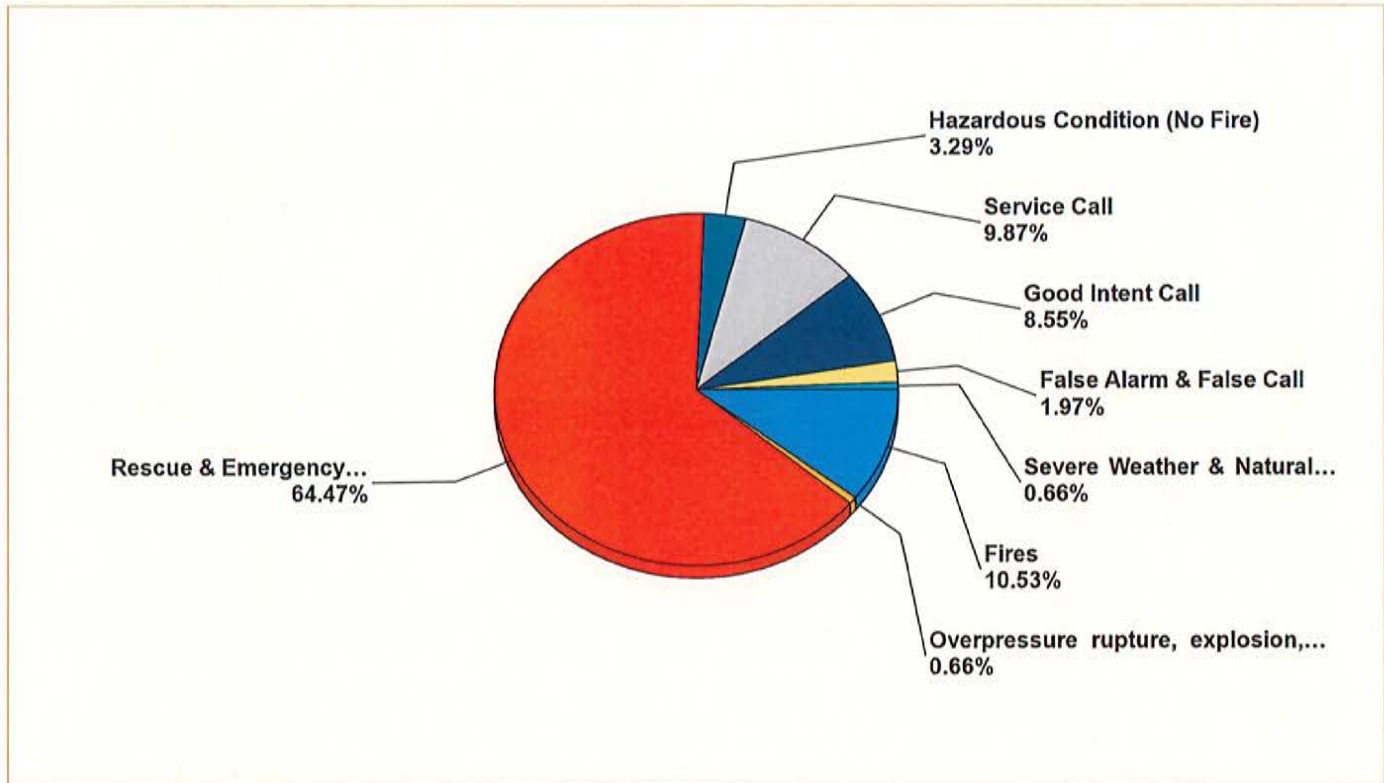

MAJOR INCIDENT TYPE	# INCIDENTS	% of TOTAL
Fires	16	10.53%
Overpressure rupture, explosion, overheating - no fire	1	0.66%
Rescue & Emergency Medical Service	98	64.47%
Hazardous Condition (No Fire)	5	3.29%
Service Call	15	9.87%
Good Intent Call	13	8.55%
False Alarm & False Call	3	1.97%
Severe Weather & Natural Disaster	1	0.66%
<b>TOTAL</b>	<b>152</b>	<b>100%</b>

Only REVIEWED and/or LOCKED IMPORTED incidents are included. Summary results for a major incident type are not displayed if the count is zero.



### Detailed Breakdown by Incident Type

INCIDENT TYPE	# INCIDENTS	% of TOTAL
111 - Building fire	3	1.97%
132 - Road freight or transport vehicle fire	1	0.66%
136 - Self-propelled motor home or recreational vehicle	1	0.66%
142 - Brush or brush-and-grass mixture fire	10	6.58%
143 - Grass fire	1	0.66%
251 - Excessive heat, scorch burns with no ignition	1	0.66%
300 - Rescue, EMS incident, other	1	0.66%
311 - Medical assist, assist EMS crew	9	5.92%
320 - Emergency medical service, other	1	0.66%
321 - EMS call, excluding vehicle accident with injury	62	40.79%
322 - Motor vehicle accident with injuries	11	7.24%
324 - Motor vehicle accident with no injuries.	3	1.97%
381 - Rescue or EMS standby	11	7.24%
400 - Hazardous condition, other	1	0.66%
412 - Gas leak (natural gas or LPG)	3	1.97%
444 - Power line down	1	0.66%
511 - Lock-out	1	0.66%
522 - Water or steam leak	3	1.97%
551 - Assist police or other governmental agency	1	0.66%
553 - Public service	1	0.66%
554 - Assist invalid	7	4.61%
561 - Unauthorized burning	2	1.32%
611 - Dispatched & cancelled en route	7	4.61%
622 - No incident found on arrival at dispatch address	3	1.97%
631 - Authorized controlled burning	1	0.66%
650 - Steam, other gas mistaken for smoke, other	1	0.66%
651 - Smoke scare, odor of smoke	1	0.66%
735 - Alarm system sounded due to malfunction	1	0.66%
743 - Smoke detector activation, no fire - unintentional	2	1.32%
813 - Wind storm, tornado/hurricane assessment	1	0.66%
<b>TOTAL INCIDENTS:</b>	<b>152</b>	<b>100%</b>

Only REVIEWED and/or LOCKED IMPORTED incidents are included. Summary results for a major incident type are not displayed if the count is zero.





# Mesilla Fire Department

Mesilla, NM

This report was generated on 4/4/2022 12:00:07 PM



## Incident Type Count per Zone for Date Range

Start Date: 03/01/2022 | End Date: 03/31/2022

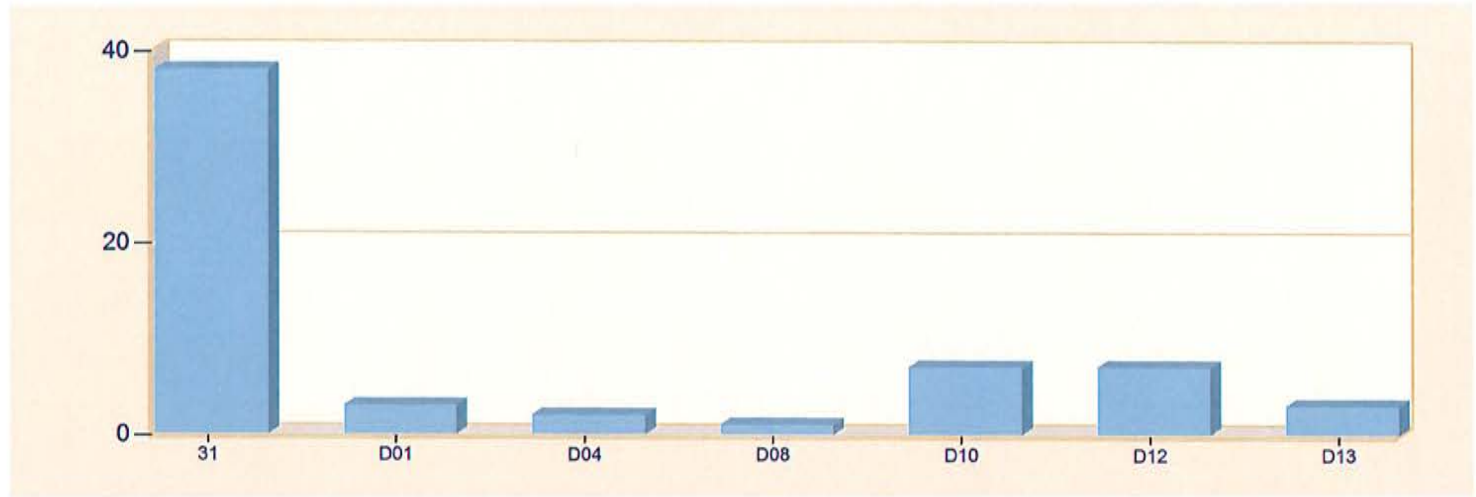

ZONES	INCIDENT TYPE	COUNT
<b>31 - Town of Mesilla</b>		
	142 - Brush or brush-and-grass mixture fire	3
	251 - Excessive heat, scorch burns with no ignition	1
	311 - Medical assist, assist EMS crew	3
	321 - EMS call, excluding vehicle accident with injury	18
	322 - Motor vehicle accident with injuries	3
	381 - Rescue or EMS standby	1
	412 - Gas leak (natural gas or LPG)	2
	511 - Lock-out	1
	522 - Water or steam leak	1
	551 - Assist police or other governmental agency	1
	561 - Unauthorized burning	1
	622 - No incident found on arrival at dispatch address	1
	631 - Authorized controlled burning	1
	813 - Wind storm, tornado/hurricane assessment	1
	<i>Total Incidents for 31 - Town of Mesilla.</i>	38
<b>D01 - Dona Ana</b>		
	311 - Medical assist, assist EMS crew	1
	321 - EMS call, excluding vehicle accident with injury	1
	611 - Dispatched & cancelled en route	1
	<i>Total Incidents for D01 - Dona Ana:</i>	3

Zone information is defined on the Basic Info 3 screen of an incident.  
Only REVIEWED incidents included.



ZONES	INCIDENT TYPE	COUNT
<b>D04 - La Mesa</b>		
	321 - EMS call, excluding vehicle accident with injury	1
	322 - Motor vehicle accident with injuries	1
	<i>Total Incidents for D04 - La Mesa:</i>	2
<b>D08 - Radium Springs</b>		
	142 - Brush or brush-and-grass mixture fire	1
	<i>Total Incidents for D08 - Radium Springs:</i>	1
<b>D10 - Mesquite</b>		
	320 - Emergency medical service, other	1
	321 - EMS call, excluding vehicle accident with injury	1
	381 - Rescue or EMS standby	4
	622 - No incident found on arrival at dispatch address	1
	<i>Total Incidents for D10 - Mesquite:</i>	7
<b>D12 - Fairacres</b>		
	132 - Road freight or transport vehicle fire	1
	142 - Brush or brush-and-grass mixture fire	2
	311 - Medical assist, assist EMS crew	1
	321 - EMS call, excluding vehicle accident with injury	2
	322 - Motor vehicle accident with injuries	1
	<i>Total Incidents for D12 - Fairacres:</i>	7
<b>D13 - South Valley</b>		
	111 - Building fire	1
	136 - Self-propelled motor home or recreational vehicle	1
	321 - EMS call, excluding vehicle accident with injury	1
	<i>Total Incidents for D13 - South Valley:</i>	3
<b>Total Count for all Zone:</b>		<b>61</b>

Zone information is defined on the Basic Info 3 screen of an incident.  
Only REVIEWED incidents included.



# Mesilla Fire Department

Mesilla, NM

This report was generated on 04/04/2022



Response Mode: Lights and Sirens | Start Date: 03/01/2022 | End Date:03/31/2022

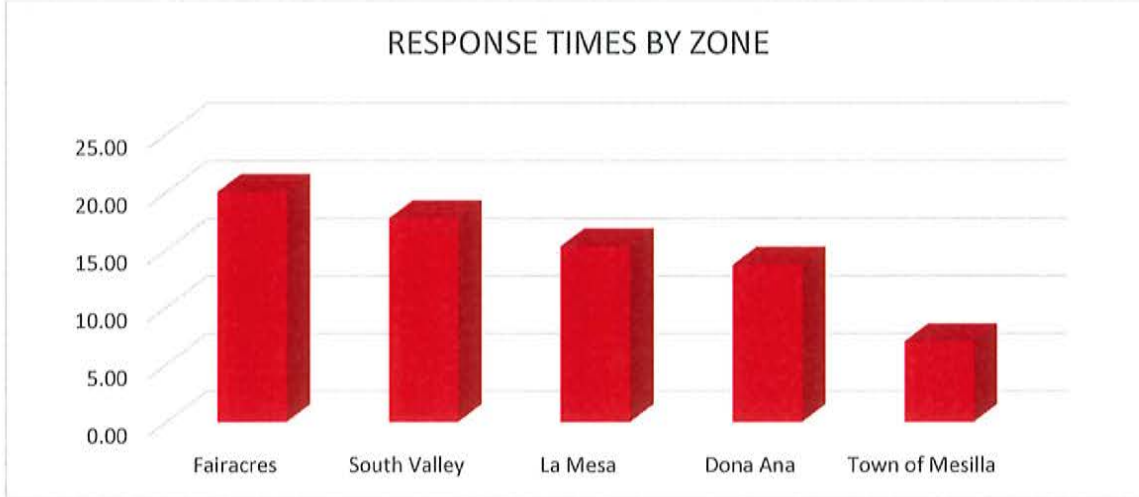

Zone	AVERAGE RESPONSE TIME (in minutes)
Fairacres	20.02
South Valley	17.72
La Mesa	15.29
Dona Ana	13.68
Town of Mesilla	7.01
<b>Town of Mesilla No Crew on Duty</b>	<b>8.66</b>
<b>Town of Mesilla Crew on Duty</b>	<b>3.58</b>

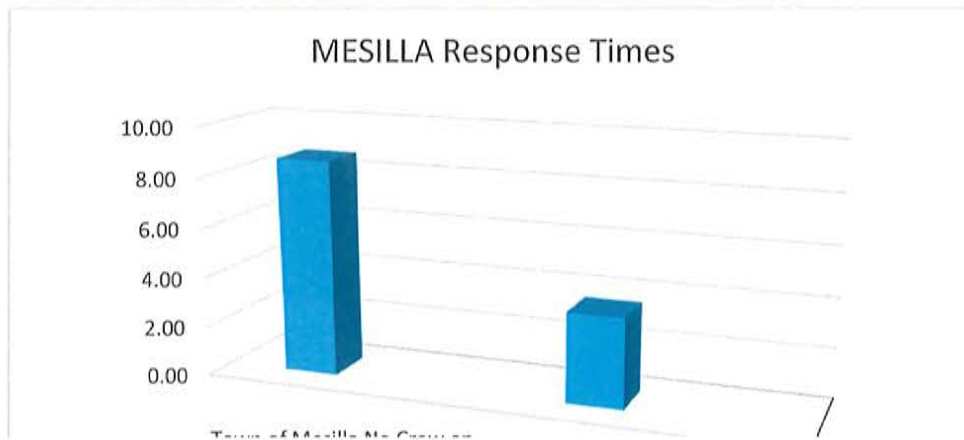

Only REVIEWED incidents included. Response Time is Dispatched to Arrived.

# Mesilla Fire Department

Mesilla, NM

This report was generated on 4/4/2022 12:16:33 PM



## Events per Event Type for Date Range (Landscape)

Start Date: 03/01/2022 | End Date: 03/31/2022

EVENT TYPE	DATE	EVENT NAME	CATEGORY	LOCATION	HOURS	PARTICIPANTS
<b>Daily Operations Shift</b>						
	03/01/2022	C-Shift	Shifts	Firehouse 31	5	Vincent Calderazzo, Crystal Davis-Whited, Patrick Dorr, Andy Embury, Melina Gaytan, Sebastian Linares-Chacon
	03/02/2022	A-Shift	Shifts	Firehouse 31	11.5	Sebastian Linares-Chacon, Humberto Manriquez
	03/04/2022	C Shift	Shifts	Fire House 31	15	Tyler Brown, Humberto Fernandez III, Yvonne Ortiz, Jasha Zapien
	03/08/2022	A-Shift	Shifts	Firehouse 31	18	Vincent Calderazzo, Patrick Dorr, Michael Dove, Melina Gaytan, Sebastian Linares-Chacon, Humberto Manriquez
	03/10/2022	C Shift	Shifts	Fire House 31	14	Tyler Brown, Xavier Sanchez, Jasha Zapien
	03/14/2022	A-Shift	Shifts	Firehouse 31	12	Sebastian Linares-Chacon, Gabriel Rodriguez
	03/15/2022	B Shift	Station Tour	Firehouse 31	24	Travis Rogers
	03/16/2022	C Shift	Shifts	Fire House 31	16	Katrina Arguello, Tyler Brown, Humberto Fernandez III, Trevor Frieze, Xavier Sanchez, Jasha Zapien
	03/17/2022	A-Shift	Shifts	Firestation 31	9	Humberto Manriquez
	03/19/2022	C Shift	Shifts	Fire House 31	16	Tyler Brown, Sergio Fernandez, Humberto Fernandez III, Xavier Sanchez
	03/20/2022	A-Shift	Shifts	Firehouse 31	13	Sebastian Linares-Chacon
	03/21/2022	B-Shift	Shifts	Firehouse 31	3	Sebastian Linares-Chacon
	03/21/2022	B Shift	Shifts	Firehouse 31	24	Travis Rogers

Only LOCKED events included.



emergencyreporting.com

Doc Id: 753

Page # 1 of 3

EVENT TYPE	DATE	EVENT NAME	CATEGORY	LOCATION	HOURS	PARTICIPANTS
	03/25/2022	C Shift	Shifts	Fire House 31	14	Tyler Brown, Sergio Fernandez, Humberto Fernandez III, Xavier Sanchez, Jasha Zapien
	03/28/2022	C Shift	Shifts	Fire House 31	17	Tyler Brown, Humberto Fernandez III, Gabriel Franco, Trevor Frieze, Jasha Zapien
	03/29/2022	A-Shift	Shifts	Firehouse 31	10	Sebastian Linares-Chacon, Gabriel Rodriguez

**Total Hours for Daily Operations Shift: 221.5**

**Administration Shift**

03/02/2022	Administrative Shift Tele-work	Administrative	Tele-work home	2.5	Harry Evans
03/02/2022	Administrative Shift	Administrative	Telework	1	Crystal Davis-Whited
03/04/2022	Administrative Shift	Administrative	Fire House 31	8	Harry Evans
03/13/2022	Administrative Shift	Administrative	Telework	4	Crystal Davis-Whited, Gregory Whited
03/13/2022	Administrative Shift Tele-work	Administrative	Tele-work home	5.5	Harry Evans
03/21/2022	A shift	Shifts	Firehouse 31	3.75	Dylan Thunhorst, Ines Thunhorst
03/24/2022	Administrative Shift	Administrative	Fire House 31	2	Harry Evans
03/29/2022	Administrative Shift	Administrative	Telework	2.25	Crystal Davis-Whited
03/31/2022	Administrative Shift	Administrative	Telework	2	Crystal Davis-Whited

**Total Hours for Administration Shift: 31**

**Prevention Event**

03/02/2022	Architectural Styles meeting	Prevention Event	Town hall	2	Gregory Whited
03/30/2022	Zia Middle School Fire Drill	Fire Drill	Zia Middle School	2	Tyler Brown, Trevor Frieze, Kevin Hoban, George Klebansky, Xavier Sanchez, Gregory Whited, Jasha Zapien
03/30/2022	Zia Middles School Fire Drill	Prevention Event	Zia Middle School	3.5	Tyler Brown, Trevor Frieze, George Klebansky, Xavier Sanchez, Gregory Whited, Jasha Zapien

**Total Hours for Prevention Event: 7.5**

**Special Assignment**

03/07/2022	Hose test	Work Session	Station 31	8	Kevin Hoban, George Klebansky, Gregory Whited
------------	-----------	--------------	------------	---	---

Only LOCKED events included.



EVENT TYPE	DATE	EVENT NAME	CATEGORY	LOCATION	HOURS	PARTICIPANTS
	03/12/2022	Birthday Tour	Station Tour	Bowman St.	1	Trevor Frieze, George Klebansky, Sergio Lucero, Xavier Sanchez, Jasha Zapien

**Total Hours for Special Assignment: 9**

EMS Division Shift						
	03/09/2022	B-Shift	Shifts	Fire station 31	9.5	Dylan Thunhorst, Ines Thunhorst
	03/18/2022	A-Shift	Shifts	Fire station 31	6	Alexander Aguilar, Ines Thunhorst
	03/20/2022	C shift	Shifts	Firehouse 31	2.5	Sergio Mendez, Ines Thunhorst
	03/25/2022	A-Shift	Shifts	Fire station 31	7	Ines Thunhorst
	03/27/2022	B shift	Shifts	Fire station 31	7	Dylan Thunhorst, Ines Thunhorst

**Total Hours for EMS Division Shift: 32**

Only LOCKED events included.



# Mesilla Fire Department

Mesilla, NM

This report was generated on 4/4/2022 12:19:39 PM



## Occupancies Inspected for Date Range

Start Date: 03/01/2022 | End Date: 03/31/2022

OCCUPANCY	ID	ADDRESS	ZONE	LAST INSPECTION
1st National Bank	48	1553 Avenida De Mesilla		03/11/2022
Agave Artists	27	2250 Calle de San Albino		03/11/2022
Andele Restaurant, LLC	9	1950 Calle Del Norte		03/11/2022
Andele Tortilleria	64	1950 Calle Del Norte		03/11/2022
Andele's Dog House	10	1983 Calle Del Norte		03/11/2022
Andeles Fiesta Place	1	1955 Calle del Norte #D		03/11/2022
Edward Jones	33	1740 Calle de Mercado #f		03/11/2022
Las Cruces Bulletin	38	1740 Calle de Mercado #A		03/11/2022
Leavitt Group Southwest Inc	40	1740 Mercado #E		03/11/2022
Paisano Cafe	17	1740 Calle De Mercado #C		03/11/2022
Vigil & Associates	47	1765 Avenida de Mercado		03/11/2022

**# of Occupancies Inspected: 11**

**% Occupancies Inspected: 6.43**

Included occupancies are those that have a LOCKED inspection on record for the date range provided.



emergencyreporting.com  
Doc Id: 727  
Page # 1 of 1

# Mesilla Fire Department

Mesilla, NM

This report was generated on 4/4/2022 11:40:51 AM



## Count of Classes by Personnel by Class Category

Passed/Failed: Both Passed and Failed | Personnel: All Personnel | Start Date: 03/01/2022 | End Date: 03/31/2022

### Aguilar, Alexander J

Class Category	Class Count	Total Class Hours
I.S.O. Company Training	1	3:00
<b>Total for Aguilar, Alexander J</b>	<b>1</b>	<b>3:00</b>

### Arguello, Katrina M

Class Category	Class Count	Total Class Hours
I.S.O. Company Training	2	8:00
I.S.O. Driver and Operator Training	1	3:00
<b>Total for Arguello, Katrina M</b>	<b>3</b>	<b>11:00</b>

### Azcarate, Ben

Class Category	Class Count	Total Class Hours
I.S.O. Officer Training	1	1:00
<b>Total for Azcarate, Ben</b>	<b>1</b>	<b>1:00</b>

### Brown, Tyler S

Class Category	Class Count	Total Class Hours
EMS Training	3	6:50
I.S.O. Company Training	7	15:00
I.S.O. Driver and Operator Training	1	3:00
<b>Total for Brown, Tyler S</b>	<b>11</b>	<b>24:50</b>

### Calderazzo, Vincent S

Class Category	Class Count	Total Class Hours
I.S.O. Company Training	2	5:00
<b>Total for Calderazzo, Vincent S</b>	<b>2</b>	<b>5:00</b>

### Davis-Whited, Crystal L

Class Category	Class Count	Total Class Hours
EMS Training	2	3:50
I.S.O. Company Training	3	11:00
I.S.O. Driver and Operator Training	1	3:00
<b>Total for Davis-Whited, Crystal L</b>	<b>6</b>	<b>17:50</b>

### Diaz, Tress A

Class Category	Class Count	Total Class Hours
I.S.O. Officer Training	1	1:00
<b>Total for Diaz, Tress A</b>	<b>1</b>	<b>1:00</b>

### Dorr, Patrick E

Class Category	Class Count	Total Class Hours
I.S.O. Company Training	2	5:00

This report lists a count of Classes completed by each Person, for each Class Category. Optionally filtered by Personnel and Passage or Failure. Time shown in Hours and Minutes. If "All Personnel" is selected, this report also includes non-agency Personnel. Only non-Archived Classes that have been Reviewed are included. This report pulls training hours from the Training Code Hours field on the Info Page.



<b>Total for Dorr, Patrick E</b>	<b>2</b>	<b>5:00</b>
----------------------------------	----------	-------------

**Embury, Andy G**

Class Category	Class Count	Total Class Hours
EMS Training	1	2:00
I.S.O. Company Training	1	1:00
<b>Total for Embury, Andy G</b>	<b>2</b>	<b>3:00</b>

**Evans, Harry A**

Class Category	Class Count	Total Class Hours
EMS Training	1	2:00
I.S.O. Company Training	1	1:00
<b>Total for Evans, Harry A</b>	<b>2</b>	<b>3:00</b>

**Fernandez III, Humberto**

Class Category	Class Count	Total Class Hours
EMS Training	3	6:50
I.S.O. Company Training	6	14:00
I.S.O. Driver and Operator Training	1	3:00
<b>Total for Fernandez III, Humberto</b>	<b>10</b>	<b>23:50</b>

**Fernandez, Sergio A**

Class Category	Class Count	Total Class Hours
EMS Training	2	5:00
I.S.O. Company Training	3	8:00
I.S.O. Driver and Operator Training	1	3:00
<b>Total for Fernandez, Sergio A</b>	<b>6</b>	<b>16:00</b>

**Frietze, Trevor R**

Class Category	Class Count	Total Class Hours
I.S.O. Company Training	2	7:00
<b>Total for Frietze, Trevor R</b>	<b>2</b>	<b>7:00</b>

**Garcia, Gilbert M**

Class Category	Class Count	Total Class Hours
I.S.O. Officer Training	1	1:00
<b>Total for Garcia, Gilbert M</b>	<b>1</b>	<b>1:00</b>

**Gaytan, Melina A**

Class Category	Class Count	Total Class Hours
I.S.O. Company Training	2	5:00
<b>Total for Gaytan, Melina A</b>	<b>2</b>	<b>5:00</b>

**Hoban, Kevin M**

Class Category	Class Count	Total Class Hours
EMS Training	1	2:00
I.S.O. Company Training	3	9:00
I.S.O. Driver and Operator Training	1	6:00
I.S.O. Officer Training	1	1:00
<b>Total for Hoban, Kevin M</b>	<b>6</b>	<b>18:00</b>

This report lists a count of Classes completed by each Person, for each Class Category. Optionally filtered by Personnel and Passage or Failure. Time shown in Hours and Minutes. If "All Personnel" is selected, this report also includes non-agency Personnel. Only non-Archived Classes that have been Reviewed are included. This report pulls training hours from the Training Code Hours field on the Info Page.

**Klebansky, George A**

Class Category	Class Count	Total Class Hours
EMS Training	1	2:00
I.S.O. Company Training	3	10:00
I.S.O. Driver and Operator Training	2	4:00
<b>Total for Klebansky, George A</b>	<b>6</b>	<b>16:00</b>

**Linares-Chacon, Sebastian**

Class Category	Class Count	Total Class Hours
I.S.O. Company Training	2	5:00
<b>Total for Linares-Chacon, Sebastian</b>	<b>2</b>	<b>5:00</b>

**Lucero, Sergio B**

Class Category	Class Count	Total Class Hours
EMS Training	1	2:00
I.S.O. Company Training	2	8:00
I.S.O. Driver and Operator Training	1	3:00
<b>Total for Lucero, Sergio B</b>	<b>4</b>	<b>13:00</b>

**Madson, Ed**

Class Category	Class Count	Total Class Hours
I.S.O. Officer Training	1	1:00
<b>Total for Madson, Ed</b>	<b>1</b>	<b>1:00</b>

**Manriquez, Humberto**

Class Category	Class Count	Total Class Hours
EMS Training	1	1:00
<b>Total for Manriquez, Humberto</b>	<b>1</b>	<b>1:00</b>

**Martinez, William A**

Class Category	Class Count	Total Class Hours
I.S.O. Company Training	3	14:00
I.S.O. Driver and Operator Training	1	3:00
<b>Total for Martinez, William A</b>	<b>4</b>	<b>17:00</b>

**Mendez, Sergio M**

Class Category	Class Count	Total Class Hours
I.S.O. Company Training	2	8:00
I.S.O. Driver and Operator Training	1	3:00
<b>Total for Mendez, Sergio M</b>	<b>3</b>	<b>11:00</b>

**Nanez, Ryan**

Class Category	Class Count	Total Class Hours
I.S.O. Officer Training	1	1:00
<b>Total for Nanez, Ryan</b>	<b>1</b>	<b>1:00</b>

**Ortiz, Yvonne**

Class Category	Class Count	Total Class Hours
EMS Training	1	2:00
I.S.O. Company Training	6	13:00

This report lists a count of Classes completed by each Person, for each Class Category. Optionally filtered by Personnel and Passage or Failure. Time shown in Hours and Minutes. If "All Personnel" is selected, this report also includes non-agency Personnel. Only non-Archived Classes that have been Reviewed are included. This report pulls training hours from the Training Code Hours field on the Info Page.

I.S.O. Driver and Operator Training	1	3:00
<b>Total for Ortiz, Yvonne</b>	<b>8</b>	<b>18:00</b>

**Rogers, Travis A**

Class Category	Class Count	Total Class Hours
EMS Training	1	2:00
I.S.O. Company Training	3	11:00
I.S.O. Driver and Operator Training	1	3:00
<b>Total for Rogers, Travis A</b>	<b>5</b>	<b>16:00</b>

**Salas, Enrique**

Class Category	Class Count	Total Class Hours
I.S.O. Officer Training	1	1:00
<b>Total for Salas, Enrique</b>	<b>1</b>	<b>1:00</b>

**Sanchez, Xavier**

Class Category	Class Count	Total Class Hours
EMS Training	2	4:50
I.S.O. Company Training	4	12:00
I.S.O. Driver and Operator Training	1	3:00
<b>Total for Sanchez, Xavier</b>	<b>7</b>	<b>19:50</b>

**Thunhorst, Ines C**

Class Category	Class Count	Total Class Hours
EMS Training	1	2:00
I.S.O. Company Training	2	4:00
I.S.O. Driver and Operator Training	1	1:00
<b>Total for Thunhorst, Ines C</b>	<b>4</b>	<b>7:00</b>

**Whited, Gregory E**

Class Category	Class Count	Total Class Hours
EMS Training	2	3:50
I.S.O. Company Training	3	11:00
I.S.O. Driver and Operator Training	1	3:00
<b>Total for Whited, Gregory E</b>	<b>6</b>	<b>17:50</b>

**Zapien, Jasha C**

Class Category	Class Count	Total Class Hours
EMS Training	1	2:00
I.S.O. Company Training	7	15:00
I.S.O. Driver and Operator Training	1	3:00
<b>Total for Zapien, Jasha C</b>	<b>9</b>	<b>20:00</b>

This report lists a count of Classes completed by each Person, for each Class Category. Optionally filtered by Personnel and Passage or Failure. Time shown in Hours and Minutes. If "All Personnel" is selected, this report also includes non-agency Personnel. Only non-Archived Classes that have been Reviewed are included. This report pulls training hours from the Training Code Hours field on the Info Page.

# Mesilla Fire Department

Mesilla, NM

This report was generated on 4/4/2022 11:43:42 AM



## Total Hours by Volunteers for March 2022

Pay Grades: All Pay Grades | Start Date: 03/01/2022 | End Date: 03/31/2022

PERSONNEL	INCIDENT TIME	TRAINING TIME	EVENT TIME	TOTAL TIME
Aguilar, Alexander J	9:33	3:00	6:00	18:33
Arguello, Katrina M	11:45	11:00	6:00	28:45
Brown, Tyler S	32:07	24:50	61:30	118:27
Calderazzo, Vincent S	4:00	5:00	18:00	27:00
Davis-Whited, Crystal L	37:05	17:50	13:15	68:10
Dorr, Patrick E	4:00	5:00	19:00	28:00
Dove, Michael S	1:00	0:00	4:30	5:30
Embury, Andy G	34:09	3:00	4:00	41:09
Evans, Harry A	11:15	3:00	18:00	32:15
Fernandez III, Humberto	23:00	23:50	69:00	115:50
Fernandez, Sergio A	2:15	18:00	19:00	39:15
Franco, Gabriel Z	1:45	0:00	16:00	17:45
Frietze, Trevor R	3:23	7:00	14:30	24:53
Gaytan, Melina A	3:30	5:00	13:00	21:30
Klebansky, George A	60:31	18:00	10:30	89:01
Linares-Chacon, Sebastian	4:00	5:00	62:30	71:30
Lucero, Sergio B	11:30	13:00	1:00	25:30
Manriquez, Humberto	2:00	1:00	28:00	31:00
Martinez, William A	11:00	17:00	0:00	28:00
Mendez, Sergio M	13:15	11:00	2:30	26:45
Ortiz, Yvonne	7:00	23:00	9:00	39:00
Rodriguez, Gabriel	0:15	0:00	22:00	22:15
Rogers, Travis A	12:53	16:00	27:57	56:50
Sanchez, Xavier	22:18	19:50	66:30	108:38
Thunhorst, Dylan P	3:40	0:00	18:45	22:25
Thunhorst, Ines C	8:06	7:00	35:45	50:51
Whited, Gregory E	43:20	17:50	18:30	79:40
Zapien, Jasha C	31:21	20:00	80:30	131:51
			<b>TOTAL</b>	<b>1341:48:00</b>

# Mesilla Fire Department

Mesilla, NM

This report was generated on 4/4/2022 12:13:41 PM



## Response Activity Report

Start Date: 03/01/2022 | End Date: 03/31/2022

INCIDENT #	DATE	APPARATUS ID	ALARM TIME	ARRIVE TIME	RESPONSE TIME	ADDRESS
<b>111 - Building fire</b>						
2022-00144	03/27/2022	SQ32	13:35:35	14:20:00	00:44:25	5810 Mariachi PL
Subtotal Count: 1		111 - Building fire   Average Response Time: 00:44:25				
<b>132 - Road freight or transport vehicle fire</b>						
2022-00136	03/25/2022	Bat32	09:52:09	10:15:52	00:23:43	14535 ROBERT LARSON BLVD
Subtotal Count: 1		132 - Road freight or transport vehicle fire   Average Response Time: 00:23:43				
<b>136 - Self-propelled motor home or recreational vehicle</b>						
2022-00116	03/13/2022	Bat32	03:47:55	04:12:00	00:24:05	4801 S MAIN ST
2022-00116	03/13/2022	E31	03:47:55	04:12:00	00:24:05	4801 S MAIN ST
Subtotal Count: 2		136 - Self-propelled motor home or recreational vehicle   Average Response Time: 00:24:05				
<b>142 - Brush or brush-and-grass mixture fire</b>						
2022-00095	03/01/2022	Bat32	13:03:54	17:54:12	04:50:18	23420 HIGHWAY 185
2022-00095	03/01/2022	BR31	13:03:54	17:49:46	04:45:52	23420 HIGHWAY 185
2022-00106	03/08/2022	Bat31	10:46:45	11:18:38	00:31:53	3790 TIERRA RD
2022-00106	03/08/2022	Bat32	10:46:45	11:40:56	00:54:11	3790 TIERRA RD
2022-00106	03/08/2022	BR33	10:46:45	11:27:26	00:40:41	3790 TIERRA RD
2022-00126	03/21/2022	Bat32	16:08:51	17:57:04	01:48:13	347 OLD HIGHWAY 292
2022-00126	03/21/2022	BR31	16:08:51	18:01:39	01:52:48	347 OLD HIGHWAY 292
2022-00139	03/26/2022	Bat32	07:56:38	08:10:20	00:13:42	2900 BOWMAN ST
2022-00139	03/26/2022	BR31	07:56:38	08:10:23	00:13:45	2900 BOWMAN ST
2022-00140	03/26/2022	Bat32	10:18:42	10:34:54	00:16:12	604 CONWAY AVE
2022-00140	03/26/2022	BR31	10:18:42	10:34:33	00:15:51	604 CONWAY AVE
2022-00141	03/26/2022	BR31	13:28:09	13:36:22	00:08:13	604 CONWAY AVE
Subtotal Count: 12		142 - Brush or brush-and-grass mixture fire   Average Response Time: 01:22:38				
<b>251 - Excessive heat, scorch burns with no ignition</b>						
2022-00101	03/05/2022	Bat31	09:51:56	09:56:52	00:04:56	2961 MCDOWELL RD
2022-00101	03/05/2022	E32	09:51:56	10:08:05	00:16:09	2961 MCDOWELL RD
Subtotal Count: 2		251 - Excessive heat, scorch burns with no ignition   Average Response Time: 00:10:32				
<b>311 - Medical assist, assist EMS crew</b>						
2022-00098	03/03/2022	Bat31	21:34:10	21:50:54	00:16:44	2417 CALLE DE PARIAN
2022-00098	03/03/2022	Bat32	21:34:10	21:56:00	00:21:50	2417 CALLE DE PARIAN
2022-00105	03/06/2022	Bat31	19:31:22	19:40:18	00:08:56	2170 CALLE DE ARROYO
2022-00105	03/06/2022	Bat32	19:31:22	19:38:56	00:07:34	2170 CALLE DE ARROYO
2022-00114	03/09/2022	Bat31	20:59:24	21:16:43	00:17:19	1875 MESILLA HILLS DR
2022-00114	03/09/2022	SQ32	20:59:24	21:17:09	00:17:45	1875 MESILLA HILLS DR
2022-00146	03/28/2022	Bat31	16:01:52	16:28:05	00:26:13	5243 APACHE TRL

Calls by Incident Type. Does not include calls where there was no response.



emergencyreporting.com  
Doc Id: 1196  
Page # 1 of 4

2022-00151	03/29/2022	SQ32	16:45:27	16:58:45	00:13:18	1680 CALLE DE ALVAREZ
<b>Subtotal Count: 8</b>		<b>311 - Medical assist, assist EMS crew   Average Response Time: 00:16:12</b>				
<b>320 - Emergency medical service, other</b>						
2022-00125	03/20/2022	SQ32	12:44:06	13:03:00	00:18:54	12000 STERN DR
<b>Subtotal Count: 1</b>		<b>320 - Emergency medical service, other   Average Response Time: 00:18:54</b>				
<b>321 - EMS call, excluding vehicle accident with injury</b>						
2022-00092	03/01/2022	Bat31	10:40:17	10:44:35	00:04:18	2670 CALLE DE PARIAN
2022-00092	03/01/2022	Bat32	10:40:17	10:44:35	00:04:18	2670 CALLE DE PARIAN
2022-00094	03/01/2022	Bat31	12:38:38	12:46:18	00:07:40	1300 W UNIVERSITY AVE
2022-00099	03/03/2022	Bat31	23:41:11	23:44:43	00:03:32	2171 CALLE DE PARIAN
2022-00107	03/08/2022	Bat32	23:28:30	23:42:49	00:14:19	1306 W UNIVERSITY AVE
2022-00107	03/08/2022	E31	23:28:30	23:42:09	00:13:39	1306 W UNIVERSITY AVE
2022-00108	03/09/2022	Bat32	01:18:05	01:28:42	00:10:37	2481 CALLE DE CURA
2022-00108	03/09/2022	E32	01:18:05	01:26:08	00:08:03	2481 CALLE DE CURA
2022-00113	03/09/2022	Bat31	17:19:14	17:26:55	00:07:41	2355 CALLE DE GUADALUPE
2022-00113	03/09/2022	SQ32	17:19:14	17:26:00	00:06:46	2355 CALLE DE GUADALUPE
2022-00118	03/13/2022	Bat31	13:05:09	13:11:26	00:06:17	2670 CALLE DE PARIAN
2022-00119	03/14/2022	Bat31	18:46:34	18:53:35	00:07:01	2260 CALLE DE SANTIAGO
2022-00120	03/15/2022	Bat31	20:41:07	20:53:19	00:12:12	1395 SNOW RD
2022-00120	03/15/2022	Bat32	20:41:07	20:53:13	00:12:06	1395 SNOW RD
2022-00121	03/16/2022	Bat31	20:47:24	20:57:27	00:10:03	1420 W UNION AVE
2022-00121	03/16/2022	Bat32	20:47:24	20:57:29	00:10:05	1420 W UNION AVE
2022-00121	03/16/2022	E32	20:47:24	20:56:32	00:09:08	1420 W UNION AVE
2022-00121	03/16/2022	SQ32	20:47:24	20:57:35	00:10:11	1420 W UNION AVE
2022-00122	03/19/2022	Bat31	11:52:39	12:11:33	00:18:54	2355 CALLE DE GUADALUPE
2022-00122	03/19/2022	SQ32	11:52:39	11:58:32	00:05:53	2355 CALLE DE GUADALUPE
2022-00123	03/19/2022	SQ32	12:32:24	12:32:24	00:00:00	12000 STERN DR
2022-00124	03/19/2022	Bat31	20:19:20	20:38:42	00:19:22	3916 W PICACHO AVE
2022-00124	03/19/2022	Bat32	20:19:20	20:44:00	00:24:40	3916 W PICACHO AVE
2022-00124	03/19/2022	SQ32	20:19:20	20:41:28	00:22:08	3916 W PICACHO AVE
2022-00127	03/21/2022	Bat31	23:20:06	23:50:41	00:30:35	323 LAS FLORES CIR
2022-00127	03/21/2022	Bat32	23:20:06	23:41:50	00:21:44	323 LAS FLORES CIR
2022-00127	03/21/2022	BR31	23:20:06	23:42:06	00:22:00	323 LAS FLORES CIR
2022-00128	03/22/2022	Bat31	01:33:11	01:44:29	00:11:18	2170 CALLE DEL ARROYO
2022-00128	03/22/2022	Bat32	01:33:11	01:42:37	00:09:26	2170 CALLE DEL ARROYO
2022-00128	03/22/2022	SQ32	01:33:11	01:39:30	00:06:19	2170 CALLE DEL ARROYO
2022-00129	03/22/2022	Bat31	05:46:42	06:17:43	00:31:01	713 SNOW RD
2022-00129	03/22/2022	SQ32	05:46:42	06:20:47	00:34:05	713 SNOW RD
2022-00130	03/22/2022	Bat32	12:22:18	12:29:59	00:07:41	300 CAPRI ARC
2022-00132	03/23/2022	Bat31	15:33:37	16:01:55	00:28:18	4105 SOUTHWIND RD
2022-00132	03/23/2022	E31	15:33:37	15:50:02	00:16:25	4105 SOUTHWIND RD
2022-00135	03/25/2022	Bat31	05:22:25	05:38:31	00:16:06	2452 CALLE DE CURA
2022-00135	03/25/2022	Bat32	05:22:25	05:33:59	00:11:34	2452 CALLE DE CURA
2022-00137	03/25/2022	Bat31	20:58:33	21:10:27	00:11:54	3120 CALLE DE GUADALUPE
2022-00137	03/25/2022	Bat32	20:58:33	21:07:52	00:09:19	3120 CALLE DE GUADALUPE
2022-00137	03/25/2022	BR31	20:58:33	21:08:10	00:09:37	3120 CALLE DE GUADALUPE

Calls by Incident Type. Does not include calls where there was no response.



2022-00137	03/25/2022	SQ32	20:58:33	21:16:19	00:17:46	3120 CALLE DE GUADALUPE
2022-00142	03/26/2022	BR31	14:14:11	14:37:29	00:23:18	2446 SNOW RD
2022-00142	03/26/2022	SQ32	14:14:11	14:37:49	00:23:38	2446 SNOW RD
2022-00143	03/27/2022	Bat31	09:18:39	09:36:38	00:17:59	267 WHITE OPAL RD
2022-00143	03/27/2022	Bat32	09:18:39	09:35:26	00:16:47	267 WHITE OPAL RD
2022-00145	03/27/2022	Bat31	15:05:55	15:19:30	00:13:35	713 SNOW RD
2022-00152	03/31/2022	Bat31	21:44:20	21:59:35	00:15:15	2170 CALLE DE PARIAN
2022-00152	03/31/2022	Bat32	21:44:20	21:50:58	00:06:38	2170 CALLE DE PARIAN
2022-00152	03/31/2022	BR31	21:44:20	21:50:58	00:06:38	2170 CALLE DE PARIAN
<b>Subtotal Count: 49                      321 - EMS call, excluding vehicle accident with injury   Average Response Time: 00:13:37</b>						
<b>322 - Motor vehicle accident with injuries</b>						
2022-00109	03/09/2022	Bat31	09:20:41	09:36:03	00:15:22	AVENIDA DE MESILLA
2022-00109	03/09/2022	Bat32	09:20:41	09:36:03	00:15:22	AVENIDA DE MESILLA
2022-00109	03/09/2022	SQ32	09:20:41	09:40:59	00:20:18	AVENIDA DE MESILLA
2022-00112	03/09/2022	Bat31	15:10:58	15:15:26	00:04:28	2231 AVENIDA DE MESILLA
2022-00112	03/09/2022	SQ32	15:10:58	15:17:00	00:06:02	2231 AVENIDA DE MESILLA
2022-00131	03/23/2022	Bat32	14:49:22	15:29:18	00:39:56	116 INTERSTATE 10
2022-00147	03/28/2022	Bat32	19:43:09	20:01:23	00:18:14	22500 S HIGHWAY 28
2022-00147	03/28/2022	E31	19:43:09	20:07:06	00:23:57	22500 S HIGHWAY 28
2022-00149	03/29/2022	Bat31	16:09:47	16:13:59	00:04:12	3036 AVENIDA DE MESILLA
2022-00149	03/29/2022	BR31	16:09:47	16:20:01	00:10:14	3036 AVENIDA DE MESILLA
<b>Subtotal Count: 10                      322 - Motor vehicle accident with injuries   Average Response Time: 00:15:48</b>						
<b>381 - Rescue or EMS standby</b>						
2022-00100	03/05/2022	Bat31	08:02:49	08:02:50	00:00:01	1300 W UNIVERSITY AVE
2022-00100	03/05/2022	Bat32	08:02:49	08:02:50	00:00:01	1300 W UNIVERSITY AVE
2022-00102	03/05/2022	SQ32	10:09:53	10:10:37	00:00:44	12000 STERN DR
2022-00104	03/06/2022	SQ32	12:10:10	12:10:38	00:00:28	12000 STERN DR
2022-00115	03/12/2022	SQ32	12:37:01	12:37:02	00:00:01	12000 STERN DR
2022-00117	03/13/2022	SQ32	12:32:58	12:34:07	00:01:09	12000 STERN DR
<b>Subtotal Count: 6                      381 - Rescue or EMS standby   Average Response Time: 00:00:24</b>						
<b>412 - Gas leak (natural gas or LPG)</b>						
2022-00096	03/02/2022	Bat31	16:02:45	16:15:01	00:12:16	1363 SNOW RD
2022-00096	03/02/2022	E32	16:02:45	16:21:14	00:18:29	1363 SNOW RD
2022-00097	03/03/2022	Bat31	09:54:04	10:22:17	00:28:13	2839 CALLE DEL SUR
2022-00097	03/03/2022	Bat32	09:54:04	10:26:18	00:32:14	2839 CALLE DEL SUR
2022-00097	03/03/2022	E32	09:54:04	10:32:28	00:38:24	2839 CALLE DEL SUR
<b>Subtotal Count: 5                      412 - Gas leak (natural gas or LPG)   Average Response Time: 00:25:55</b>						
<b>511 - Lock-out</b>						
2022-00110	03/09/2022	Bat31	10:03:01	10:04:12	00:01:11	2011 AVENIDA DE MESILLA
2022-00110	03/09/2022	SQ32	10:03:01	10:07:00	00:03:59	2011 AVENIDA DE MESILLA
<b>Subtotal Count: 2                      511 - Lock-out   Average Response Time: 00:02:35</b>						
<b>522 - Water or steam leak</b>						
2022-00134	03/24/2022	Bat31	17:38:30	17:41:24	00:02:54	2475 CALLE DE PARIAN
<b>Subtotal Count: 1                      522 - Water or steam leak   Average Response Time: 00:02:54</b>						

Calls by Incident Type. Does not include calls where there was no response.



551 - Assist police or other governmental agency						
2022-00093	03/01/2022	E32	12:07:00	12:29:37	00:22:37	2106 CALLE DEL NORTE
Subtotal Count: 1                      551 - Assist police or other governmental agency   Average Response Time: 00:22:37						
561 - Unauthorized burning						
2022-00148	03/29/2022	Bat31	09:10:50	09:10:50	00:00:00	3044 CAFFEY LN
Subtotal Count: 1                      561 - Unauthorized burning   Average Response Time: 00:00:00						
622 - No incident found on arrival at dispatch address						
2022-00103	03/05/2022	Bat32	23:29:35	23:48:58	00:19:23	HIGHWAY 478
2022-00111	03/09/2022	Bat31	13:49:18	13:54:22	00:05:04	1983 CALLE DEL NORTE
2022-00111	03/09/2022	SQ32	13:49:18	13:54:29	00:05:11	1983 CALLE DEL NORTE
Subtotal Count: 3                      622 - No incident found on arrival at dispatch address   Average Response Time: 00:09:52						
631 - Authorized controlled burning						
2022-00138	03/26/2022	Bat31	06:12:30	06:50:00	00:37:30	5000 CALLE DEL NORTE
2022-00138	03/26/2022	Bat32	06:12:30	06:50:00	00:37:30	5000 CALLE DEL NORTE
2022-00138	03/26/2022	BR31	06:12:30	06:50:00	00:37:30	5000 CALLE DEL NORTE
2022-00138	03/26/2022	BR33	06:12:30	06:50:00	00:37:30	5000 CALLE DEL NORTE
2022-00138	03/26/2022	E31	06:12:30	06:50:00	00:37:30	5000 CALLE DEL NORTE
Subtotal Count: 5                      631 - Authorized controlled burning   Average Response Time: 00:37:30						
813 - Wind storm, tornado/hurricane assessment						
2022-00150	03/29/2022	Bat31	16:35:24	16:41:06	00:05:42	W UNIVERSITY AVE
2022-00150	03/29/2022	Bat32	16:35:24	16:43:00	00:07:36	W UNIVERSITY AVE
2022-00150	03/29/2022	BR31	16:35:24	16:44:00	00:08:36	W UNIVERSITY AVE
Subtotal Count: 3                      813 - Wind storm, tornado/hurricane assessment   Average Response Time: 00:07:18						
<b>Grand Total: 113</b>			<b>Average Response Time for All Incident Types: 00:22:10</b>			

Calls by Incident Type. Does not include calls where there was no response.





# MESILLA MARSHAL DEPARTMENT

P.O. BOX 10 MESILLA, NM 88046 PHONE 575-526-4138 FAX 575-652-3776

To: Honorable Mayor and Mesilla Board of Trustees

This is the Monthly Report for March 2022, for the Mesilla Marshal's Department:

911 hang ups	12	Illegally parked vehicle	1
Agency assist	18	Information report	16
ACO calls	23	Lost property	1
Auto burglary	1	Loud party	1
Auto theft	2	Medical alarm	1
Behavioral	2	Missing person	1
Burglary	4	Motor Vehicle Crashes	17
Burglary alarm	4	Obstruction	3
Child abuse	2	Out with subject	1
Civil	3	Overdose	2
Codes	10	Phone call	4
CPR	1	Prisoner Transport	8
Disturbances	19	Reckless driver	4
Foot patrol	2	Sex offenses	1
Found property	1	Shoplifting	1
Forgery/fraud	2	Shots fired	1
Frequent patrol	10	Supplement	22

Suspicious activity	10
Theft	2
Threats	1
Traffic complaint	1
Traffic stops	77

Trespassing	3
Vandalism/graffiti	1
Warrant service	1
<u>Welfare check</u>	<u>6</u>
Total # of calls for service	314

Thank you,

Enrique Salas,  
Marshal



# TOWN OF MESILLA

Public Works Department  
P.O. Box 10, Mesilla, New Mexico 88046  
Office: (575) 524-3262  
Fax: (575) 541-6327

## MEMORANDUM

Date: April 1, 2022  
TO: Mayor Barraza and Board of Trustees  
FROM: Rodney J. McGillivray, Public Works Director   
RE: **Public Works Division Activity Report – March 2022**

### **On-going maintenance, custodial and operations:**

On-call/standby for emergency repairs or assistance  
Meter reading continues  
Monitoring of lift stations and review of reporting  
Monthly water sampling and reporting is up-to-date  
Monitoring of water tank, wells, and pumps  
New water services and water shut-offs (ownership change/nonpayment)  
Utility location services  
Grounds maintenance on-going  
Custodial responsibilities on-going  
Valve exercise program continues  
Vehicle maintenance on-going

### **Miscellaneous items/work orders/accomplishments:**

Covid disinfectant fogging  
Replaced flags at Vets Park and Plaza  
Pump failure, repairs and cleaning at sewer lift station  
Pothole repairs on Piasano  
Tree trimming on Calle de los Huertos  
Installed new meter at Plaza  
Training with Water Meters of NM  
Plaza and Vets flower rejuvenation  
Began Town wide weed eradication  
Repaired lighting in Town Hall

Began painting street light poles  
Repairs to fire hydrant at PSB  
Completed hydrant repairs on Boutz  
Fountain pump replacement  
Painting men's public restroom  
Replaced urinal in men's public restroom  
Tree trimming at traffic light Vets Park  
Trail Maintenance  
Continued hydrant inspection  
Emergency tree removal University Ave.  
Plaza brick repairs  
Sewer repairs at Community Center  
Flood irrigation of parks

**Project update:**

**Calle del Norte Trail Phase II** – Request for an extension of time submitted. Project bidding first week in April. The recommendation to bid and notice to proceed is anticipated to be brought before the BOT on April 25, 2022.

**SCADA** – Design is underway. Electrical engineer performed a site visit on 3/25/2022. Anticipate design to be at 95% mid-May.

**Mesilla Water System Booster Replacement** – BLM permit process is nearing completion. Once we receive BLM approval NMED will begin their review. Project anticipated to bid in June 2022.

**Mesilla Streetlight Improvements** – Purchase order to CES for Lynco Electric is complete. Lynco Electric anticipates having the electrical engineering complete mid-April. Light fixtures have been ordered. The Town is self-performing the re-painting of the street light poles.

**Calle de Picacho Drainage:** Purchase order for design services is complete. MC to compile design schedule.

**Calle de Picacho Roadway Improvements:** Purchase order for design services is complete. MC to compile design schedule.

**Plaza Sidewalk Refurbishment** – Purchase order for design services is complete. Design kick off meeting held on 3/30/2022. Design is underway. MC to compile design schedule.

**Colonias - University Waterline Improvements** – Project design kick-off meeting with BHI is scheduled for 4/5/2022. Anticipate design to be 60% complete by end of May.